

Valor® P2 200A

February 2024

1/2

Cement Board & Wall Finishing

Planning Wall Finish

Non-Combustible Materials Specifications

Non-combustible materials will not ignite and burn. Such materials are those consisting entirely of steel, iron, brick, tile, concrete, slate, glass or plasters, or any combination thereof.

Materials that are reported as passing ASTM E 136, Standard Test Method for Behavior of Materials in a Vertical Tube Furnace at 750 °C shall be considered non-combustible materials.

Combustible Materials Specifications

Materials made of or surfaced with wood, compressed paper, plant fibers, plastics, or other material that can ignite and burn, whether flame proofed or not, or plastered or unplastered shall be considered combustible materials.

Non-combustible cement board—ZC applications

With most front trims, the 200 fireplace installed in a zero clearance application will require a 1/2" [13 mm] thick non-combustible cement board or equivalent, to be used as a wall surface immediately above the unit—see illustration for minimum coverage.

Extending the cement board well beyond the minimum shown will help avoid cracking due to differential expansion of materials.

Pre-drill cement board with oversized holes and do not over-tighten screws to avoid cracking due to heat expansion.

Standard gypsum wall board may be used beyond the perimeter of the cement board although it is preferable not to change materials to help avoid cracking.

Finishing around trims

Additional non-combustible material such as tile and others may be applied over top of the wall surface or you may choose to leave it finished clean with no tile.

Be aware that a front and backing plate are always required and that the wall finish thickness must be taken into account for all installations other than the 230CIK—Clean Installation Kit.

Non-combustible board required thickness:
1/2 inch [13 mm]

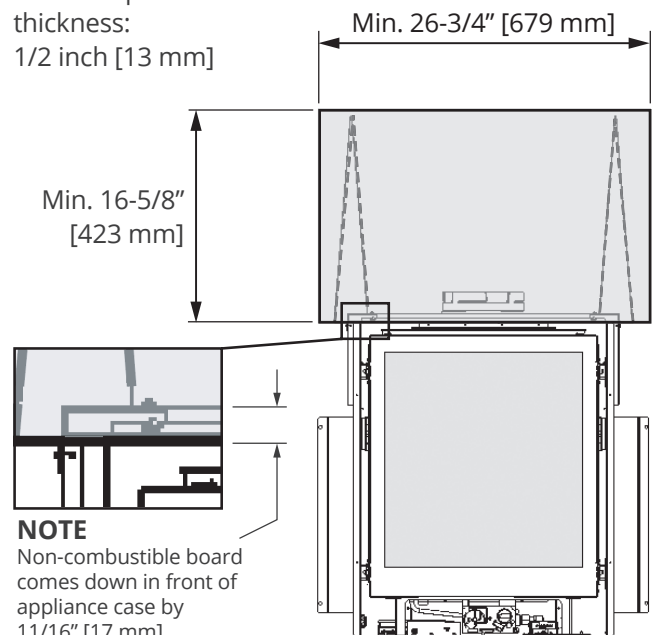

Minimum non-combustible board dimensions

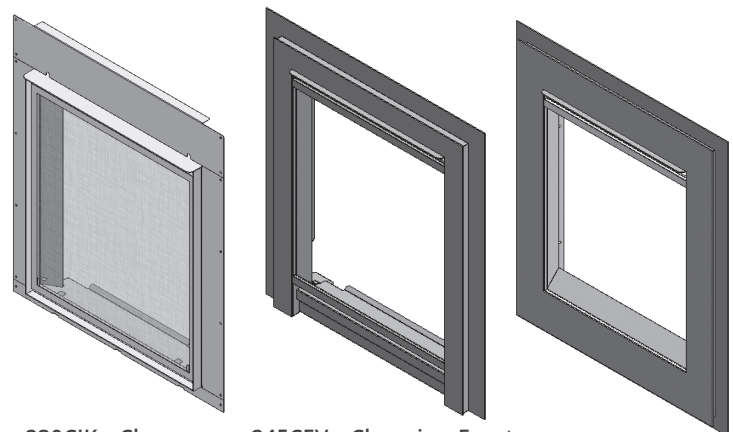

230CIK—Clean Installation Kit

245CFV—Clearview Front shown with 235BPB1—Backing Plate

246LF—4-sided Ledgeview

Cement Board & Wall Finishing

The 230CIK installs at framing stage and must be installed at the same time as the appliance. Wall finishes cover the kit's panels and butt up to its fireplace opening frame.

The 245CFV + 235BPB1 or 235BPB2, and 246LF trims install after wall finish is applied. The perimeter of backing plates overlap wall finish; therefore thickness of any wall finish materials must be taken into consideration. Backing plates have enough adjustability to allow up to 3/4" thick non-combustible material applied over top of 1/2" thick non-combustible board.

Avoiding Cracking Wall Finishes

We recommend installing the optional HeatShift System to reduce the wall temperatures and minimize the possibility of cracking wall finishes—see HeatShift in Installation Manual.

If a clean finish with no tile, etc. is desired, joints in the non-combustible board and the transition to gypsum board will require special attention if future cracking is to be controlled.

Shrinkage and differential movement of the framing and non-combustible wall board can transmit cracking through to tiles, etc.

Be aware that temperatures on the non-combustible wall surface above the appliance can exceed 185°F.

Below are some tips on how to best avoid any cracking:

- Allow materials to dry thoroughly before finishing the wall. Cement board has the ability to absorb up to 30 percent of its weight in water and may shrink as much as 1/8" over a 48" length when drying from a saturated condition. Running the fireplace for an extended period before final finishing will help drive out moisture.
- Always pre-drill screw holes through cement board and use screws with self-milling head.
- Always use mesh tape over joints.
- Always stagger joints in wall board.
- Behind joints, double up studs or use studs "on the flat" to add extra support to the joint. Adhesive on the backside of wall board behind any joints can help control differential movement.
- Use multiple, thinner coats of joint compound and allow to dry thoroughly between coats.
- Ensure framing materials are dry.
- After finishing the wall, introduce heat gradually to slowly dry any excess moisture rather than drying too fast.
- Avoid notching cement board or tiles around corners of window opening and instead provide a joint that intersects the corner.
- Avoid using large, one-piece slab of material with a cut-out in the middle as a surround for the fireplace. Expansion above the opening will cause cracking at inside corners. Provide a joint that intersects the inside corner to avoid cracking.

