

valor[®] Portrait



Direct Vent Gas Fireplace
530IN (natural gas) & 530IP (propane gas)

DANGER



**HOT GLASS WILL
CAUSE BURNS.**

**DO NOT TOUCH GLASS
UNTIL COOLED.**

**NEVER ALLOW CHILDREN
TO TOUCH GLASS.**

A barrier designed to reduce the risk of burns from the hot viewing glass is provided with this appliance and must be installed for the protection of children and other at-risk individuals.

**Please read this manual
BEFORE installing and
operating this appliance.**

INSTALLER: Leave this manual with the appliance.
CONSUMER: Retain this manual for future reference.

This manual contains instructions to install the **ENGINE ONLY**. A front kit is **REQUIRED** to complete the installation. A barrier screen is provided with the front. **Refer to the manual supplied with the front for installation.**

⚠ WARNING
FIRE OR EXPLOSION HAZARD
Failure to follow safety warnings exactly could result in serious injury, death, or property damage.

- Do not store or use gasoline or other flammable vapors and liquids in the vicinity of this or any other appliance.
- **WHAT TO DO IF YOU SMELL GAS**
 - Do not try to light any appliance.
 - Do not touch any electrical switch; do not use any phone in your building.
 - Leave the building immediately.
 - Immediately call your gas supplier from a neighbor's phone. Follow the gas supplier's instructions.
 - If you cannot reach your gas supplier, call the fire department.
- Installation and service must be performed by a qualified installer, service agency or the gas supplier.

This appliance may be installed in an after-market permanently located, manufactured (mobile) home where not prohibited by local codes.

This appliance is only for use with the type of gas indicated on the rating plate. This appliance is not convertible for use with other gases, unless a certified kit is used.

This appliance is a domestic room-heating appliance. It must not be used for any other purposes such as drying clothes, etc.

This appliance is suitable for installation in a bedroom or bed sitting room.

Installer: Place model/serial number here.

Ce guide est disponible en français sur demande.

Table of Contents

FOR THE OWNER

Safety and Your Fireplace	3
Introduction	6
Locating Fireplace & Lighting Information Card	6
Operating Your Fireplace for the First Time.....	6
Operating Your Fireplace	7
Fireplace Control Devices	7
How to Turn Your Fireplace OFF (including pilot).....	7
How to Ensure Your Fireplace Cannot Be Turned ON Inadvertently	7
Using the Remote Control	8
Kits & Accessories	12
Lighting Instructions	13
Servicing & Maintenance	14
Servicing Your Fireplace.....	14
Annual Inspection	14
Cleaning Your Fireplace	15
Checking Pilot and Burner Flames	17
Replacing Batteries	18
Using Handset Wall Holder.....	18
Warranty	50

FOR THE QUALIFIED INSTALLER

Specifications	19
Dimensions, Clearance and Framing	20
Venting	20
Co-Axial Venting	22
Co-Linear Venting	29
Installation Planning	30
Installation	31
Unpack Appliance.....	31
Remove Window	31
Convert from Rear Outlet to Top Outlet (co-axial venting)	31
Prepare Vent Outlet.....	32
Connect Gas Supply.....	33
Install Ceramic Liners (Logs or Coals only).....	34
Install the 530LSK—Traditional Logs Set.....	35
Install the 530CSK—Coal Set	36
Install the 530RSK—Rock Set and Liners.....	37
Install the 530DWK—Driftwood Kit and Liners	39
Refit and Check Window	41
Install Battery Holder	42
Synchronize Remote Control.....	42
Check Operation.....	43
Set Aeration	43
Install Front, Trim and Barrier Screen.....	44
Install Remote Control Handset Wall Holder	44
Wiring Diagram	45
Approved Venting Components	46
Commonwealth of Massachusetts	48
Warranty	50
Replacement Parts	51

Warranty Card at the back of this manual.

Massachusetts: The piping and final gas connection must be performed by a licensed plumber or gas fitter in the State of Massachusetts. Also, see Carbon Monoxide Detector requirements on page 48.

**NATIONAL
FIREPLACE
INSTITUTE**



CERTIFIED
www.nficertified.org

We recommend that our gas hearth products be installed and serviced by professionals who are certified in the U.S. by the National Fireplace Institute® (NFI) as NFI Gas Specialists.

The information contained in this installation manual is believed to be correct at the time of printing. Miles Industries Ltd. reserves the right to change or modify any information or specifications without notice. Miles Industries Ltd. grants no warranty, implied or stated, for the installation or maintenance of your heater, and assumes no responsibility for any consequential damage(s).

**Designed and Manufactured by / for
Miles Industries Ltd.**

190–2255 Dollarton Highway, North Vancouver, BC, CANADA V7H 3B1

Tel. 604-984-3496 Fax 604-984-0246

www.valorfireplaces.com



SAFETY AND YOUR FIREPLACE

Read and understand all instructions carefully before starting the installation. **Failure to follow** these installation instructions may result in possible fire hazard and will void the warranty.

Prior to the first firing of the fireplace, read the Owner's information section of this manual.

Do not use this appliance if any part has been under water. Immediately, call a qualified service technician to inspect the unit and to replace any part of the control system and any gas control that has been under water.

This unit is not for use with solid fuel.

Installation and repair should be performed by a qualified service person. The appliance and venting system should be **inspected** before initial use and at least annually by a professional service person. More frequent cleaning may be required due to excessive lint from carpeting, bedding, etc. It is **imperative** that the unit's control compartment, burner, and circulating air passageways **be kept clean** to provide for adequate combustion and ventilation air.

Always keep the appliance clear and free from combustible materials, gasoline, and other flammable vapors and liquids.

Never obstruct the flow of combustion and ventilation air. Keep the front of the appliance **clear** of all obstacles and materials for servicing and proper operation.

This unit must be used with a vent system as described in this installation manual. **No other** vent system or components **may be used**.

This gas fireplace and vent assembly must be vented directly to the outside and must never be attached to a chimney serving a separate solid fuel burning appliance. Each gas appliance must use a separate vent system. Common vent systems are prohibited.

Inspect the external vent cap on a regular basis to make sure that no debris, plants, trees, shrubs are interfering with the air flow.

Turn off the gas before servicing this appliance. It is recommended that a qualified service technician perform an appliance check-up at the beginning of each heating season.



WARNING:

This product can potentially expose you to chemicals including Benzene which are known to the State of California to cause cancer and birth defects or other reproductive harm. **For more information go to www.P65Warnings.ca.gov**

Do not use this heater as a temporary source of heat during construction.

Due to the high temperature, the appliance should be **located** out of traffic areas and away from furniture and draperies.

Clothing or flammable material **should not be placed** on or near the appliance.

This appliance is a **domestic room-heating appliance**. It must not be used for any other purposes such as drying clothes, etc.

Do not place furniture or any other combustible household objects within 36" of the fireplace front.

Be careful not to put any decorating objects sensitive to heat to close above or around the fireplace as it gets very hot when operating.

The glass door assembly must be in place and sealed before the unit can be placed into safe operation.

Do not operate this appliance with the glass door removed, cracked, or broken. Replacement of the glass door should be performed by a licensed or qualified service person. Do not strike or slam the glass door.

The glass door assembly shall only be replaced as a complete unit, as supplied by the fireplace manufacturer. No substitute material may be used.

Do not use abrasive cleaners on the glass door assembly. Do not attempt to clean the glass door when it is hot.

A barrier designed to reduce the risk of burns from the hot viewing glass is provided with this appliance and **shall be installed for the protection of children and other at-risk individuals.**

If the barrier becomes damaged, the barrier shall be replaced with the manufacturer's barrier for this appliance.

Any safety screen, guard or barrier removed for servicing the appliance, must be replaced prior to operating the appliance.

Children and adults should be alerted to the hazards of high surface temperature and should stay away to avoid burns or clothing ignition.

Young children should be carefully supervised when they are in the same room as the appliance. Toddlers, young children and others may be susceptible to accidental contact burns. A physical barrier is recommended if there are at-risk individuals in the house. To restrict access to a fireplace or stove, install an adjustable safety gate to keep toddlers, young children and other at-risk individuals out of the room and away from hot surfaces.



Safety and Your Fireplace

Read and carefully follow all safety warnings and operating instructions contained in your owner's manual

Replacement manuals are available by contacting the Valor Service Department at 1-800-468-2567 or visit www.valorfireplaces.com.

FOLLOW THESE IMPORTANT CHILD SAFETY PRECAUTIONS AND RECOMMENDATIONS

Parts of your Valor Fireplace become extremely hot while in operation.

The glass viewing window temperature can exceed 500 F at full capacity.

Momentary contact with a hot glass surface can cause a severe burn, even if the fireplace is operating at reduced heating capacity.

The glass window will remain hot for an extended period of time after the fireplace has been turned off. Ensure that children are prevented from touching the fireplace during the cool down period.

Toddlers and Young Children must be closely supervised at all times when they are in the same room as the operating fireplace. They lack full awareness of danger and rely on your protection. Toddlers, in particular, do not have the motor skills and response reflexes to withdraw in the event of accidental contact with a hot surface.

A physical barrier is strongly recommended if there are young children, or at-risk individuals in the house. Install an approved after-market safety gate to keep toddlers, young children and



other at-risk individuals a safe distance from the fireplace.

Keep the remote control handset out of reach of children at all times. A wall mount storage holster is provided with your remote control handset.

Ensure that the fireplace, including the pilot light, is completely turned off when children are present and close supervision and safety barriers are not available—see page 7 of this manual.

If the fireplace is not going to be used for the summer or any extended period of time, remove the batteries from the remote control handset and remote battery holder. It is recommended that batteries are replaced annually in any event—see page 18.



SAFETY AND YOUR FIREPLACE

This manual and particularly the preceding and following pages contain very important information regarding the safe operation of your fireplace as well as maintenance instructions. Read carefully before operating your fireplace and pay special attention to the safety warnings.

A heating gas appliance does require safe handling. For this reason, we very strongly recommend children are not allowed to touch the fireplace or controls. **Install a screen or barrier in front of the fireplace to protect your children against severe burns.**

This appliance is designed and approved as a supplemental heater and provides the potential for most energy conservation when used while attended. The use of an alternate primary heat source is advisable.



WARNING EXTREMELY HOT!!!

- **Read the safety information on pages 3 and 4 of this manual before operating your gas heater.**
- Some parts of your fireplace are **extremely hot**, particularly the **glass** window.
- **Do not let children touch the glass** or any parts of your fireplace **even after it is turned off** as it is still hot.
- **Use the barrier screen** provided with the trim or a gate to reduce the risk of severe burns.
- Keep the remote control handset **out of reach of children.**
- **Hot hearth/floor surface!** The hearth or floor directly in front of the fireplace is very hot when the fireplace heats. Even if constructed of non-combustible materials, and although safe, it may reach temperatures **in excess of 200° F** depending on choice of materials. **Do not step on it!**
- Some materials or items, although safe, may discolor, shrink, warp, crack, peel, and so on because of the heat produced by the fireplace. **Avoid placing** candles, paintings, photos, and other items **sensitive to heat** within 36 inches (0.9 m) around the fireplace.
- Solid wood flooring in front of the fireplace (if allowed) may shrink during the heating season due to heat.

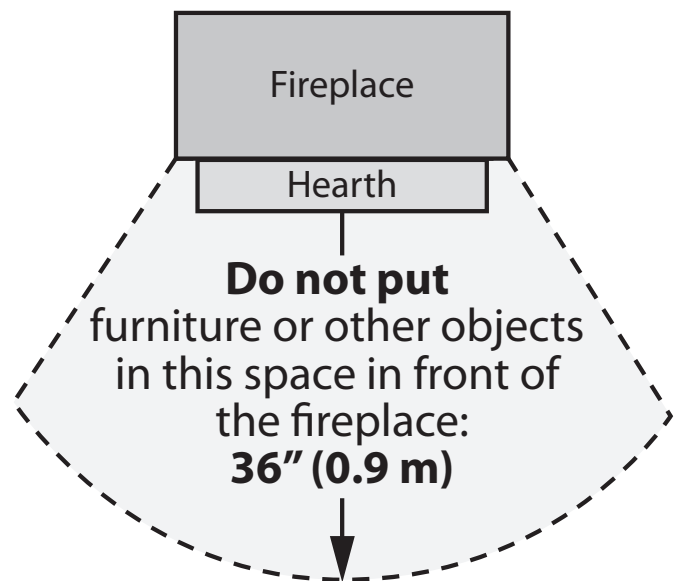

Thank You ...

For purchasing a Valor by Miles Industries. Your new radiant gas heater is a technical appliance that must be installed by a qualified dealer. Each Valor fireplace is fully tested during the production process for your safety and comfort.

Your unit has been professionally installed by:

Dealer Name: _____

Phone Number : _____

Should you encounter an operational problem, call your dealer immediately.

Do not try to repair the unit as you may cause an injury or damage the fireplace.

Locating Fireplace & Lighting Information Card

⚠ WARNING

DO NOT ATTEMPT TO TOUCH THE DATA CARD WHILE THE FIREPLACE IS STILL HOT! Let the fireplace cool first before touching it.

The Fireplace and Lighting Information card is located under the firebox.

To access the plate, remove any fret or access panel and grab the plate and slide it out to read it. There is important information on both sides of the plate.

Fireplace model

Serial number



MILES INDUSTRIES LTD SOUTH MISSISSAUGA ON L4X 1L3 CANADA		NET RATING: Max 24,000 Btu/hv
MODEL/MODELE 739MN		NET CALORIFIC VALUE Min 6,500 Btu/hv
FOR NATURAL GAS / POUR LE GAZ NATUREL		
DESIGN No. 739N 10000	HEATING POWER IN kW 3.2"	HEATING POWER IN BTU/HOUR 5.0"
MINIMUM CLEARANCE TO COMBUSTIBLE CONSTRUCTION 739N 10000	MINIMUM SUPPLY PRESSURE (kPa) 750	MINIMUM SUPPLY PRESSURE (in. H ₂ O) 3.0"
INSTALLER'S NAME: _____	INSTALLER'S ADDRESS: _____	INSTALLER'S PHONE: _____
INSTALLER'S SIGNATURE: _____	INSTALLER'S DATE: _____	INSTALLER'S LICENSE NO.: _____
<p>WARNING: THIS INFORMATION IS NOT TO BE USED WITH A FLUE GAS SYSTEM THAT IS NOT APPROVED BY MILES INDUSTRIES LTD. FOR THIS APPLIANCE. ALWAYS USE THE APPROVED FLUE GAS SYSTEM FOR THIS APPLIANCE. ALWAYS USE THE APPROVED FLUE GAS SYSTEM FOR THIS APPLIANCE.</p>		

Operating Your Fireplace for the First Time

When operating your new fireplace for the first time, some vapors may be released due to the burning of curing compounds used in the manufacture of the appliance. They may cause a slight odor and could cause the flames to be the full height of the firebox, or even slightly higher, for the first few hours of operation.

It is also possible that these vapors could set off any smoke detection alarms in the immediate vicinity.

These vapors are quite normal on new appliances. We recommend opening a window to vent the room. After a few hours use, the vapors will have disappeared and the flames will be at their normal height.

Flame Supervision Device

For your safety, this appliance is fitted with a flame supervision device which will shut-off the gas supply if, for any reason, the pilot flame goes out. This device incorporates a fixed probe, which senses the heat from the pilot flame. If the probe is cool, the device will prevent any gas flow unless manually lighting the pilot. See full lighting instructions on page 13 of this manual.

Performance of propane gas appliances may be affected by the quality of commercial gas supplied in your area.

Operating Your Fireplace

Fireplace Control Devices

There are three ways to control your fireplace.

1. Thermostatic Remote Control;
2. Manual On/Off Switch;
3. Wall Switch (optional) .

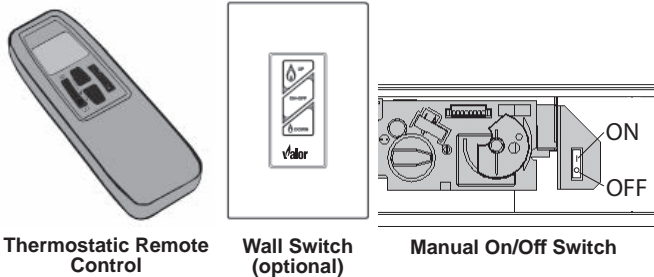

The Thermostatic Remote Control can be programmed to function automatically—see page 8.

The manual On/Off switch must be ON for the fireplace to function. It can be used to shut off the fireplace in case of emergency—see below.

The Wall Switch (optional) can be used to turn on, off and to increase or decrease the flame height—see 1265WSK or RBWSK—Wall Switch Kit.

NOTE: The remote control in the AUTO mode will override the wall switch.

How to Turn Your Fireplace OFF (including pilot)

Familiarize yourself with each of these methods before operating your fireplace.

Handset and Wall Switch: Press and hold the OFF button for a second (either on the handset or the wall switch).

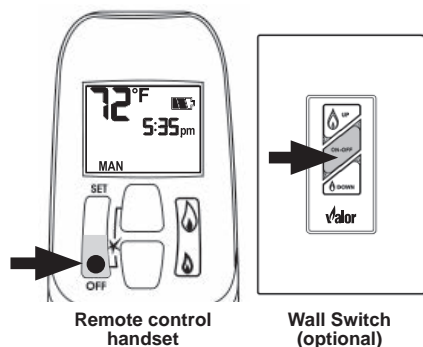

If the flames are on, they go down and you hear the valve motor wind down. You hear a clunk and a beep indicating that the valve has received the signal from the remote control.

In the unlikely event that you cannot turn off your fireplace with the remote control handset, use the wall switch (if installed); if the wall switch malfunctions and will not turn off the fireplace, wait 6 hours and the fireplace will automatically go to pilot. You can then access the controls inside your fireplace. Alternately, turn off gas supply. In all cases, call your dealer for service assistance.

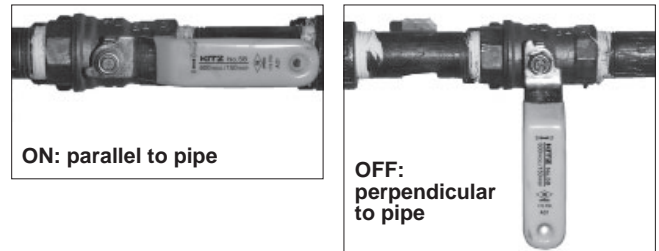

How to Ensure Your Fireplace Cannot Be Turned ON Inadvertently

You can use one of the two following methods to ensure that your fireplace will not turn on when you don't want it on.

⚠ WARNING

RISKS OF SEVERE BURNS! SURFACES OF THE FIREPLACE ARE VERY HOT DURING OPERATION! Be very careful and wear gloves to access controls.

- You can prevent your fireplace from lighting by pressing the **O** button on the manual ON/OFF switch on the gas valve.

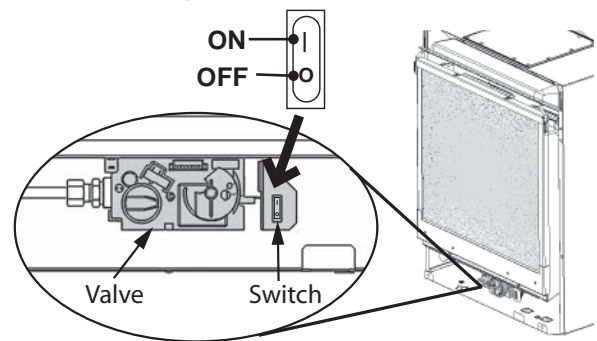

- Alternately, you can remove all batteries from the receiver as well as the battery from the handset.

Automatic Shut-Off (in certain conditions)

Your fireplace's remote control is equipped with an automatic shut-off mechanism which is activated in certain conditions. See page 11 in the *Using the Remote Control* section for a description of this feature.

Using the Remote Control

Radio Frequency

315 MHz for USA and Canada.

This device complies with Part 15 of the FCC Rules and with Industry Canada license-exempt RSS standard(s). Operation is subject to the following two conditions:

- (1) this device may not cause harmful interference, and
- (2) this device must accept any interference received, including interference that may cause undesired operation.

NOTE: Before using the remote control system for the first time, the receiver and the handset must be synchronized. See the section *Synchronize Remote Control* on page 1.

IMPORTANT: BEFORE YOU BEGIN, please note that on this system, the settings of time, temperature and automatic ON/OFF **can only be programmed when the function display is flashing**. Be patient when programming as it can take a few seconds to set.

Note: In the TEMP or TIMER modes, the remote handset senses the room temperature and adjusts the flame accordingly.

To communicate, the handset should be within 15 feet (4.5 meters) of the fireplace.

Do not leave the handset on the mantel or hearth.

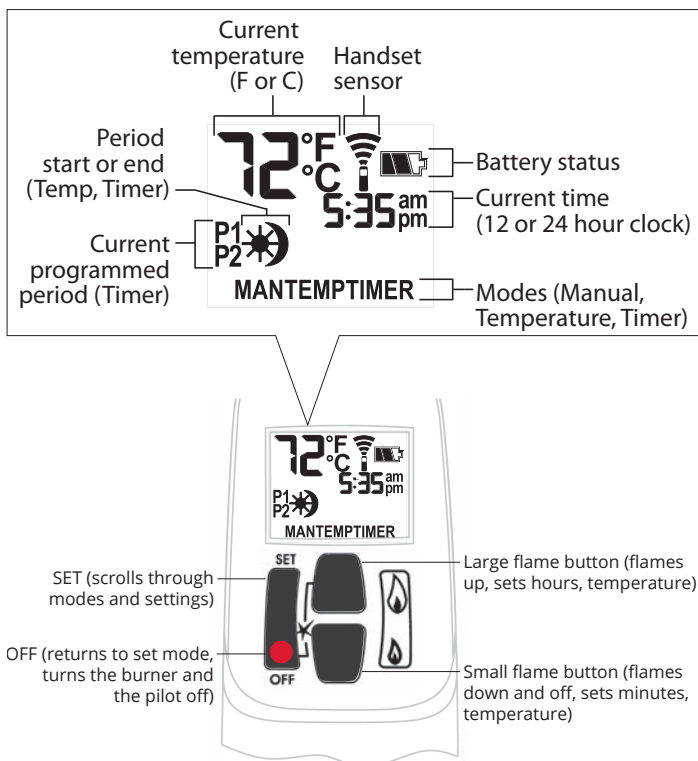

Turn Fireplace ON

Press ● + 🔥 buttons until you hear a short beep; release buttons.

Beeping continues until pilot is lit.

Burner lights to maximum flame height and handset goes automatically to manual (MAN) mode.

NOTES:

On the valve, MAN button must be at ON, in full counter-clockwise position .

ON/OFF switch (if equipped) must be in I (ON) position.

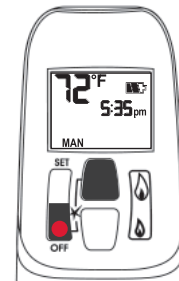

Turn Fireplace OFF

Press ● button.

When pilot is just turned off, wait 2 minutes to light it again.

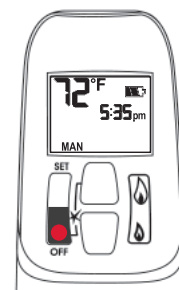

Standby Mode (Pilot Flame)

Press and hold 🔥 to set fireplace to pilot.



Adjust Flames Height

With pilot lit, press and hold buttons:

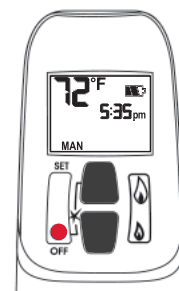

-  = increase flame height
-  = decrease flame height or set to pilot

For fine adjustment, tap buttons.



Express Low and High Fire

Double-click buttons:

-  = increase flame to maximum height "HI"
-  = decrease flame minimum height "LO"

NOTE: Flame goes to high fire first before going to designated low fire.

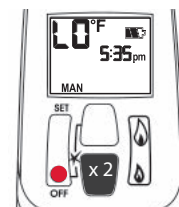
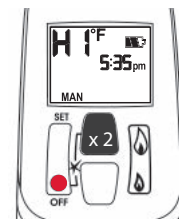

Using the Remote Control

Setting °C/24-hr or °F/12-hr clock

In MAN mode, press and hold ● + 🔥 buttons until temperature / clock display changes from

°F / 12-hour ↔ °C / 24-hour

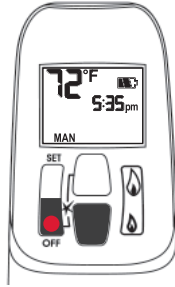

Setting Time

The time display will flash after either:

- installing the battery, or
- pressing 🔥 + 🔥

To set the time, press buttons:

🔥 = hour

🔥 = minutes

Press ● or wait to go back to MAN.

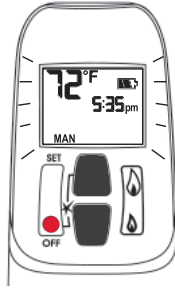

Modes of Operation

Briefly pressing SET cycles through modes of operation.

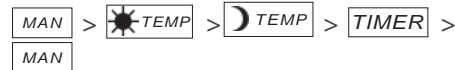

NOTE: Press 🔥 or 🔥 to reach MAN mode.

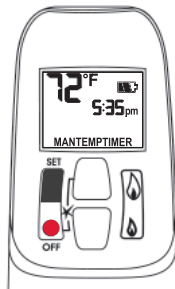

MAN Manual Mode

Manual flame height adjustment.



⚡TEMP Daytime Temperature Mode

When pilot is lit, room temperature is measured and compared to set temperature. Flame height automatically adjusts to reach Daytime Set Temperature.



🌙TEMP Night time Setback Temperature Mode

When pilot is lit, room temperature is measured and compared to set temperature. Flame height automatically adjusts to reach Night Time Setback Temperature.

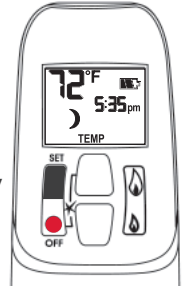

TIMER Timer Mode

When pilot is lit, two periods of time (P1 and P2) can be programmed to use Daytime and Night time temperatures at specific times.

Note: Display shows set temperature every 30 seconds.

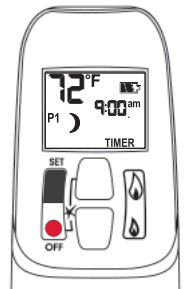

Set the different parameters when they are flashing.

Using the Remote Control

Setting high / low Temperatures

Setting "DAYTIME" high temperature.

Default Settings:  TEMP 23 °C/74 °F

Press SET to scroll to  TEMP

Hold SET button until TEMP flashes.

To set  Daytime Temperature:

 = increases temperature.

 = decreases temperature.

Press  or wait to complete setting.

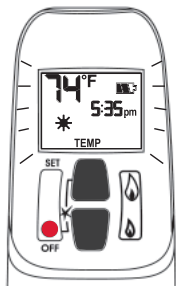

Setting "NIGHT TIME SETBACK" low temperature.

Default Settings:  TEMP "--" (OFF)

Press SET to scroll to  TEMP

Hold SET button until TEMP flashes.

To set  Night Time Temperature:

 = increases temperature.



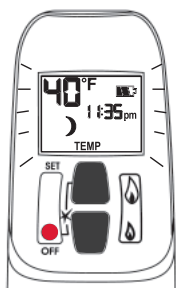

 = decreases temperature.

Press  or wait to complete setting.



Setting Program Timers



You can program two periods of time between 12 am and 11:50 pm in each 24-hour cycle.

Programs P1 and P2 must be set in the following order during a 24-hour cycle: **P1** , **P1** , **P2**  and **P2** .

 = Day Time temperature (high) program period

 = Night Time temperature (low) program period





Default Settings:



Program 1: **P1**  06:00 am **P1**  08:00 am





Program 2: **P2**  11:50 pm **P2**  11:50 pm

Press SET to scroll to .



If **P1**  = **P1**  or **P2**  = **P2** , programming is cancelled.

To keep fireplace ON all night, set **P2**  at 11:50 am and **P1**  at 12:00 am.

If you want to program only one period, program **P1**  and **P1**  with desired times then **P2**  and **P2**  with the same time as **P1** .

Setting P1 time—high temperature.

Hold SET button until **P1**  is displayed and time flashes.

To set time:

 = hour

 = minutes

Press  or wait to complete setting.

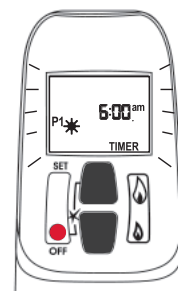

Setting P1 time—low temperature.

Hold SET button until **P1**  is displayed and time flashes.

To set time:

 = hour

 = minutes

Press  or wait to complete setting.

Using the Remote Control

Setting P2 high and low temperature times.

Repeat same steps as Setting P1.

When all settings are complete, press ● to save them.

Timer Programming Example (default temperatures shown)

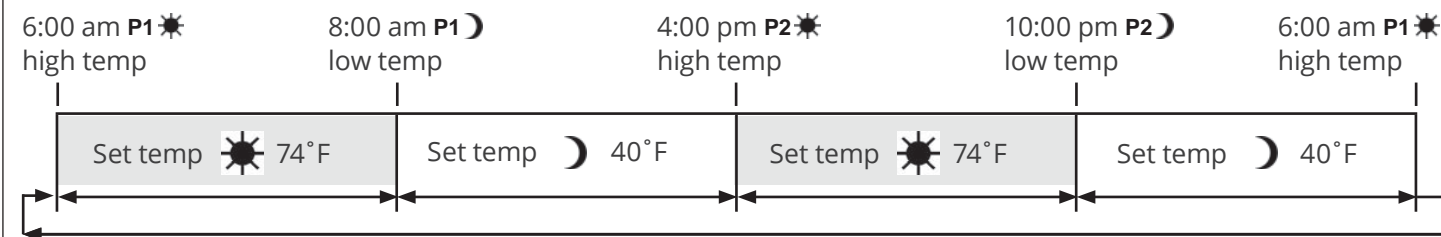

Automatic Turn Down

8 Hour no Motor Movement

The valve will turn to pilot flame if there is no motor movement for an 8-hour period.

Automatic Shut-Off

Low Batteries Receiver. With low battery power in the battery holder the system shuts off the fire completely. This does not apply when the power supply is interrupted.

On-Demand Pilot (7 Day Shut-Off). This green feature eliminates gas energy consumption during extended appliance inactivity. When the appliance is inactive for an extended period of time the system automatically extinguishes the pilot. This feature helps the consumer realize cost benefits by automatically eliminating energy consumption during non-heating months and limited use.

The programmed length of inactivity to activate the system is specified by the appliance manufacturer and cannot be altered in the field.

Low Battery Indication

⚠ Caution

DO NOT USE a screwdriver or other metallic object to remove batteries from holder. This could cause a short-circuit.

Handset: The battery icon  will show when the battery needs to be replaced. Replace with one 9 V **alkaline** battery.

Battery holder: Frequent 'beeps' for 3 seconds when the valve motor turns indicate the batteries need to be replaced in battery holder. Replace with four 1.5 V **alkaline** batteries.

Handset / Receiver Match

The remote control handset and receiver are programmed to function together. In case of a replacement of the handset or the receiver, you will need to reset the receiver to allow them to function together. Contact your dealer for details.

Required Kits

Information accurate at the time of printing and subject to change without notice.

Fuel Beds (choose one)	
530LSK	Traditional Logs & Reversible Liners Set
530RSK	Rocks & Reversible Liners Set
530CSK	Coals & Reversible Liners Set
530DWK	Driftwood & Reversible Liners Set

Fronts/Stoves (choose one)	Barrier Screen Number	
Zero Clearance Installations		
536CXB	President ZC Front	4006382
539/549/550	Arches Windsor and Classique	4003290
541BPC	Bolero Front	4003289
545CFVZC	Clearview ZC Front	4005146
563CSB	Senator Front	4003291
569	Ledge Fronts	4003375
Insert Installations		
536CXBI	President Insert Front (closure plate 582 or 583 required)	4006382
545CFV	Clearview Insert Front (closure plate 582 optional)	4005146
546	Ledgeview Insert Fronts	4005099
Free Standing Stoves		
531CSB	President Stove FS	4006382
575-576-578	Lift Stove FS	4003429

Optional Accessories

Information accurate at the time of printing and subject to change without notice.

Gas Conversion Kits	
530NGK	Conversion kit to natural gas
530PGK	Conversion kit to propane gas

Other Accessories	
GV60CKO	Outdoor Fireplace Conversion Kit
582CPB	Closure Plate black 26"W x 31"H (use with 536CXBI or 545CFV)
583CPB	Closure Plate black 30"W x 33"H (use with 536CXBI)
567FGP	Top Grille (with logs, driftwood and rocks ONLY)
580RGL	Reflective Glass Liners (Installs on top of liners supplied with fuel beds)
556CLA	Co-Linear Adapter
555CFK	Circulating Fan Kit
1265WSK	Wall Switch Kit
GV60PAK	AC Adapter
Hearth Gate	Hearth gates such as Cardinal's VersaGates are available at retail stores carrying safety products for children.

Lighting Instructions

FOR YOUR SAFETY, READ BEFORE LIGHTING

WARNING: If you do not follow these instructions exactly, a fire or explosion may result causing property damage, personal injury or loss of life.

A. This appliance has a pilot which must be lighted by hand or by remote control. Follow these instructions exactly. To save gas, turn the pilot off when not using the appliance for a prolonged period of time.

B. **BEFORE LIGHTING**, smell all around the appliance area for gas. Be sure to smell next to the floor because some gas are heavier than air and will settle on the floor.

WHAT TO DO IF YOU SMELL GAS

- Do not try to light any appliance.
- Do not touch any electric switch; do not use any phone in your building.
- Immediately call your gas supplier from a neighbor's phone. Follow the gas supplier's instructions.
- If you cannot reach your gas supplier, **call the fire department.**

C. Use only your hand to push in or turn the control knobs. Never use tools. If the knobs will not push in or turn by hand, **don't try to repair them; call a qualified service technician. Force or attempted repair may result in a fire or explosion.**

D. Do not use this appliance if any part has been under water. **Immediately call a qualified service technician** to inspect the appliance and to replace any part of the control system and any gas control, which has been under water.

LIGHTING INSTRUCTIONS

1. STOP! Read the safety information above. Dependent on model, switch #1 may be mounted directly to valve see Fig 2A.

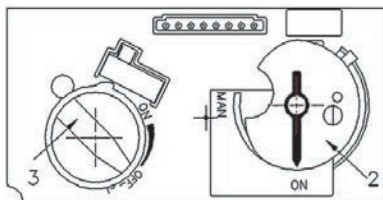

Fig 1

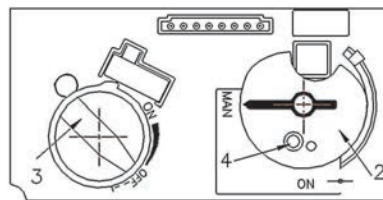

Fig 2

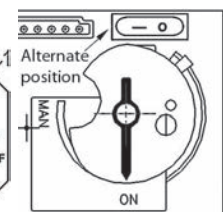



Fig 2A

2. SET ON/OFF SWITCH (1) TO "OFF" POSITION.

- Wait five (5) minutes to clear out any gas, then smell for gas, including near the floor. If you smell gas, STOP! Follow "B" in the safety information above on this label. If you don't smell gas, go to the next step.

3. **AUTOMATIC IGNITION (fig. 1):** Locate the pilot (fig 3.) inside of firebox at Left Hand side.

- ON/OFF switch (1) in ON position, MAN-knob (2) in ON position; set Flame Adjustment knob (3) to lowest setting (∩);
- On the remote control handset, press and hold the 'off' button and  (large flame) simultaneously; a short acoustic signal confirms the start has begun;
- Further short acoustic signals indicate the ignition process is in progress;
- When the pilot is lit, the Flame Adjustment knob (3) will automatically rotate to the highest setting.
- Press the  (small flame) on the remote control handset to reduce the flame height.

4. **MANUAL IGNITION (fig. 2):** With the window off, locate the pilot (fig. 3) inside of firebox at Left Hand side;

- ON/OFF switch (1) in ON position, MAN-knob (2) in MAN position;
- Set Flame Adjustment knob (3) to the lowest setting (∩);
- Push down the metallic core (4) with a pen or similar instrument; this will establish the pilot gas flow;
- **Light gas at the pilot (5) with a match;**
- Continue holding down metal core (4) for about 10 seconds; after release, pilot should remain lit;
- If the pilot will not stay lit after several tries, turn the gas control knob (3) to "OFF" (∩) and call your local service technician or gas supplier.

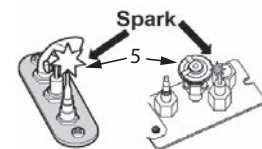

Fig 3

Continue holding down metal core (4) for about 10 seconds; after release, pilot should remain lit;

- If the pilot will not stay lit after several tries, turn the gas control knob (3) to "OFF" (∩) and call your local service technician or gas supplier.

Reinstall the window and set the MAN-knob (2) to "ON"; turn Flame Adjustment knob (3) up (∩) or down manually or use the up/down 'flame' buttons on the remote control handset to adjust the flame height.

TO TURN OFF GAS TO APPLIANCE

1. **AUTOMATIC SHUT-OFF (using the remote control handset):**

- Press and hold the  (small flame) on the remote control handset to shut-off the main burner gas flow;
- Press "OFF" button on remote handset to shut-off the appliance, including pilot flame.

2. **MANUAL SHUT-OFF (using only the ON/OFF switch (1))**

- Press "O" the ON/OFF switch (1) to shut-off the appliance.

Servicing Your Fireplace

We recommend having your fireplace serviced every year. Contact your supplier quoting the model number. It will be helpful if the appliance's serial number can also be quoted. These numbers are on the information card. The replacement parts are shown at the end of this manual. Please always quote the part number and description when requesting spare parts.

Annual Inspection

In order to maintain the safe operation of your fireplace, contact your dealer to have a qualified technician go over the list below and make the necessary verifications at least once every year.

Safe Operation List

To be performed by a qualified technician only

1. Inspect and operate the pressure relief mechanism to verify relief mechanisms are free from obstruction to operate. See *Cleaning Your Fireplace: To refit the window* section of this manual.
2. Clean glass window with a suitable fireplace glass cleaner. Abrasive cleaners must not be used. Be careful not to scratch the glass when cleaning. See *Cleaning Your Fireplace* section of this manual.
3. Inspect the operation of the flame safety system Pilot or Flame rectification device.
4. Inspect and ensure the lighting of the main burner occurs within 4 seconds of the main gas valve opening. Visual inspection should match that outlined in the appliance instruction manual. Inspect primary air openings for blockage. See *Checking Pilot and Burner Flame* section of this manual.
5. Inspect condition of vent and vent terminal for sooting or obstruction and correct if present.
6. Vacuum and clean any debris in the firebox that is not supposed to be there.
7. Test and measure the flame failure response time of the flame safety system. It must de-energize the safety shutoff in no more than 30 seconds.
8. Check all accessible gas-carrying tubes, connections, pipes and other components for leaks. See *Set up Gas Supply* section of this manual.

Cleaning Your Fireplace

⚠ WARNING

DO NOT TOUCH THE GLASS WHILE IT IS HOT!
Let the fireplace cool first before cleaning it.

Important - Glass cleaning - Mineral deposits

One of the by-products of the combustion process in a gas appliance is a mineral which can show up as a white film on the ceramic glass of the viewing door.

The composition of the deposit varies with location and time. It is believed to be associated with the varying sulfur content of the gas. You may have the problem intermittently.

We have consulted with ceramic glass manufacturers and they cannot offer a definitive solution to this problem. Dealers have tried various cleaning products with varying results. The following are recommendations only and are not meant to guarantee results.

NOTE: This is a problem beyond Miles Industries' control and is not covered under warranty.

- Clean the glass regularly as soon as you notice the buildup (white film). If the film is left for a longer period of time, it will etch into the glass. It is then much harder, if not impossible, to remove.
- **NEVER use an abrasive cleaner or ammonia-based cleaner on the ceramic glass.** Any abrasion of the surface has the immediate effect of compromising the strength of the glass. An emulsion type cleaner is recommended.
- Use a soft damp cloth to apply the cleaner. Dry the glass with a soft, dry, preferably cotton cloth. Most paper towels and synthetic materials are abrasive to ceramic glass and should be avoided.
- Our dealers have had good results from the products listed below. We cannot, however, guarantee the results of these products.
 - Brasso, Polish Plus by Kelkem, Cook Top Clean Creme by Elco, White Off by Rutland, Turtle Wax

Do not clean the glass while it is hot!

Always securely replace the window and the barrier screen before lighting.

If broken, the glass pane may only be replaced as a complete window unit as supplied by the manufacturer.

If the barrier becomes damaged, the barrier shall be replaced with the manufacturer's barrier for this appliance.

Clean the window panes following the guidelines in this section.

Clean the steel trim with mild soap and warm water. Any alcohol/solvent base cleaner will weaken the coating and damage it.

Clean the barrier screen dusting it with a soft brush.

Clean the firebox ceramic logs/rocks and walls dusting them with a soft brush. Dust can also be removed from the burner using a soft brush after removing the fuel bed. **When cleaning, make sure that no particles are brushed into the slots of the burner.**

To remove the window for cleaning:

1. Unhook the front and barrier screen.
2. Release the top of the window by pulling forward and unhooking the two clamping bars at the top corners.
3. Unscrew the two spring-loaded bolts securing the bottom of the window.

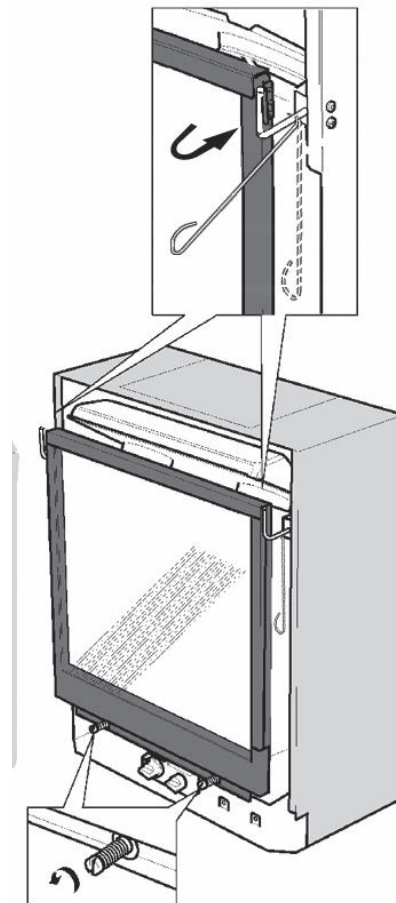

4. Carefully lift the window. Keep the window and bolts in a safe place.

To refit the window:

! DANGER

The window unit must be correctly installed, fastened and sealed after servicing or serious bodily injury and/or damage to the appliance may result.

To ensure a safe operation:

- Double-check that the bottom of the window frame is correctly bolted at the bottom;
- Verify that the levers are hooked properly to the window tabs then;
- Pull out the top and bottom of the window and release it to insure the springs return it;
- Ensure the window is sealed before operation.

! WARNING

Failure to install the window correctly can leak carbon monoxide, affect the performance of the fireplace, damage components, cause overheating resulting in dangerous conditions. Damage caused by incorrect window installation is not covered by the Valor warranty.

1. Place the window centrally against the engine unit resting it on the support at bottom front of the engine.
2. Pull the clamping bars forward and hook them to the window frame bracket to secure the top of the window.
3. Fit the two spring loaded bolts through the bottom of the window and tighten to secure the bottom of the window.

4. Pull the top of the window forward and release to ensure the springs return it in position.
5. Similarly check the bottom of the window by pulling it forward and releasing.

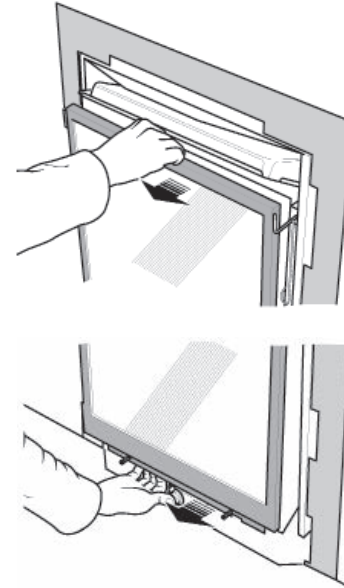

6. Apply firm hand pressure around the window frame to ensure the window is sealed tight against the firebox.
7. **If the Hot Glass Warning plate has been removed from the front lower corner of the window, reinstall it by sliding it between the glass and the frame as indicated.**



8. Reinstall the front and barrier screen.

! WARNING

FOR SAFETY PURPOSE, ensure the barrier screen is re-installed on the fireplace front after maintenance.

Servicing & Maintenance

Checking Pilot and Burner Flames

A periodic check of the pilot and burner flames should be made. Check after the fire has been on for at least 30 minutes. The pilot flame must cover the tip of the thermocouple probe. The main burner flame pattern will vary from appliance to appliance depending on the type of installation and climatic conditions.

The appliance area must always be kept clear and free from combustible materials, gasoline and other flammable vapors and liquids. Inspect the vent terminal outdoors regularly to make sure that dirt, snow, insects, leaves, shrubs, trees do not obstruct it. Examine the whole vent system regularly. We recommend annually.

Correct flame appearance



530LSK—Traditional Logs

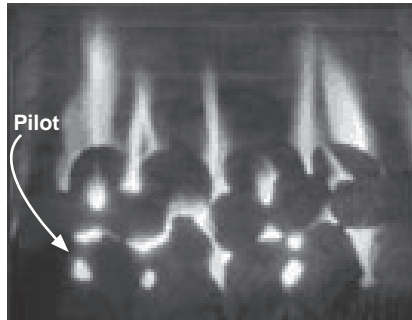

530CSK—Coals

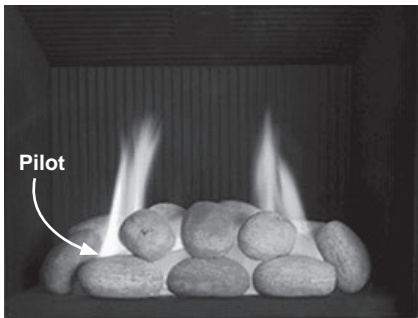

530RSK—Rocks



530DWK—Driftwood

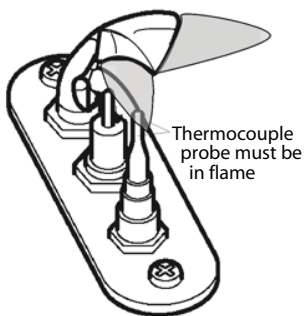

Replacing Batteries

⚠ WARNING

DO NOT ATTEMPT TO CHANGE THE BATTERIES WHILE THE FIREPLACE IS STILL HOT! Let the fireplace cool first before touching it.

CAUTION

DO NOT USE a screwdriver or other metallic object to remove the batteries from the receiver or the handset! This could cause a short circuit to the receiver.

Low battery signal: see page 11.

BEFORE changing the batteries, **turn off the valve using the manual On/Off switch**—see instructions on page 7.

The appliance uses four 1.5 V AA **alkaline** batteries for its remote control receiver and one 9 V **alkaline** battery for its handset. The batteries should last one to two seasons, depending on usage. Removing the batteries in the off-season will extend the battery life. Should the batteries lose power, the control may be operated by manually turning the control knob at the valve or by turning off the valve at the switch.

To replace the batteries in the battery holder

1. The battery holder is located below the firebox on the right hand side. Remove the front trim. Grab the battery holder and pull it out from its location.

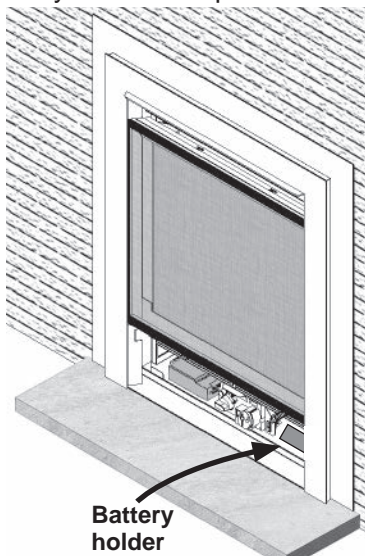

2. Disconnect the battery holder from the cable.

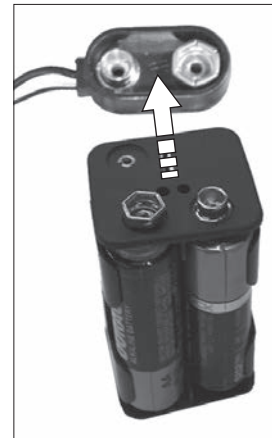

3. Replace the batteries with 4 AA **alkaline** batteries.
4. Reconnect the cable.
5. Put the battery holder back in its position.
6. Reinstall the front trim.

Using Handset Wall Holder

Your fireplace equipment includes a wall holder to store the handset. If it hasn't been installed, refer to the instructions further on in this manual for the installation.



Approvals and Codes

This appliance is certified to ANSI Z21.88 / CSA 2.33 American National Standard/CSA Standard for *Vented Gas Fireplace Heaters* for use in Canada and USA.

The appliance complies with CSA P.4.1-15, *Testing method for measuring annual fireplace efficiencies*.

The installation must conform with local codes or, in the absence of local codes with the *National Fuel Gas Code*, ANSI Z223/NFPA 54.1 or the *Natural Gas and Propane Installation Code* CAN/CGA-B149.1. Only qualified licensed or trained personnel should install the appliance.

The appliance, when installed, must be electrically grounded in accordance with local codes or, in the absence of local codes, with the *National Electrical Code*, ANSI/NFPA 70 or the *Canadian Electrical Code*, CSA C22.1.

Ratings

Model	IN	IP
Gas	natural	propane
Altitude (ft)*	0-4 500 pieds*	
Input max. (Btu/h)	20,500	19,000
Input min. (Btu/h)	6,500	12,500
Manifold pressure (in w.c.)	3.5–3.9	10.3–10.7
Min. supply pressure (in w.c.)	5	11
Max. supply pressure (in w.c.)	10.5	14
Main burner injector (no.)	580	200
Pilot injector (no)	35	27
Min. by-pass screw	125	125

*Tested to CGA - 2.17-91 *Gas fired appliances for use at high altitudes*. In USA, installations may require deration over 2000'—Check local codes.

*High Altitude Installations

Input ratings are shown in BTU per hour and are certified without deration for elevations up to 4,500 feet (1,370 m) above sea level.

For elevations above 4,500 feet (1,370 m) in USA, installations must be in accordance with the current ANSI Z223.1 and/or local codes having jurisdiction. Heating value of gas in some areas is reduced to compensate for elevation—consult your local gas utility to confirm.

For installations at elevations above 4,500 feet (1,370 m) in Canada, please consult provincial and/or local authorities having jurisdiction.

Supply Gas

Heater engine 530IN is used for natural gas installations. Heater engine 530IP is used for propane gas installations.

The supply pressure must be between the limits shown in the *Ratings* table on the previous page.

The supply connection is 3/8 inch NPT female located at the left side of the control valve. The opening for the gas supply line is at the rear left corner of the appliance.

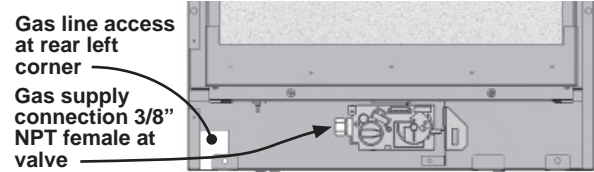

Fuel Beds

The 530 engine is available in either natural gas or propane gas can use a simulated logs, coals, rocks or driftwood fuel bed in either fuel.

Electrical

The unit does not require an electrical power source unless fitted with an optional circulating fan.

Floor/Hearth

This appliance is approved for installation directly on combustible material such as plywood and so on. Vinyl, carpet, and soft flooring require sheet metal extending the whole width and depth under the appliance. This appliance does not require a hearth. Combustible flooring may extend up to the front of the unit.

Front Trims/Stove

Various fronts are available for the 530 engine. This engine may be installed as a free standing, zero clearance or insert application depending on which style front trim is selected. **The front trim/stove style affects the framing cavity, clearances and position of the engine. A front trim kit is required for all applications and should be on site when the engine is installed** as the parts to make the engine suitable for zero clearance are supplied with the front trim kits (except 549 front).

Outdoor Conversion Kit

The 530IN/IP ZC model is supplied standard for indoor applications and may be adapted for installation in specific “outdoor” applications protected from weather as defined in the GV60CKO outdoor conversion kit manual.

⚠ WARNING

Optional electrical accessories ARE NOT ALLOWED when adapting appliance for outdoor use.

This appliance is designed and approved as a supplemental heater and provides the potential for most energy conservation when used while attended. The use of an alternate primary heat source is advisable.

Dimensions, Clearance and Framing

The dimensions, clearances and framing vary with each applications and with the front trim installed. Refer to the installation instructions of the front trim chosen for more information.

Non-Combustible Materials Specifications

Material which will not ignite and burn. Such materials are those consisting entirely of steel, iron, brick, tile, concrete, slate, glass or plasters, or any combination thereof.

Materials that are reported as passing ASTM E 136, Standard Test Method for Behavior of Materials in a Vertical Tube Furnace at 750 °C.

Combustible Materials Specifications

Materials made of or surfaced with wood, compressed paper, plant fibers, plastics, or other material that can ignite and burn, whether flame proofed or not, or plastered or unplastered.

⚠ WARNING

Some materials or items, although safe, may discolor, shrink, warp, crack, peel, and so on because of the heat produced by the fireplace. Avoid placing candles, paintings, photos, and other items sensitive to heat around the fireplace.

⚠ WARNING

HOT HEARTH / FLOOR! The hearth or floor in front of the fireplace may become very hot when the fireplace heats. Do not use the hearth as a seat or shelf. Solid wood flooring in front of the fireplace (if allowed) may shrink during the heating season due to heat.

Venting

Top or Rear Outlet

The 530 engine unit is supplied standard with a rear direct vent outlet and may be converted to a top direct vent outlet with no extra parts required—see *Conversion to Top Outlet for Solid Direct Vent Co-axial Piping* in the *Appliance Preparation* section further on in this manual.

The 530 heater is supplied with a smooth 4-by-6-5/8-inch co-axial collar and will require an 817VAK Vent Adapter to convert the collar to a twist-lock type collar. All manufacturers' components listed have designed their components to fit this twist-lock type collar.

Do not mix components from different manufacturers.

Do not cut pipe lengths. Use adjustable lengths otherwise.

Vent Material

This unit is approved for installation using 4 x 6-5/8 inches approved co-axial direct vent pipes and accessories listed on pages 46–47 of this guide. Follow the installation instructions supplied with the individual venting accessories.

This unit may also be converted to co-linear venting with two 3-inch pipes for use in solid-fuel burning fireplaces and chimneys using approved adapters and accessories listed on pages 46–47 of this guide.

Vent Sealing

Seal all outer coaxial pipe and elbow joints, including sectioned elbow joints, using high quality, high temperature 2 inch wide self-adhesive aluminum foil tape (Nashua-322-2 brand or similar). Wrap the tape completely around all joints and press firmly to seal.

A high temperature black silicone sealant may be used in the outer joints as a substitute to foil tape.

Ensure all the pipe joints have a minimum of 1 ¼ inch overlap.

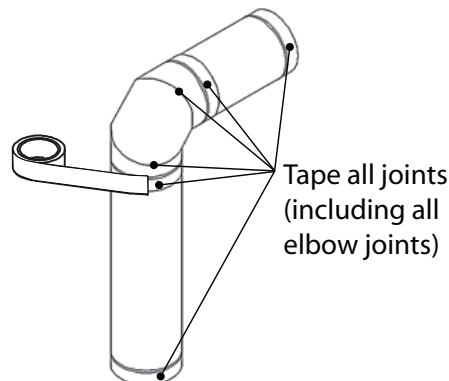

Venting

Wall Thickness

The appliance vent is suitable for penetrating a combustible wall up to 14 inches (36 cm) thick.

A non-combustible wall can be any thickness up to the maximum horizontal run of vent pipe allowed for the particular installation—see page 23.

Vent Penetration through Walls & Ceilings

Combustible: When penetrating through combustible walls and ceilings, frame a minimum of 10 inch x 10 inch opening and ensure that the insulation is kept clear of the vent pipe using either a wall thimble or an attic insulation shield. Follow the installation instructions supplied with the individual venting components.

Non-combustible: If the wall is totally non-combustible (e.g. masonry block or concrete), mark for a 7 inch circular hole.

In both cases, the center of the hole should line up with the center line of the horizontal vent.

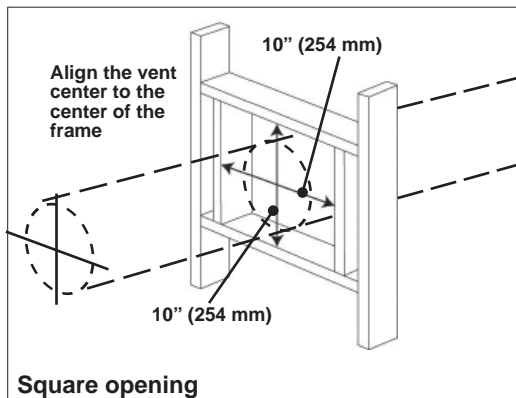

All horizontal pipe runs must be graded 1/4 inch per foot upwards in the direction of the exhaust flow. The final pipe length, when terminating through the wall may be graded downwards slightly to prevent water migration.

Co-Linear Direct Vent Installations for Free Standing or Recessed Installations (flexible piping)

Converts the appliance outlet collars to accept two 3-inch diameter flexible liners for installation into existing solid-fuel burning fireplaces and chimneys. Requires a co-linear adapter at the appliance and either a co-linear terminal or co-linear-to-co-axial terminal at the top of the chimney. Sidewall co-linear installation is also possible using a 720WSK Sidewall Terminal Kit—see instructions packaged with the 720SWK. A list of approved venting accessories is shown starting on page 47 of this manual.

Co-Axial Venting

Typical Co-Axial Venting Components

See venting accessories list starting on page 47 for allowable components.

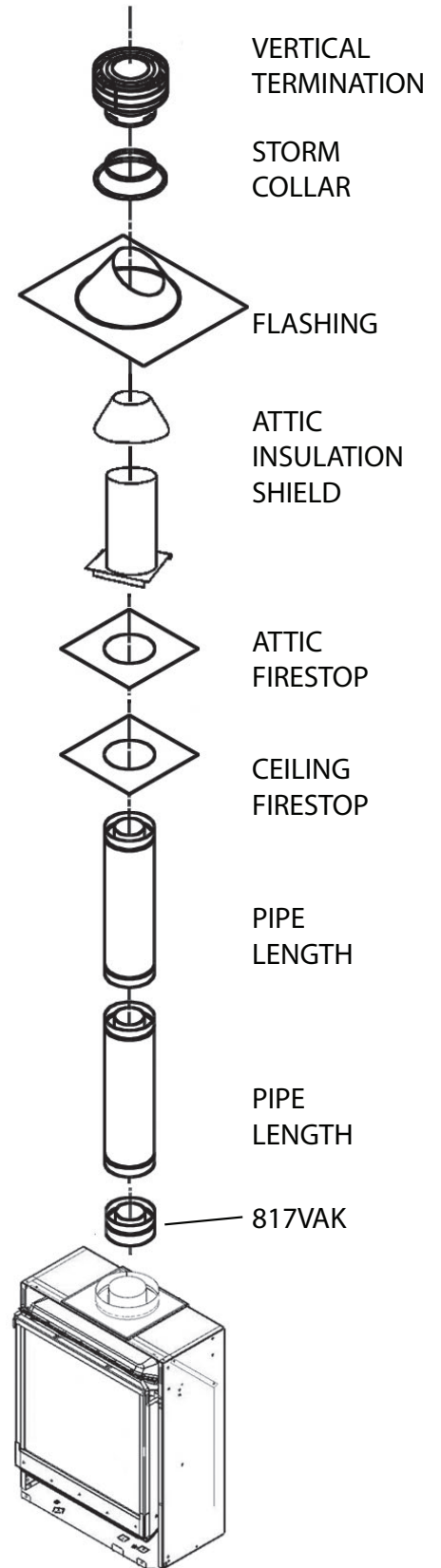
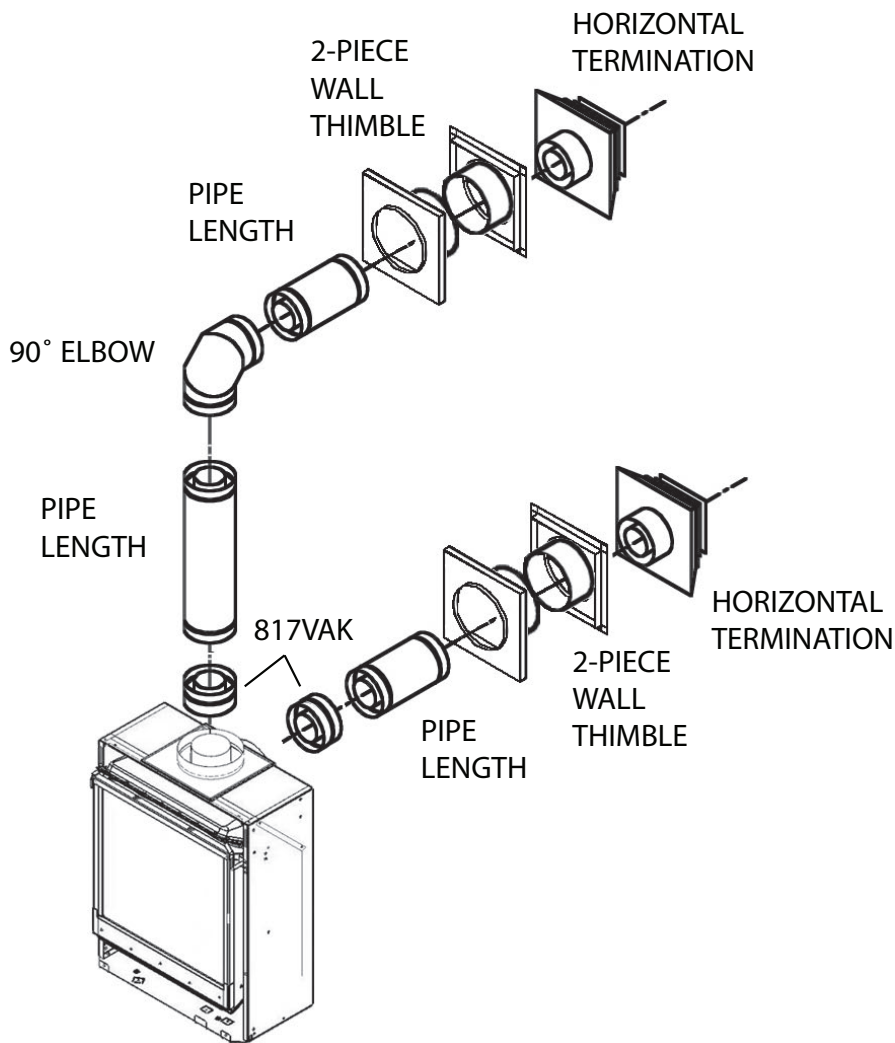

Co-Axial Venting

Rear Vent with No Vertical Rise

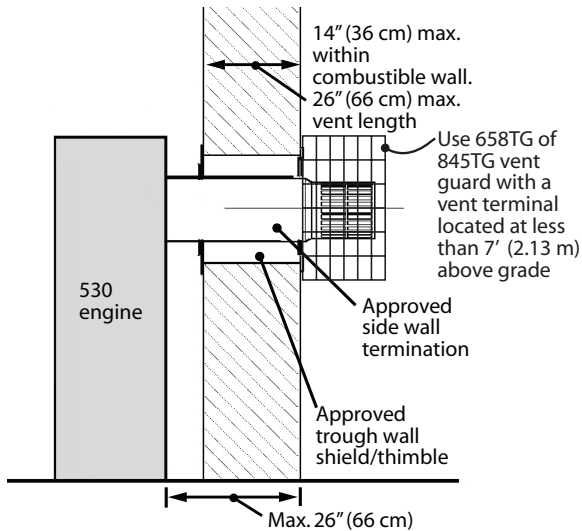

Rear vent—no vertical rise

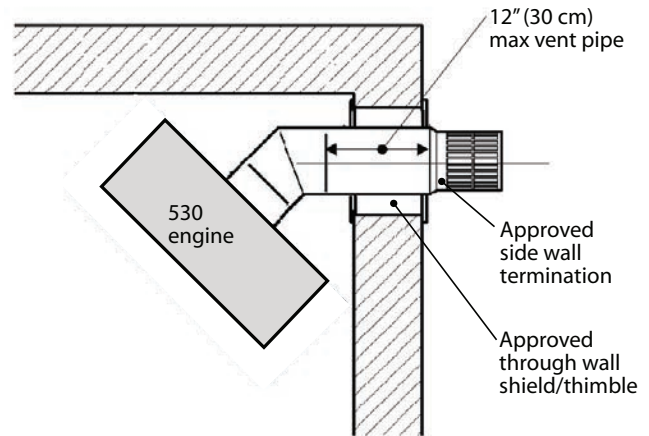

Corner rear vent—no vertical rise

Important Installer Notice – Weather Sealing & Vapor Barriers

It is the installer's responsibility to ensure that vent installations through exterior walls are caulked and weatherproofed in such a manner as to:

- Prevent rain water from entering the wall from the weather side by adequately caulking the outer vent plate to the exterior wall surface.
- Prevent moisture inside the home from penetrating into the wall structure by ensuring the inside wall plate is adequately sealed to the inside vapor barrier.
- Prevent rain water and moisture from entering the walls by sealing the joints between the outer vent tube and the inner and outer wall plates.

We recommend the use of a high quality polyurethane sealant.

Co-Axial Venting

Horizontal Vent Termination Location

- The vent terminal must be located on an outside wall or through the roof.
- This direct vent appliance is designed to operate when an undisturbed airflow hits the outside vent terminal from any direction.
- The minimum clearances from this terminal that must be maintained when located on an outside wall are shown in figure below. Any reduction in these clearances could result in a disruption of the

airflow or a safety hazard. Local codes or regulations may require greater clearances.

- The vent terminal must not be recessed into a wall or siding.
- The vent terminal should be positioned where any snowdrifts will not cover it.
- Sidewall vent terminations require a terminal guard such as 658TG or 845TG when accessible—within 7' of ground.

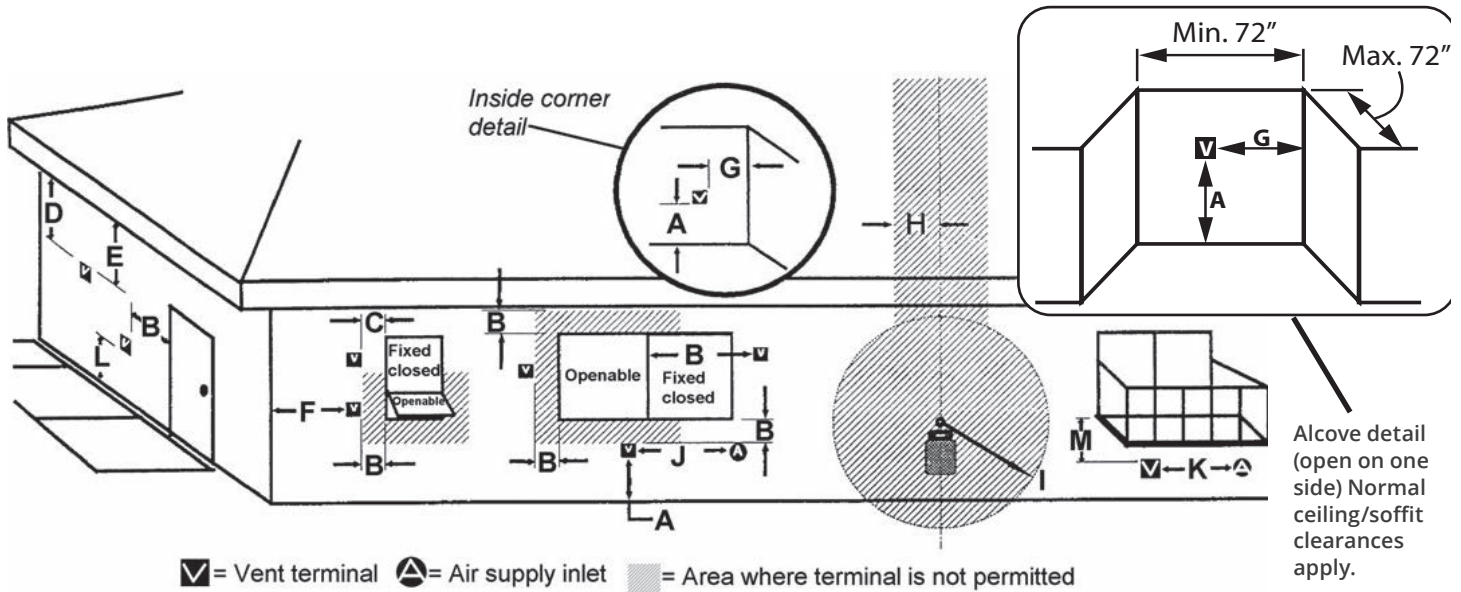

KEY	VENT TERMINAL LOCATIONS - MINIMUM DISTANCES Measured from the center of vent	MINIMUM CLEARANCE	
		Inches	Cm
A	Clearance above grade, verandah, porch, deck or balcony	12	30
B	Clearance to window or door that may be opened	12	30
C	Clearance to permanently closed window (recommended to prevent condensation on window)	12	30
D	Vertical clearance to ventilated soffit located above the terminal within a horizontal distance of 2 feet (60 cm) from the center-line of the terminal	18	46
E	Clearance to unventilated soffit	12	30
F	Clearance to outside corner	12	30
G	Clearance to inside corner	12	30
H	Horizontal clearance to center-line of meter/regulator assembly located within 15 feet (4.6 m) below the terminal	36	90
I	Clearance to service regulator vent outlet	36	90
J	Clearance to non-mechanical air supply inlet to the building or the combustion air inlet to any other appliance	12	30
K	Clearance to a mechanical air supply inlet	72	180
L	Clearance above paved sidewalk or a paved driveway located on public property Note: A vent must not terminate directly above a sidewalk or paved driveway, which is located between two single-family dwellings and serves both dwellings. THIS DOES NOT APPLY to direct vent, non-condensing appliances in the Province of Ontario.	84	210
M	Clearance under a verandah, porch, deck or balcony <i>Only permitted if veranda, porch, deck or balcony is fully open on a minimum of 2 sides beneath the floor</i>	12	30

Note: Local codes and regulations may require different clearances.

Co-Axial Venting

Co-Axial Venting Configurations with Vertical Rise

**4 x 90° ELBOWS MAXIMUM
(or equivalent)**

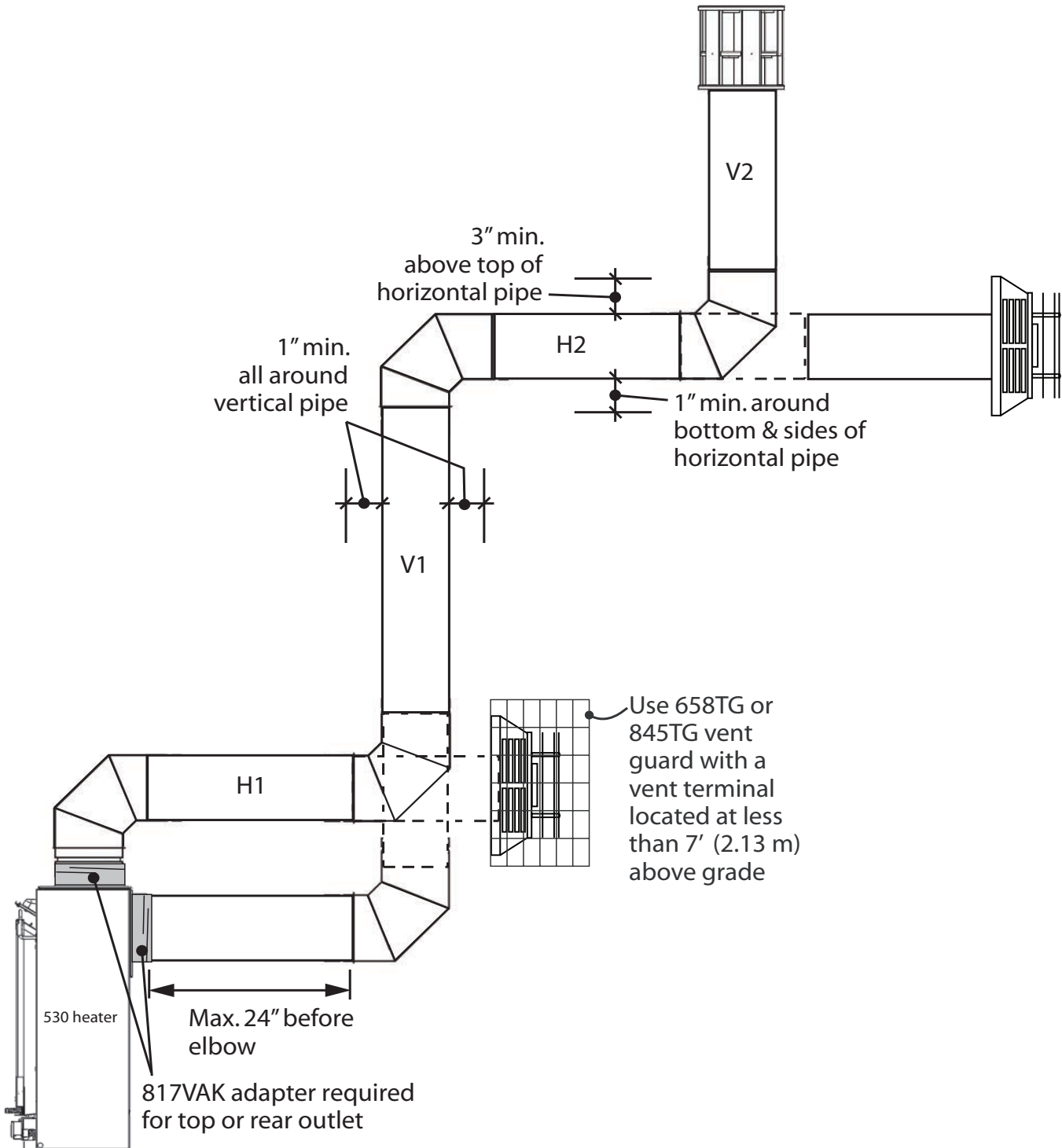

Example 1

V Value = V1 (6') + V2 (4') = 10'

H Value = H1 (2') + H2 (1') = 3'

Co-Axial Venting

How to Read the Venting Chart

The chart below applies to co-axial roof or wall termination in installations with vertical rise. See page 23 for installations with no vertical rise.

1. The total length of the vent pipe cannot exceed 40 feet (12.2 m).
2. The minimum vertical height with roof termination is 8 feet (2.44 m).
3. Any combination of rise and run can be used as long as they are within the allowable limits shown on the chart below.
4. A maximum of 4 x 90 degrees elbows—or equivalent (2 x 45 degrees = 90 degrees)—can be used.
5. Each 90 degrees elbow installed on the horizontal plane is equivalent to a 3 feet horizontal pipe; therefore, 3 feet must be subtracted from allowable horizontal run. (45 degrees elbow is equivalent to 18 inches horizontal pipe.)
6. All horizontal pipe runs must be graded 1/4 inch per foot upwards in the direction of the exhaust flow. The final pipe length, when terminating through the wall may be graded downwards slightly to prevent water migration.
7. Maximum co-linear venting is 40 feet (12.2 m).
8. A restrictor is required for all installations—see *Installation* section for more information.

Venting Chart—Allowable Co-Axial Vent Configurations with Vertical Rise

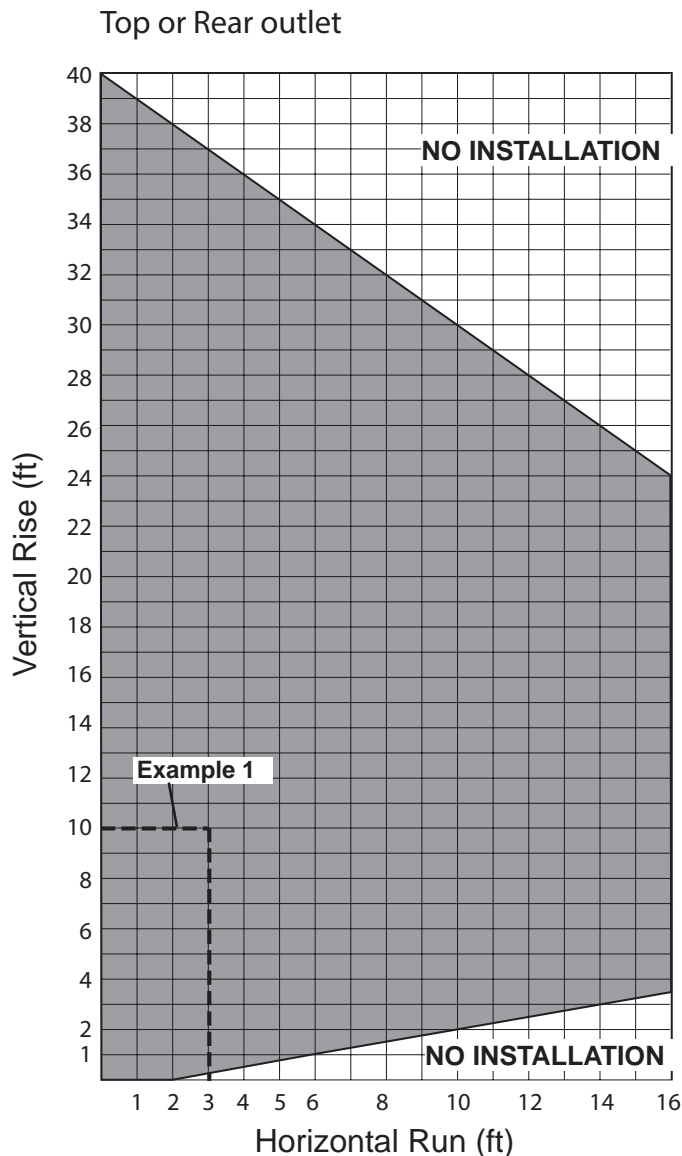

Example 1
V Value = V1 (6') + V2 (4') = 10'
H Value = H1 (2') + H2 (1') = 3'

Attaching Air Restrictors—Appliances with Vertical Vent Rise Only

No restrictors are required for appliances which only have a horizontal vent run. If installing an appliance which has a rear vent outlet connection and no vertical vent pipe rise, ignore this stage.

Two restrictor sets, like the one shown right, are supplied with each 530 engine unit. The restrictors cover part of the **inlet air openings** in the firebox **rear wall** on each side of the brick support. **Do NOT install the restrictors in the roof of the firebox!** Each set is assembled with an adjustable piece which can be moved to different positions depending of the vent configuration. See the table below to find out which position is optimal for each type of installation.

- To fit the restrictors, loosen the two center screws of the left and right inlet ports. Place the restrictor assembly under the screw heads and tighten the center screws.
- To set the adjustable restrictor piece, loosen the two screws, position the adjustable piece according to the diagram below and tighten the screws.

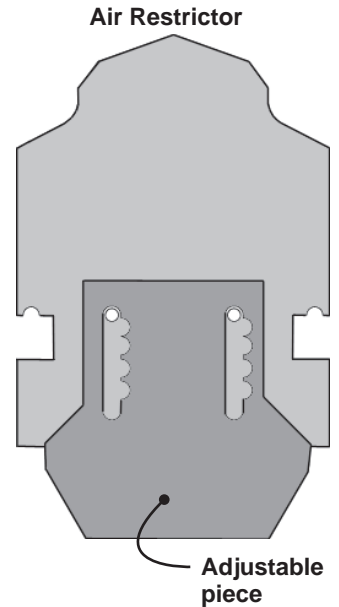

Vent terminal	Vertical vent pipe run	Use restrictor setting	
		Logs/Rocks	Coals
Horizontal through wall (WITH vertical rise)	Less than 4 ft (122 cm)		
	More than 4 ft (122 cm)		
Vertical through roof			

Note: NO restrictors required with straight out rear venting

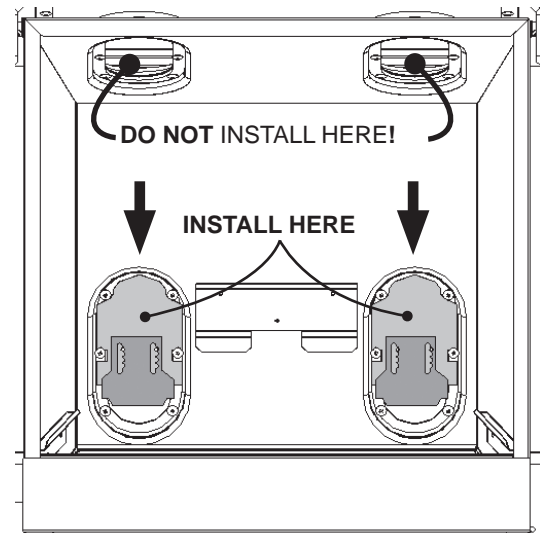

Install restrictors in the **inlet air openings in the firebox rear wall** behind the rear log support.

Co-Axial Venting

Co-Axial Vertical Installations

- Check the roof pitch to determine which roof flashing will be needed. See venting accessories list on page 47 for allowable components.
- The distance from the roof to the lowest terminal discharge opening (“H” in figure) depends on the roof pitch and must be in accordance with the manufacturer’s instructions supplied with the termination unit.

*Note: The venting system for these appliances is considered to be a **Special Venting System**. The rule in the Installation Code requiring a minimum vent height of 2 feet above any portion of a building within 10 feet does not therefore apply.*

- The minimum clearances to combustible materials all round the vent pipes must be in accordance with the dimensions shown in the previous pages of this manual.
- Drop a plumb from the ceiling to the center of the appliance vent opening. Mark the position on the ceiling. Drill a small hole at the marked position.
- Determine the position where the vent will pass through the roof. If directly above the position where it penetrates the ceiling, drop a plumb from the roof to the small hole in the ceiling and mark the roof at this spot.

If rafters or other obstructions will prevent a vertical exit or if clear attic space is desired, the roof outlet can be offset using 45 degree elbows.

Drill a small hole at the marked position.

- A ceiling firestop must be installed at the second floor and higher floors. A ceiling support should be used below the flat ceiling.

To install the firestop and support, cut and frame a 10 inches (254 mm) square hole centered on the small hole previously drilled.

- Fit vent accessory elbows and pipe lengths as required up through ceiling support boxes and firestops. If installation includes offset, support the offsetting pipes every 3 feet (1 m) with wall straps as shown.
- Cut a hole in the roof centered on the small hole. The hole must allow for the minimum clearances to combustible materials. See *Venting* section in this manual.

- Fit pipe lengths through the roof. Fit roof flashing securing it with roofing nails.
- Fit storm collar and termination cap.
- FS installations. Secure the appliance to the floor or wall if necessary.

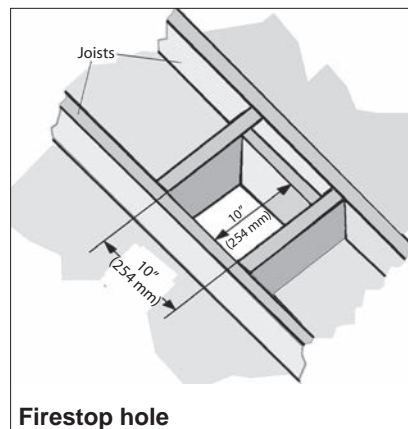
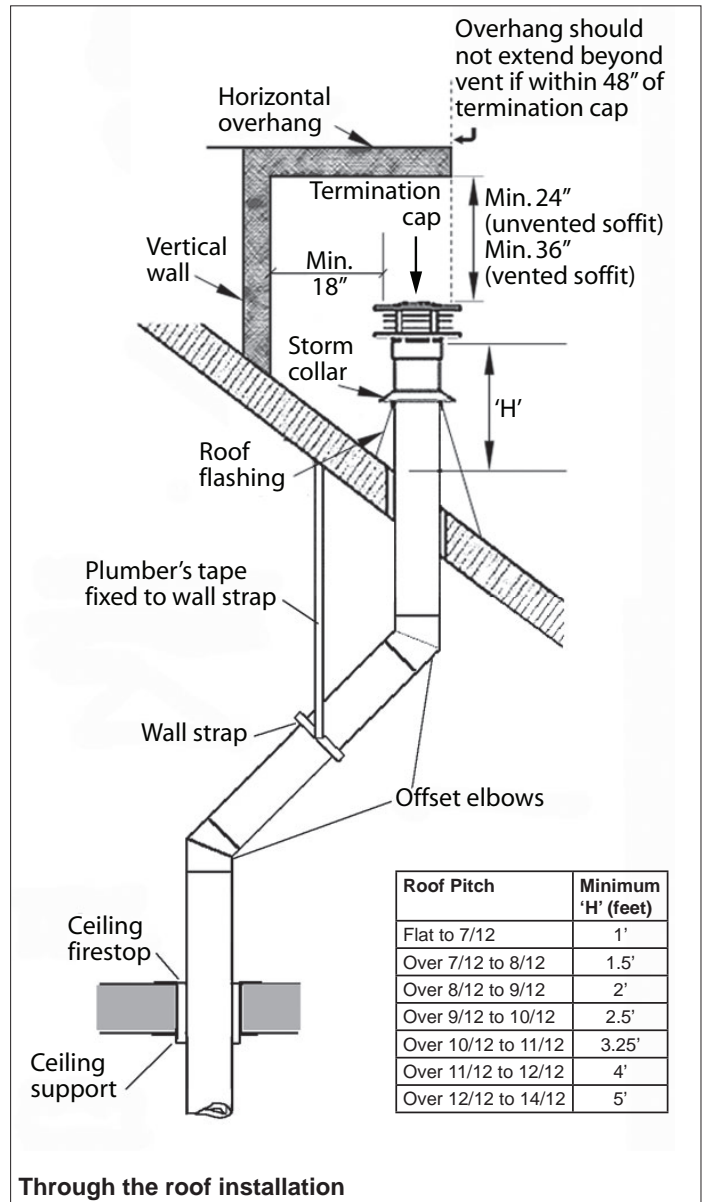

Co-Linear Venting

Co-linear Venting into Existing Solid-Fuel Burning Fireplaces and Chimneys

See venting accessories list starting on page 46 for allowable components.

Co-linear adapter may be installed as top or rear outlet—see page 32.

- Co-linear and co-axial venting may be combined in a single venting system provided conversion is done only once using approved components and maintaining proper clearances;
- Three-inch liners may only be installed into solid-fuel burning fireplaces and chimney systems (no combustible construction);
- The appliance must not be connected to a chimney flue serving a separate solid-fuel burning appliance.
- Restrictors not required for co-linear sidewall venting with less than 5'-0" vertical rise. For restrictor settings beyond 5'-0" refer to chart on page 27.

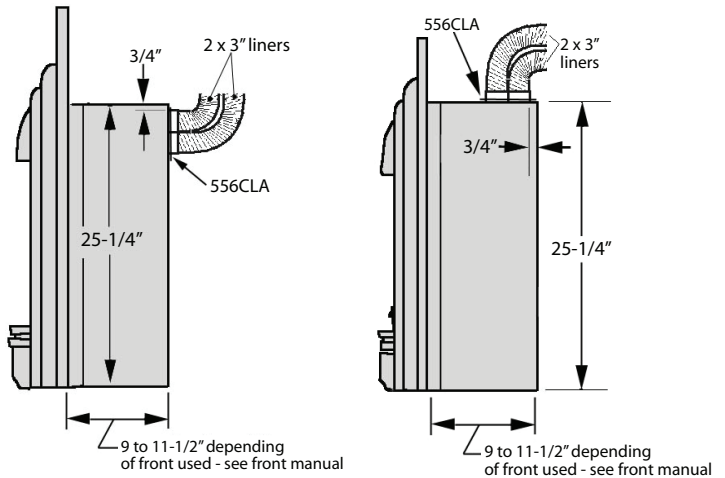

556CLA Rear Mounted

556CLA Top Mounted

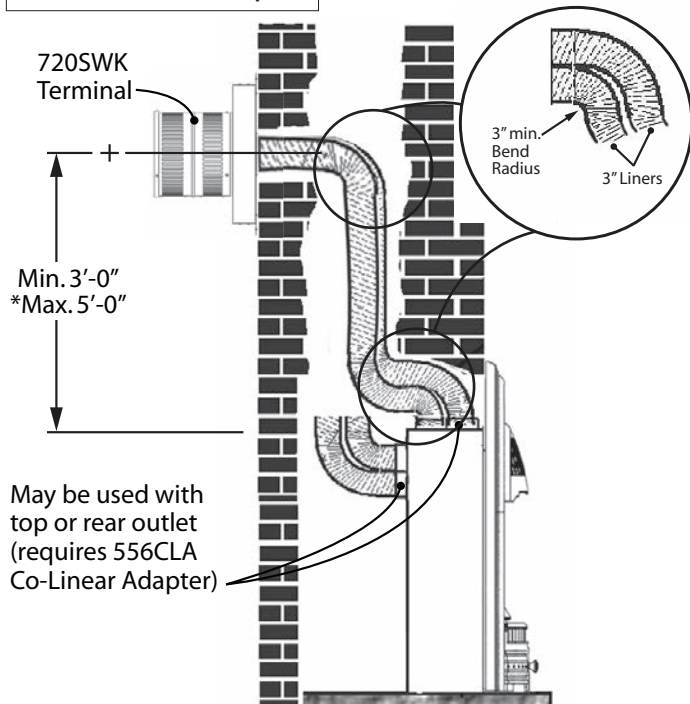
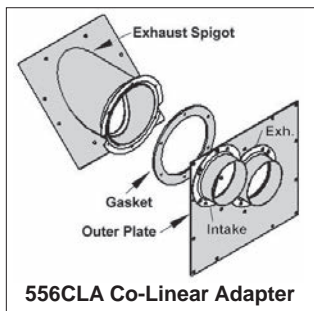

* May be extended beyond 5'-0". Refer to the 720SWK installation instructions

Sidewall co-linear installation into existing F/P using 720SWK—for units with logs, rocks or driftwood only

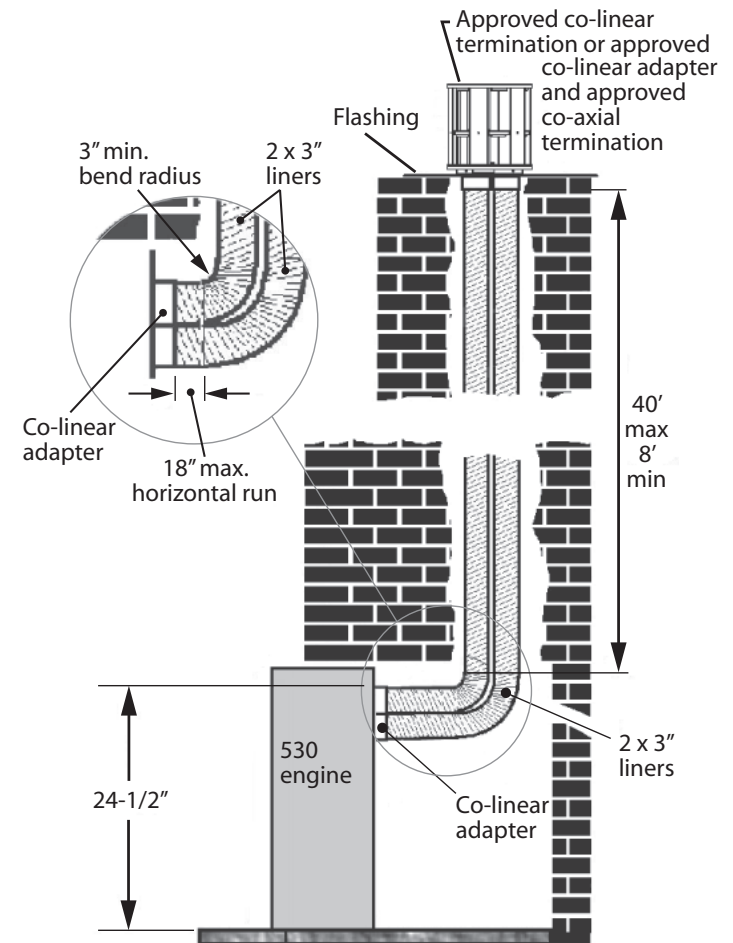

Vertical co-linear installation into existing F/P

Co-Linear Venting

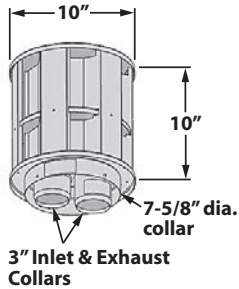

559CLT Co-Linear Vertical Terminal

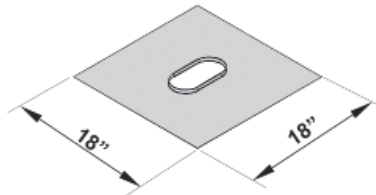

559FSK Flashing Kit

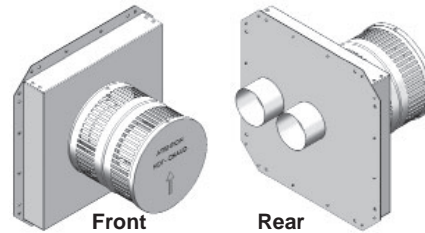

**720SWK Sidewall Horizontal Terminal
—for logs or rocks units only**

Alternate to 556CLA/559CLT/559FSK Conversion for vertical termination

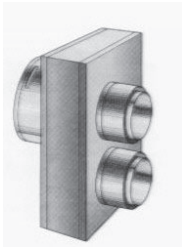

Co-Axial to Co-Linear Adapter

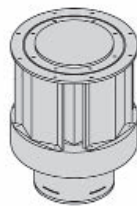

Terminal Cap

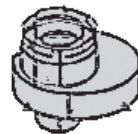

Co-Linear to Co-Axial Adapter

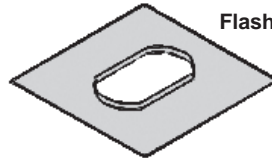

Flashing

Installation Planning

Installer—READ THIS FIRST

Only qualified licensed or trained personnel should install this appliance.

1. YOU NEED TO KNOW FROM THE HOMEOWNER:

- What type of installation - free standing / zero clearance (ZC) / insert;
- What front / stove is used with the engine;
- What is the required cavity size and hearth finish - see front / stove casing installation manuals;
- What are the thickness and type of wall finish around the firebox opening (ZC)
- What are the optional accessories to be installed with this fireplace if any;
- What is the venting configuration - top / rear / co-linear

2. Unpack the appliance, removing all items packed inside and around the appliance.
3. Check that you have everything, using the Pack Content sheet. Also check that you have the front / stove casing, ceramic walls and fuel bed, optional accessories.
4. Remove the window of the appliance.

5. Convert the vent outlet if necessary.
6. Place the appliance in final position.
7. Install the venting system and tape vent pipe joints.
8. Position the restrictors.
9. Connect the electrical wiring for optional electric accessories if used.
10. Install the optional electric accessories if used.
11. Connect and test the gas supply.
12. Install the liners.
13. Install the fuel bed.
14. Refit the window and the hot glass safety plate if removed.
15. Install the control wall switch kit.
16. Initialize the remote control system.
17. Verify the operation and adjust aeration settings.
18. Install the remote control handset wall holder.
- 19. Instruct the homeowner on the operation and maintenance of the fireplace.**
20. Finish the wall around the fireplace if necessary.
21. Install the front trim **and barrier screen.**

Installation

Unpack Appliance

Beware of sharp edges! Wear gloves!

1. Remove the cardboard wrapping and the wood pallet from the appliance and discard.
2. Unpack any loose items from around the appliance.
3. Remove the window and set aside in a safe place to avoid damage—see next page.
4. **Verify that you have all the components required for the installation, including:**
 - liners and fuel bed (in separate cartons);
 - front / stove casing with barrier screen;
 - venting components and accessories;
 - electrical components if installing optional blower.

Remove Window

1. Release the top of the window by pulling forward the two levers at the top corners.
2. Unscrew the two spring-loaded bolts securing the bottom of the window.
3. Carefully lift the window. Keep the window and bolts in a safe place.
4. Remove the packaged ceramic (Bricks/Logs/Coals/Rocks) from firebox.

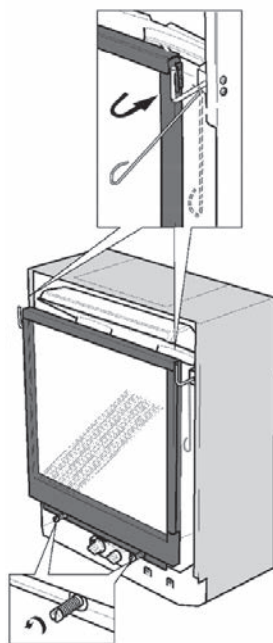

Remove Burner Module

It may be desirable to remove the burner module to gain access for gas fitting, to install a fan kit, or to fasten the unit to the floor or plinth supplied with the zero clearance fronts.

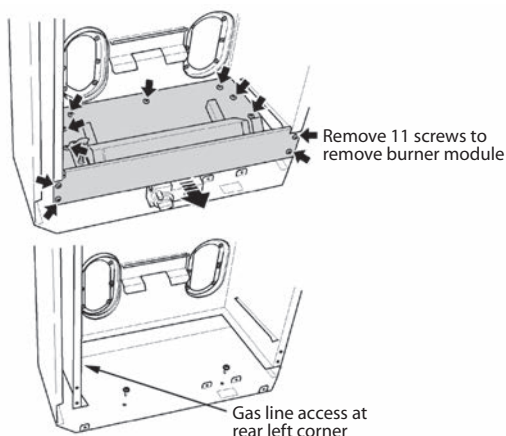

Convert from Rear Outlet to Top Outlet (co-axial venting)

If installing with rear vent outlet, go to next step.

1. Remove the top plate and seal by unscrewing 12 screws. Keep the seal, plate and screws for fitting to the back.
2. Remove the rear outer vent collar and seal by unscrewing 12 screws.
3. Remove the rear inner vent collar and seal by unscrewing 8 screws.

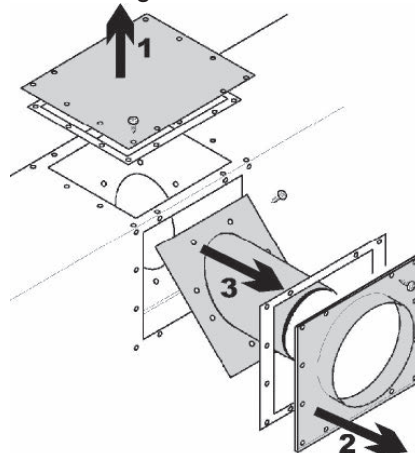

4. To make sure that the collars are axially aligned, fit the adapter 817VAK over the outer vent collar.
5. Position the inner collar and seal vertically inside the top of the appliance. Drop the outer collar with adapter over the inner collar to ensure alignment. Secure the inner collar with 8 screws and the outer collar with 12 screws.
6. Fit the plate and seal (which was previously removed from the top) to the back of the appliance with 12 screws.

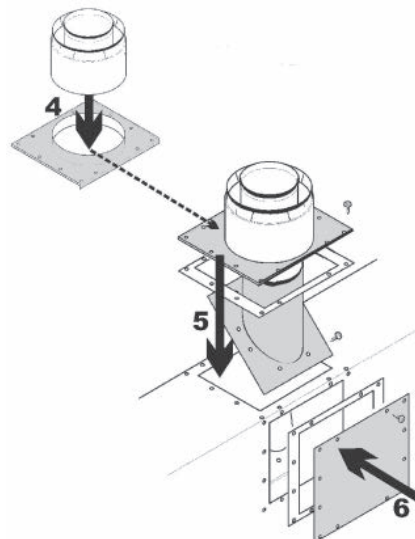

Installation

Prepare Vent Outlet

Co-axial Installations

1. Fit the adapter 817VAK over the appliance vent collars pushing on firmly. Align the adapter so that the seam on horizontal pipes is not at the bottom—check by temporarily fitting a pipe.
2. Drill through the adapter outer tube and appliance outer collar for #6 screws. *Make sure that the drill does not penetrate the inner tubes.*
3. Secure the adapter to the outer collar with two #6 thread cutting screws supplied.

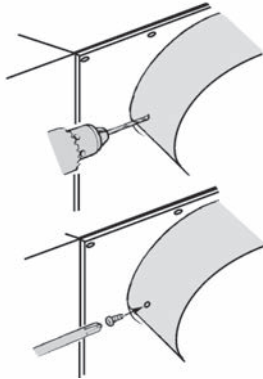

Co-linear Installations using Listed Generic Adapter Box

1. Fit the adapter 817VAK over the appliance vent collars pushing on firmly.
2. Fit and fully twist-lock the co-axial-to-co-linear adapter to the 817VAK adapter.
3. Keeping the connector and adapter fully twist-locked, rotate them so that the air inlet collar on the connector is at the bottom.
4. Drill through the adapter outer tube and appliance outer collar for no. 6 screws. *Make sure the drill does not penetrate the inner tubes.*
5. Secure the adapter to the outer collar with two no. 6 thread cutting screws supplied.

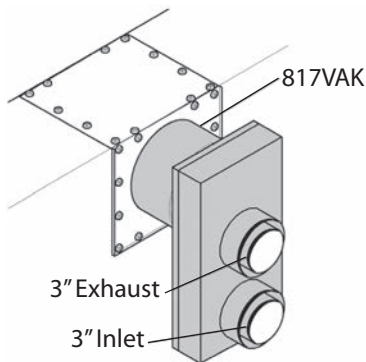

Co-linear Installations using Valor 556CLA Co-linear Adapter

(Note: Instructions may vary as 556CLA may be installed on Top or Back of Heater.)

1. Remove the blank plate and gasket to gain access to the exhaust spigot. Retain the plate and gasket for re-use later.
2. Remove the existing outer intake plate. Retain the gasket only for re-use.
3. Remove the existing exhaust spigot—the gasket below should remain on the heater.

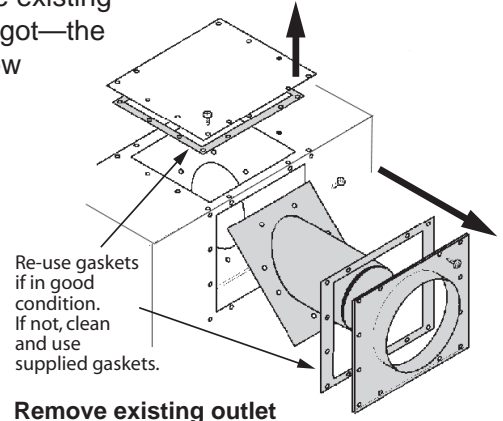

Remove existing outlet

4. Install the new co-linear exhaust spigot re-using existing screws. Ensure all screws are reinstalled tightly.
5. Install the new co-linear outer plate (note: up/down front/back orientation on drawing) re-using existing gasket and screws. Use 6 additional screws supplied to seal outer plate to gasketed flange of exhaust spigot. Connect the 3-inch diameter flex liners directly to outer plate collars using sheet metal screws.

Note: “exhaust” & “intake” must correspond with roof or wall termination.

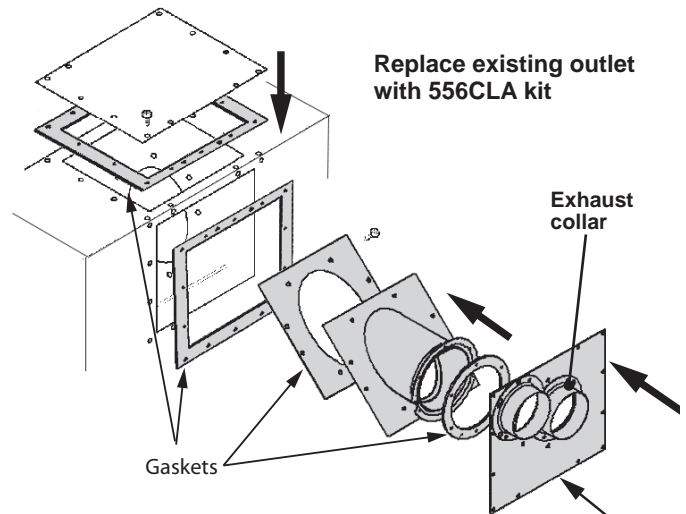

Replace existing outlet with 556CLA kit

This is the **bottom edge** when installing as rear outlet
This is the **front edge** when installing as top outlet

Connect Gas Supply

- It's preferable to rough-in the gas line at this point before proceeding with the firebox installation.
- The appliance is supplied for supply gas connection at the control valve. Supply line connection to the control valve of the appliance is 3/8 inch NPT (female).
Take care not to apply torque to the valve. An isolating valve may be fitted within the appliance case. Be aware that the supply pipe should follow routing to clear the remote receiver or optional fan.
- Use only new black iron or steel pipes, CSST, or copper tubing if acceptable—check local codes. *Note that in USA, copper tubing must be internally tinned for protection against sulfur compounds.*
- Unions in gas lines should be of ground joint type.
- The gas supply line must be sized and installed to provide a supply of gas sufficient to meet the maximum demand of the appliance without undue loss of pressure.
- Sealant used must be resistant to the action of all gas constituents including LP gas. Sealant should be applied lightly to male threads to ensure excess sealant does not enter gas lines.
- The supply line should include a **manual shut-off valve** and **union** to allow the appliance to be disconnected for servicing.
- Pressure test the supply line for leaks.
- **The appliance and its individual shut-off valve must be disconnected from the gas supply piping system during any pressure testing of that system at test pressures in excess of 1/2 psig (3.5kPa).**
- **The appliance must be isolated from the gas supply piping system by closing its individual manual shut-off valve during any pressure testing of the gas supply piping system at test pressures equal to or less than 1/2 psig (3.5kPa).**
- Failure to either disconnect or isolate the appliance during pressure testing may result in regulator or valve damage. Consult your dealer in this case.
- The minimum supply pressure is given in *Specifications* section of this manual.
- All piping and connections must be tested for leaks after installation or servicing. All leaks must be corrected immediately.

- When testing for leaks:
 - Make sure that the appliance is turned off.
 - Open the manual shut-off valve.
 - Test for leaks by applying a liquid detergent or soap solution to all joints. Bubbles forming indicate a gas leak. **Never use an open flame to check for leaks.**
 - Correct any leak detected immediately.
- The pressure test tapping locations are shown in figure below. A built-in non-adjustable regulator controls the burner manifold pressure. The correct pressure range is shown in the table in the *Specifications* section of this manual. The pressure check should be made with the burner alight and at its highest setting. See *Lighting Instructions* section for full operating details.

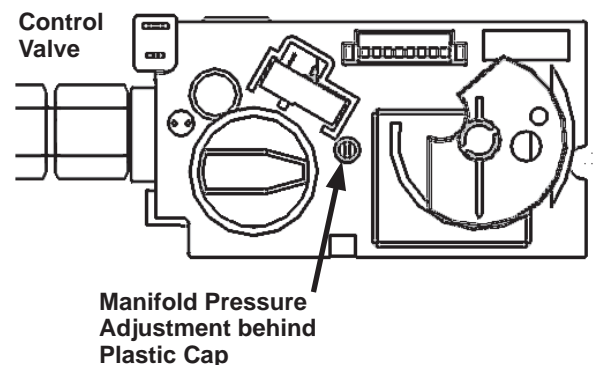
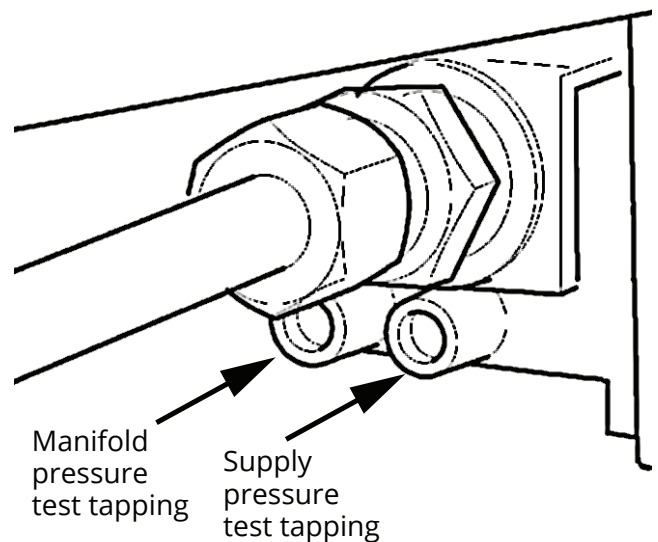

Install Ceramic Liners (Logs or Coals only)

The 530LSK and CSK fuel beds include a set of reversible liners. One side shows the brick pattern and the reverse side shows a black vertical fluted pattern. Follow the instructions below to install the liner set on the chosen side.

- **530RSK Rock Set liners.** For ceramic liners installation with the 530RSK, see *Install the 530RSK—Rock Set and Liners* section in this manual.
- **530DWK Driftwood Kit liners.** For ceramic liners installation with the 530DWK, see *Install the 530DWK—Driftwood Kit and Liners* section in this manual.
- **580RGL Reflective Glass Liner Set.** To install the 580RGL, see the installation instructions provided with the kit.
- **567FGP Top Grille.** At this point, you can install the 567FGP, if used (logs, rocks or driftwood versions only). The 567FGP Top Grille is sold separately except when included with front trim—see front trim installation manual.

1. Locate the ceramic rear wall in the channel at back of the firebox and flat against the back of the firebox.
2. Locate the sidewalls in the channels at the sides of the firebox.
3. Remove two screws from under the top front of the firebox. Using these screws fit the port cover.

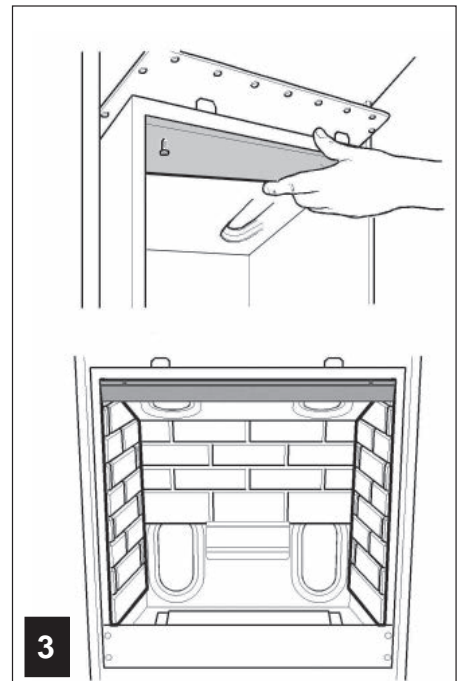
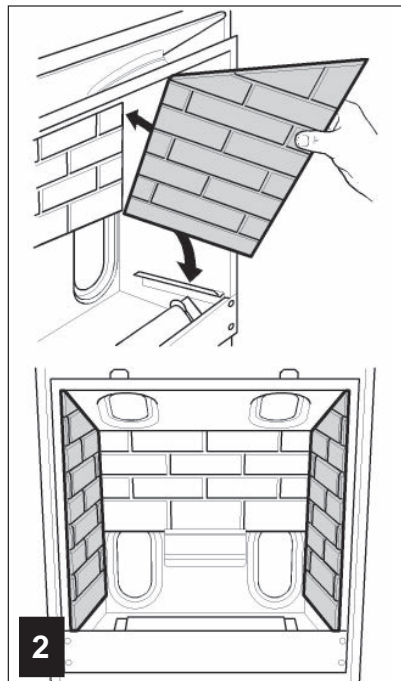
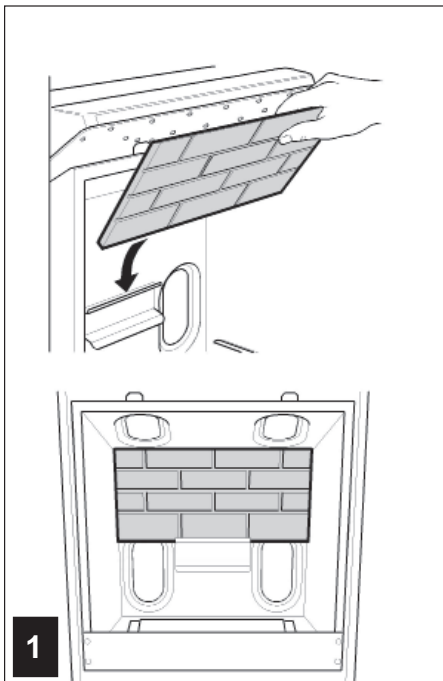

Installation

Install the 530LSK—Traditional Logs Set

1. Place the base log on the supports in the firebox and against the support at the firebox back.
2. Locate the rear upper log on the two ceramic pins at the rear of the base log.
3. Place the front log behind the metal strip at the front of the firebox.
4. Locate the right middle log on the pin in the right hand side of the base log .
5. Locate the left side log on the ceramic pin on the left hand side of the base log. Rest the narrow nose of this log on the projection at the front center of the base log—*ensure that the narrow nose does not rest on the burner.*
6. Locate the right side log on the pin in the front log and rest the nose of this log on the projection on the base log—*ensure that the nose does not rest on the burner.*

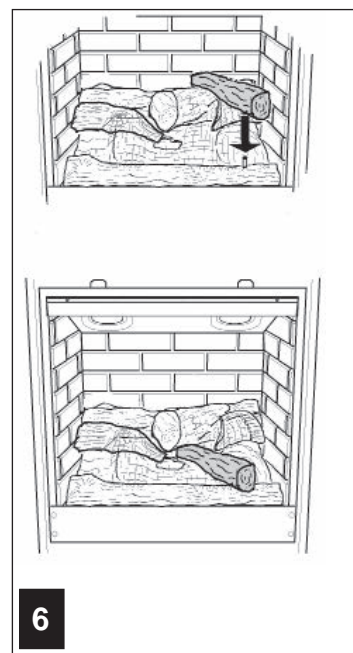
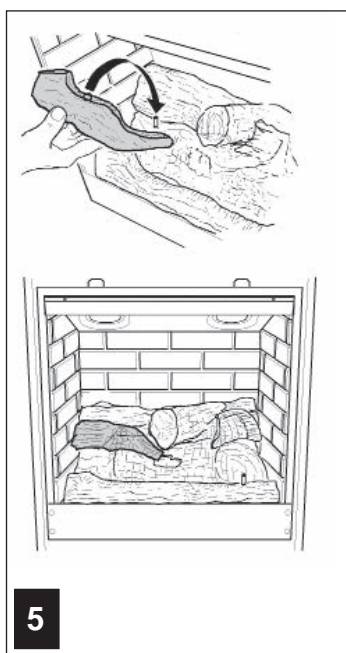
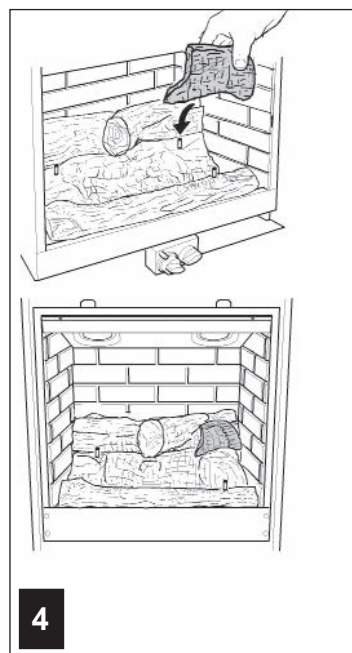
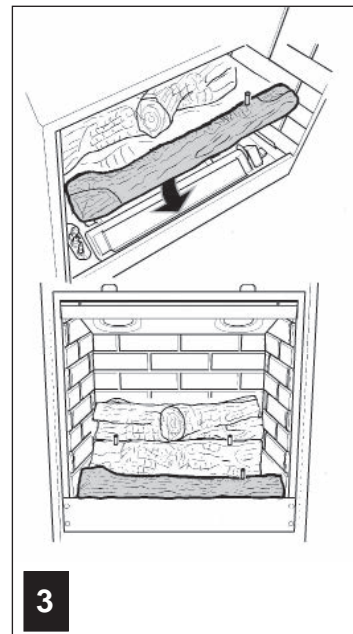
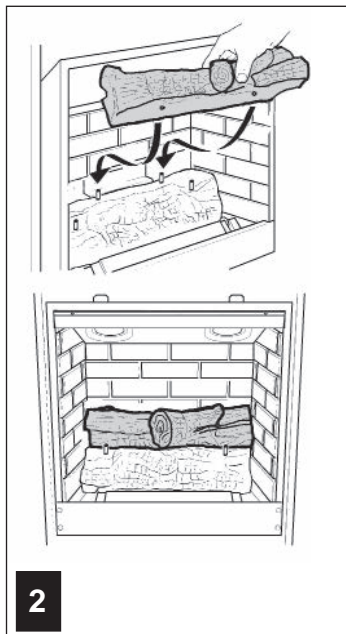
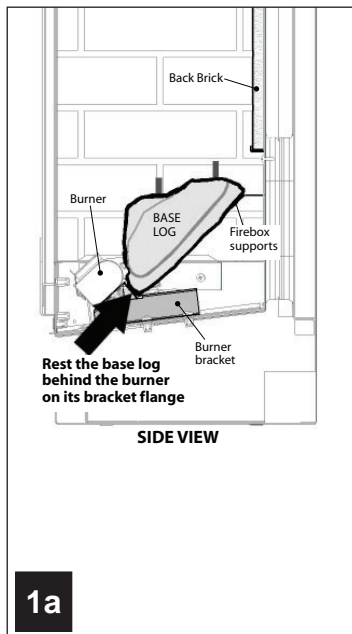
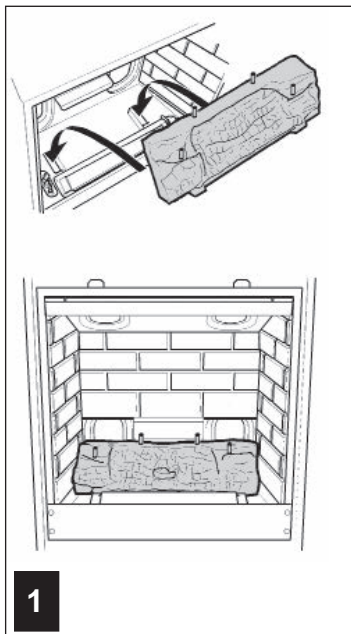

Installation

Install the 530CSK—Coal Set

1. Place the base coal on the supports in the firebox and against the firebox back.
2. Place the left front coal in position behind the metal lip at the front of the firebox. The side projection on this coal should be near the middle front of the firebox.
3. Place the right front coal behind the metal lip at the front of the firebox. Its left side should rest over the projection on the left front coal.
4. The center right coal has letter “R” embossed underneath. Place this coal behind the front right coal.
5. The center left coal has letter “L” embossed underneath. Place this coal behind the front left coal.

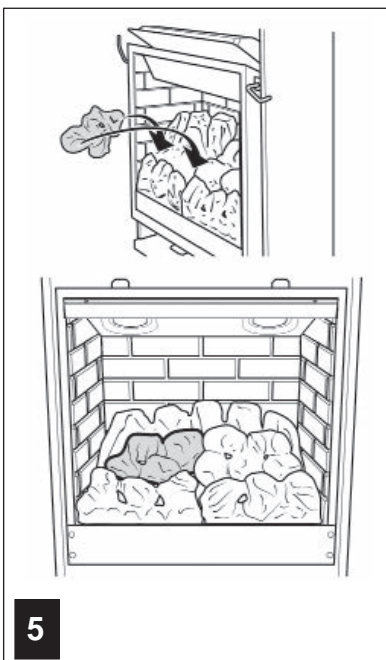
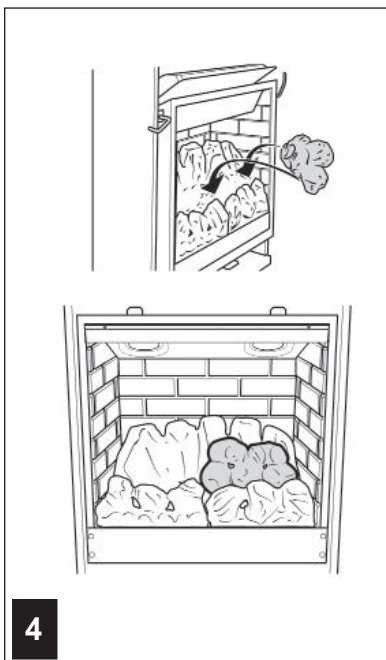
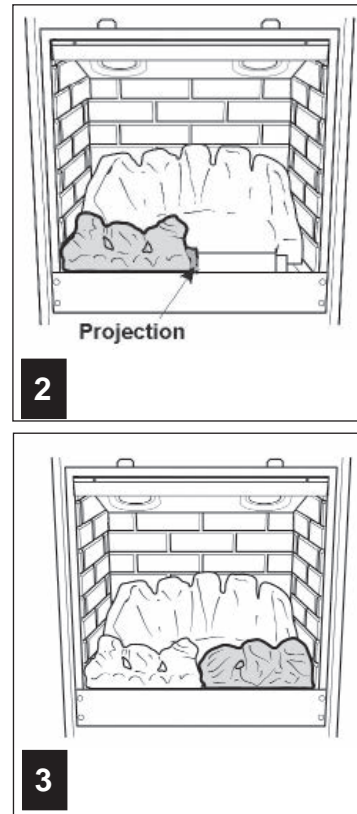
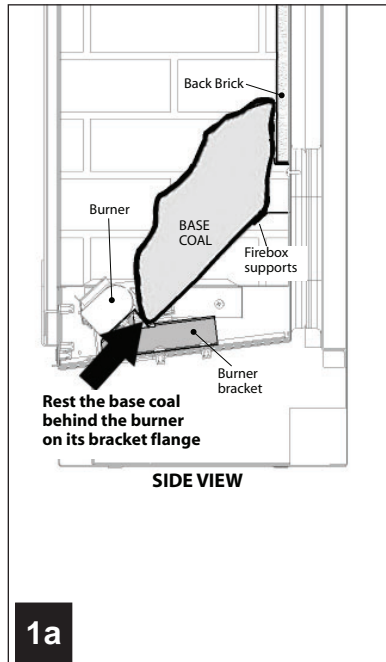
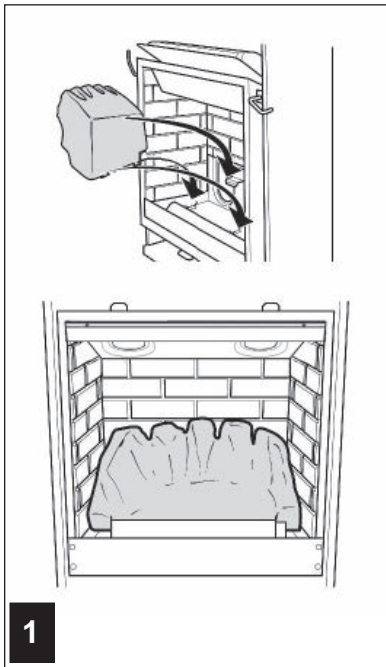

Installation

Install the 530RSK—Rock Set and Liners

Unpack each piece of the ceramic rock set carefully to avoid damages. The set contains:

- Ceramic platform
- Left and right side reversible ceramic panels
- Rear panel support
- Rear fluted panel
- Ceramic base for rocks
- 12 ceramic rocks

580RGL Reflective Glass Liner Set. To install the 580RGL, see the installation instructions provided with the kit.

Install liners

1. Remove the rear panel support inside the firebox (3 screws).
2. Replace with the rear panel support provided with the 530RSK kit and fix it (3 screws).

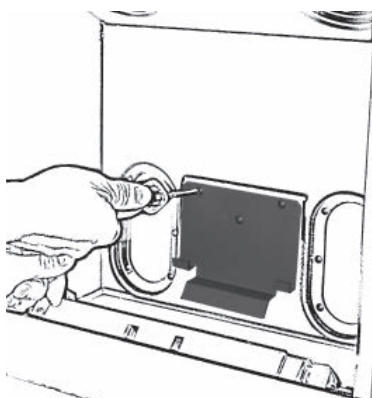

If installing the 567FGP Top Grille (sold separately), fit it now. See instructions supplied with the grille.

3. Place the rear panel on the rear support as indicated. Hold in place and go to next step.

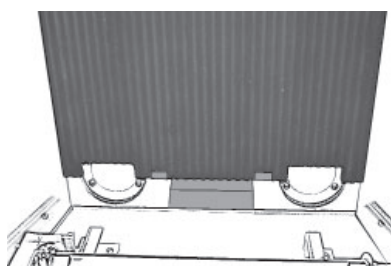

4. Place the left and then the right panels in the firebox showing the black fluted sides.

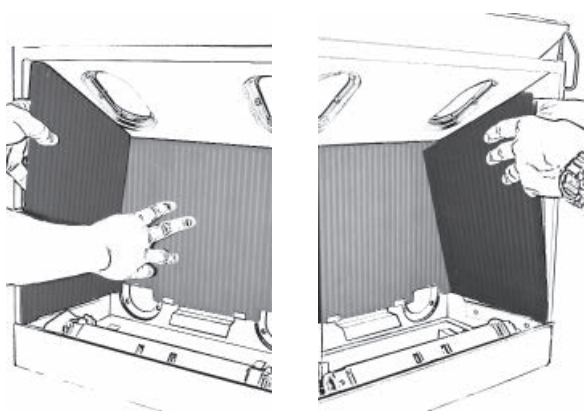

Install rock base & platform

1. Place the rock base behind the burner. The two protrusions in front of the base should rest on the burner mounts as indicated.

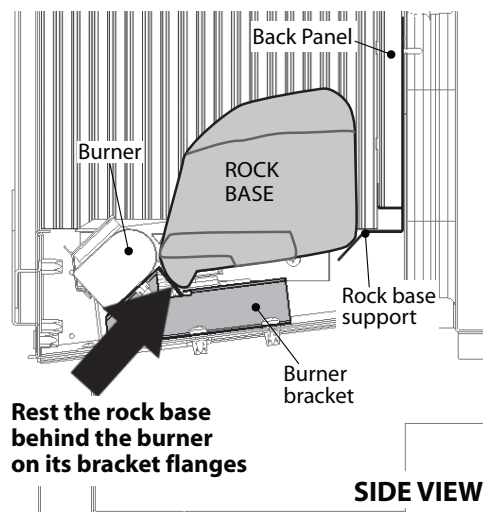
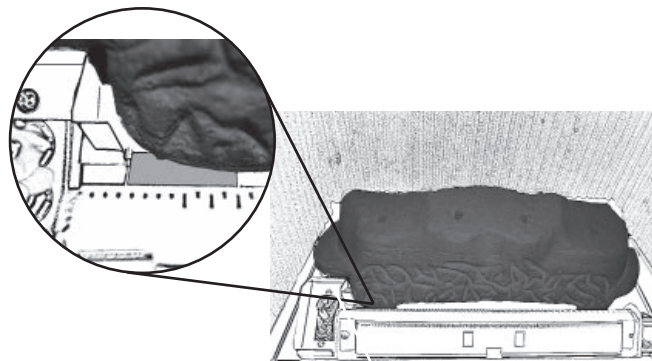

2. Place the ceramic platform over the burner and around the rock base with the pegs on the top. The rear part of the platform should overlap the edges of the rock base on each side.

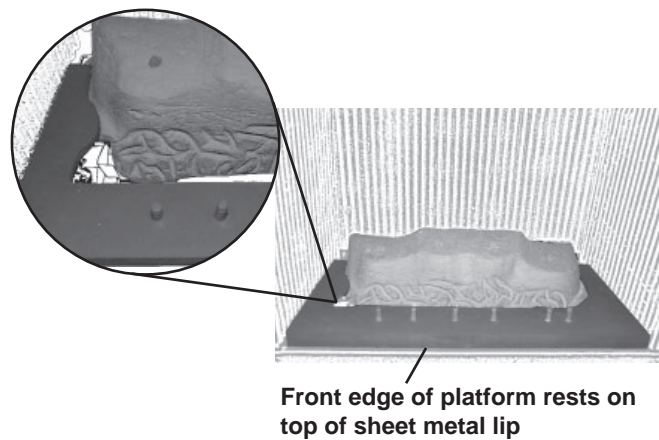

Installation

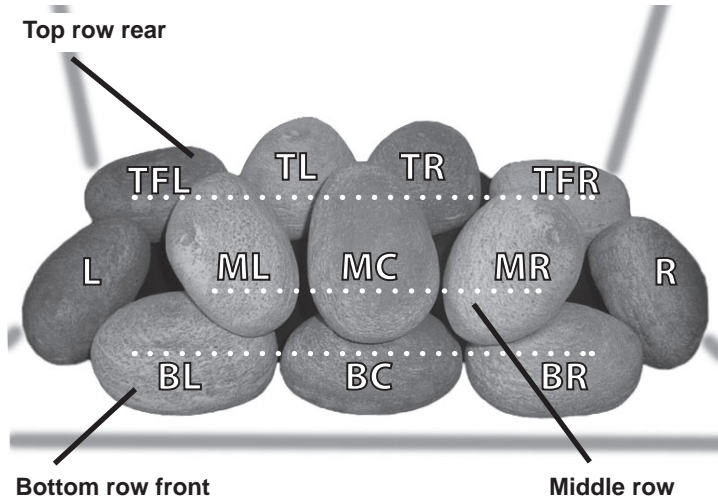

Install rocks

To get the optimal flame effect, it is important to place the rocks in their appropriate position. Each rock is embossed underneath with letters and an arrow indicating the position of the rock. **The arrows point to the front of the fireplace when the rock is installed.** See the image and table at the top of the page to help you with the identification and position of the rocks.

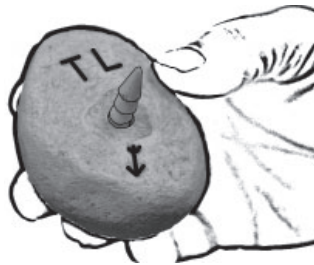

1. Identify the rocks **TFL, TL, TR, and TFR**. These rocks have pegs that fit in the holes on the top of the rock base. Install these rocks positioning them so that the arrow embossed underneath point to the front of the fireplace.
2. Identify the rocks **BL, BC, and BR**. These rocks have two holes that fit on the pegs of the ceramic platform. Install these rocks positioning them so that the arrow embossed underneath point to the front of the fireplace.

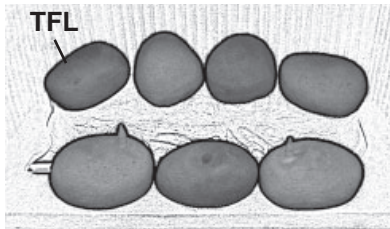
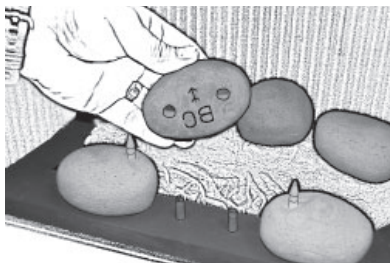

The edge of the platform is visible under the rock

Rock ID	Description	Other markers	Position in the firebox
TFL	Top far left	1 peg under	Top row rear
TL	Top left	1 peg under	Top row rear
TR	Top right	1 peg under	Top row rear
TFR	Top far right	1 peg under	Top row rear
BL	Bottom left	2 holes under, 1 peg above	Bottom row front
BC	Bottom center	2 holes under, 1 hole above	Bottom row front
BR	Bottom right	2 holes under, 1 peg above	Bottom row front
ML	Middle left	1 hole under	Middle row
MC	Middle center	1 peg under	Middle row
MR	Middle right	1 hole under	Middle row
L	Left	—	Left side
R	Right	—	Right side

3. Identify the rocks **ML, MC, and MR**. Those rocks have pegs that fits in the holes on the top of the rocks on the front row. Install those rocks positioning them so that the arrows underneath point to the front of the fireplace.

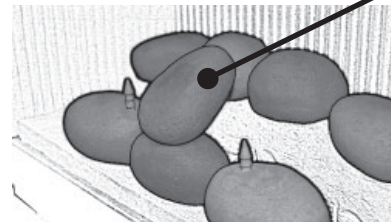
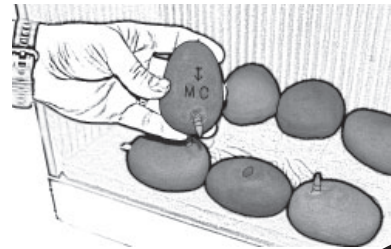

This rock is suspended and does not rest on the rocks of the row behind it.

4. Identify the rocks **L and R**. Those rocks don't have any peg or hole. Install those rocks as indicated, at the left and right of the rock pile positioning them so that the arrows underneath point to the front of the fireplace. The rock rests against the other rocks and is at an angled position. *Make sure that the TFL rock at the rear left is in the proper angle*—see image in step 2. See the image at the top of the page. You must be able to see the edge of the platform under the L rock (at left) as indicated below.

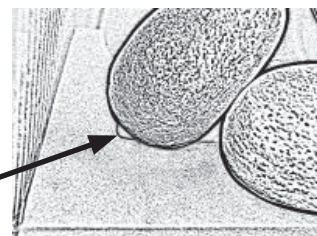

Installation

Install the 530DWK—Driftwood Kit and Liners

Unpack each piece of the ceramic driftwood set carefully to avoid damages. The set contains:

- Metal platform
- Left and right side reversible ceramic panels
- Rear panel support
- Rear fluted panel
- 5 driftwood logs
- 4 ceramic pebbles

580RGL Reflective Glass Liner Set. To install the 580RGL, see the installation instructions provided with the kit.

Install liners

1. Remove the rear panel support inside the firebox (3 screws).

2. Replace with the rear panel support provided with the 530DWK kit and fix it (3 screws).

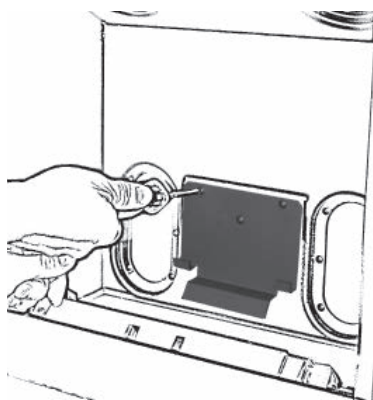

If installing the 567FGP Top Grille (sold separately), fit it now. See instructions supplied with the grille.

3. Place the rear panel on the rear support as indicated. Hold in place and go to next step.

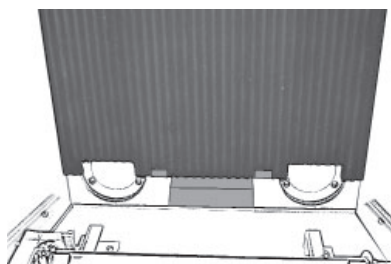

4. Place the left and then the right panels in the firebox showing the black fluted sides.

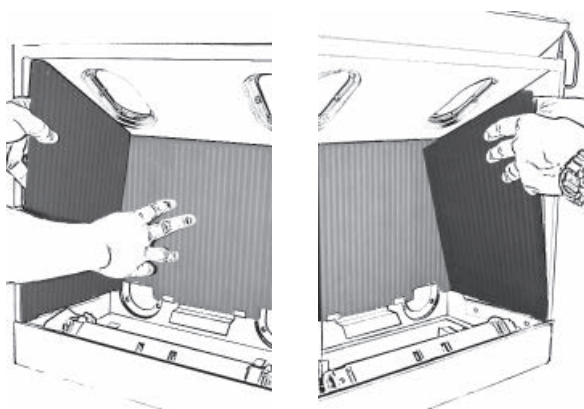

Install platform, driftwood logs and pebbles

1. Place the protrusion at the back of the base log on the ledge of the rear panel support as far back as it will go. Then pull the log evenly towards the front until it rests against the burner supports.

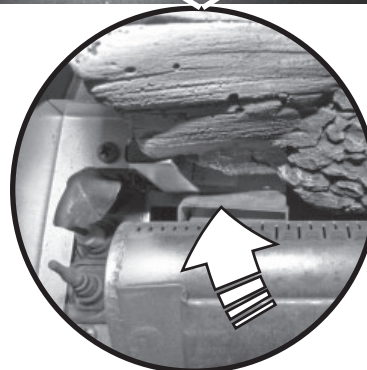
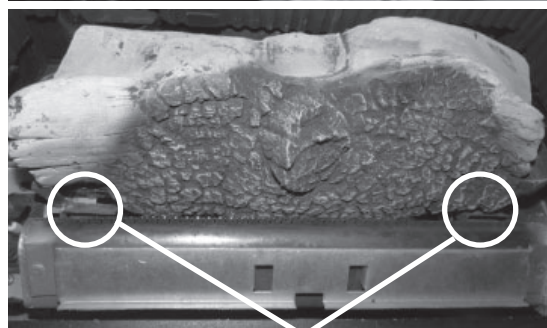
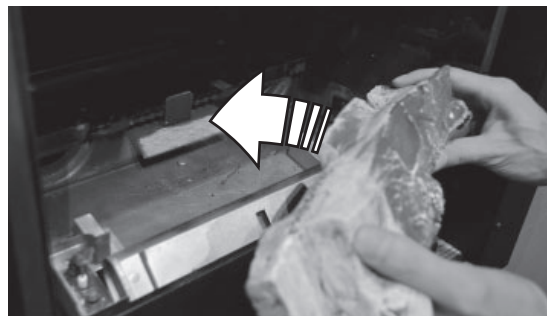

2. Place the metal platform and centre it over the burner and around the base log with the pegs on the top. The front of the platform must rest on the edge of the firebox. The right end rests of the base log.



Installation

3. Place the rear log on top of the base log locating it into the notches on top of the base log.

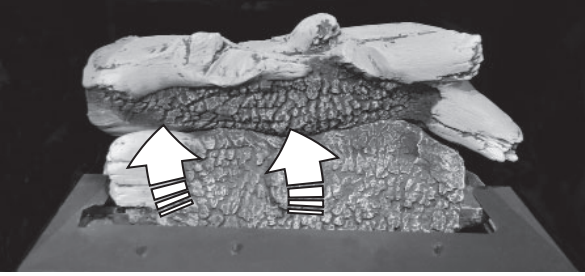

4. Place the centre log on the platform inserting the peg into the hole on the log as indicated. Line up the log parallel to the platform.

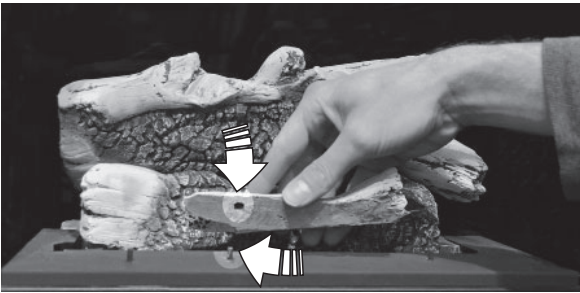

5. Place the right log inserting the platform peg into the hole at the end of the log; rest the upper end of the log in the notch on the rear log as indicated.

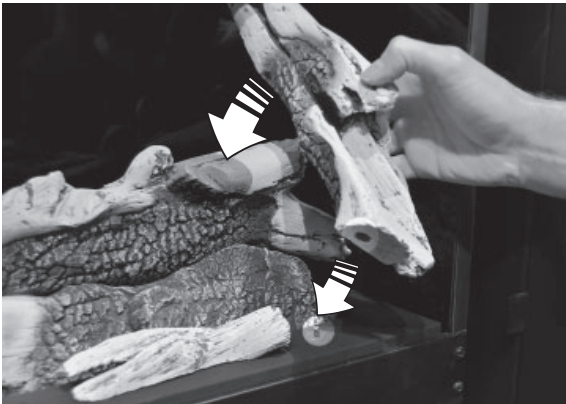

6. Place the left log inserting the platform peg into the hole at the end of the log; rest the upper end of the log in the notch on the rear log as indicated.

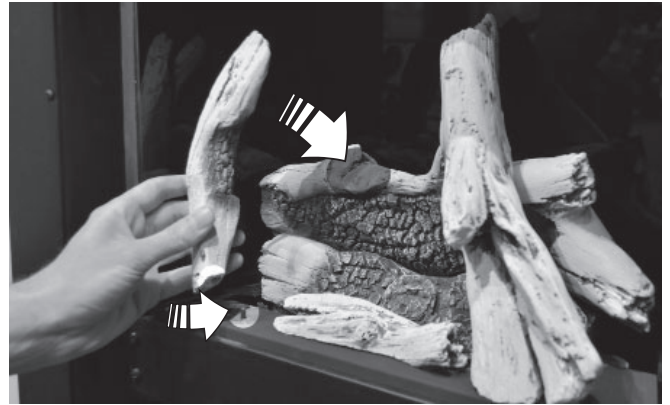

7. Place one larger pebble on each end of the platform to cover its edge as indicated; place the smaller pebbles on the platform in front the larger ones as indicated.



Installation

Refit and Check Window

1. Place the window centrally against the engine unit and resting on the support at bottom front of the engine.
2. Pull the clamping bars forward and rotate inwards to secure the top of the window.
3. Fit the two spring loaded bolts through the bottom of the window and tighten to secure the bottom of the window.
4. Pull the top and bottom of the window forward and release to ensure the springs return in position.

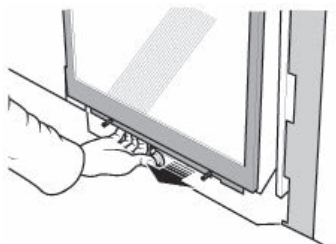
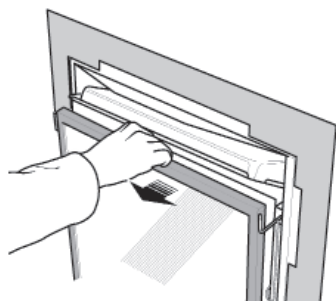
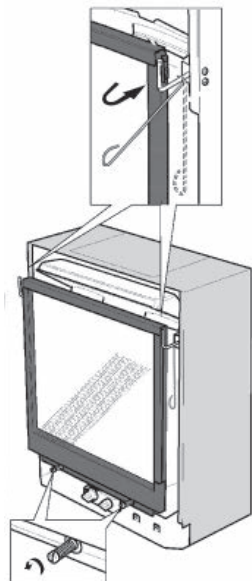

5. Apply firm hand pressure around the window frame to ensure the window is sealed tight against the firebox.
6. **If the Hot Glass Warning plate has been removed from the front lower corner of the window, reinstall it by sliding it between the glass and the frame as indicated.**

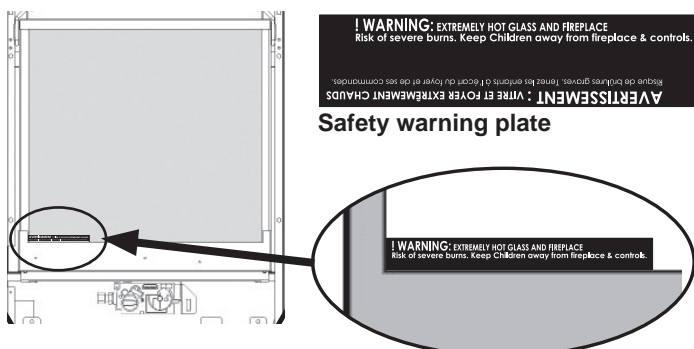

! DANGER

The window unit must be correctly installed, fastened and sealed after servicing or serious bodily injury and/or damage to the appliance may result.

To ensure a safe operation:

- Double-check that the window frame is correctly installed;
- Verify that the levers are hooked properly to the window tabs then;
- Pull out the top of the window and release it to insure the springs return it;
- Ensure the window is sealed before operation.

! WARNING

Failure to install the window correctly can leak carbon monoxide, affect the performance of the fireplace, damage components, cause overheating resulting in dangerous conditions. Damage caused by incorrect window installation is not covered by the Valor warranty.

Installation

Install Battery Holder

The batteries that power the receiver and handset need to be installed prior to synchronization and use.

1. Take the receiver out from under the firebox.
2. The battery holder and cable are supplied with the appliance. Insert 4 x 1.5 V high quality alkaline batteries in the battery holder and 1 9V battery in the remote handset.



3. Connect the cable to the receiver.

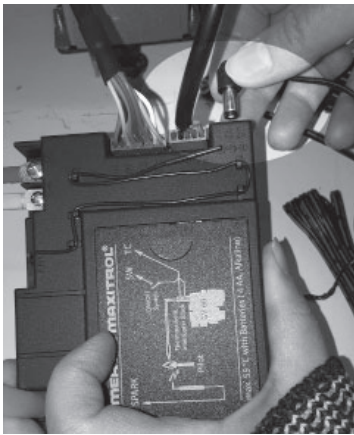

4. Connect the other end of the cable to the battery holder.

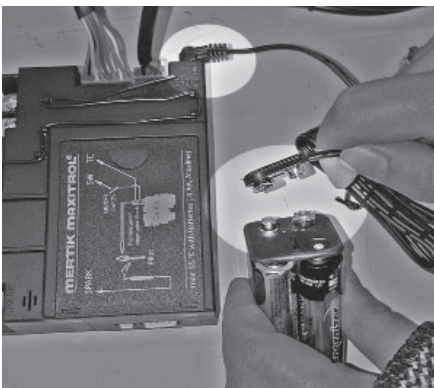

5. Place the receiver and battery holder as shown below (placement may vary with installed options).

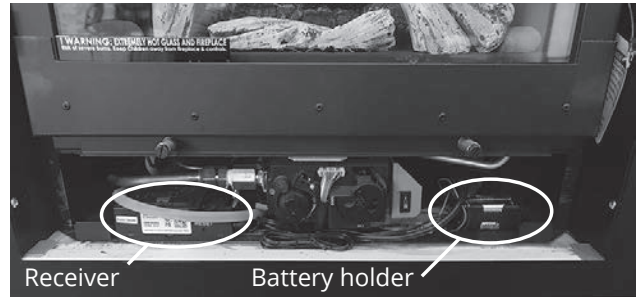

6. Use a heat resistant tie to gather any extra cable between the receiver and the holder.

CAUTION

DO NOT let the cable touch the burner plate above, it will melt during operation.

Synchronize Remote Control

The receiver and the handset of the remote control system must be initially synchronized before the first use.

1. With a thin object, press and hold the receiver's reset button until you hear one short and one long beep. Release the button after the second beep.



2. Within the subsequent 20 seconds, press the small flame button (🔥) on the remote handset until you hear two short beeps confirming the synchronization is set.

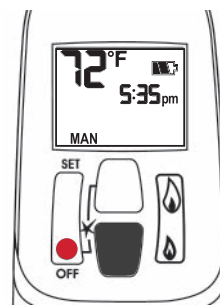

This is a one time setting only and is not required when changing the batteries in the remote handset. The remote control system is now ready to use.

Check Operation

Turn the fireplace flame up and down using the remote control to confirm that the full range of inputs is achieved—see the remote control operation instructions starting on page 8.

Set Aeration

Light the fire and allow the unit to warm up for 10–15 minutes to evaluate the flame picture. Burners are equipped with an adjustable shutter to control primary aeration. See the figures below. The shutter is factory-set to an aeration gap which will give optimum performance for the vast majority of installations.

Air Shutter

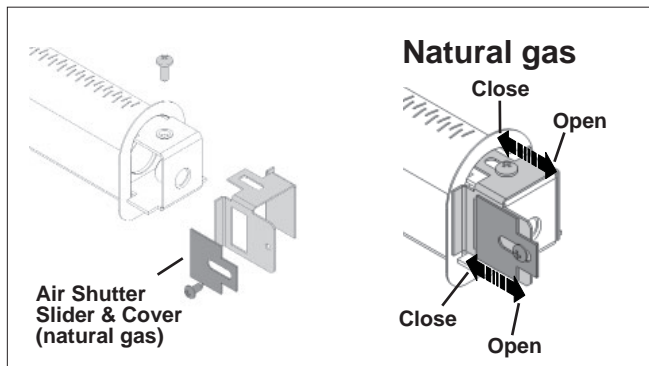

Depending of fuel bed used, altitude and other considerations, the flame picture may be improved by adjusting the aeration. The need for adjustment should be determined only by operating the appliance with the fuel bed, panels and window installed and evaluating the flame picture after a 15-minute warm-up.

Increasing aeration will cause the flames to appear more transparent and blue showing more ceramic effects glow.

Decreasing aeration will cause the flames to appear more yellow or orange showing less ceramic effects glow.

Too little aeration may result in black carbon forming and dropping into the firebox.

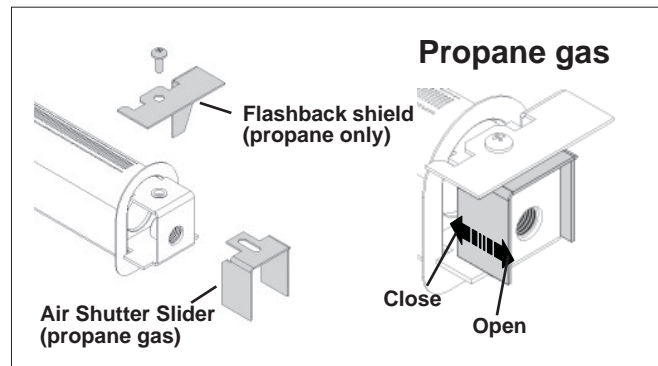

Install Front, Trim and Barrier Screen

Install the front chosen by the customer for the fireplace. Install as well the barrier screen which is provided with the front or trim.

Show the customer how to access the controls when the front or trim are installed and how to remove them the front or trim.

Follow the instructions provided with the front or trim and leave those instructions behind for the customer's further reference.

Install Remote Control Handset Wall Holder

The remote control kit for this fireplace comes complete with a wall-mounted holder. This holder is not required in all installations but is provided as an optional feature for those customers who wish to mount the remote handset to the wall.

To install the holder to the wall, find a convenient location and use the hardware provided with the kit. See the diagram on the right for required hardware and configurations. Note that the holder can be installed at the base of a light switch plate.

IMPORTANT. The location of the remote control handset is important to assure proper temperature regulation. To obtain a constant temperature, we recommend that the handset should be between 3 and 15 feet away from the appliance **but not directly above it**. We also advise that the handset should be located away from any other heat source and not in direct sunlight as this may affect the temperature sensor located in the remote handset.

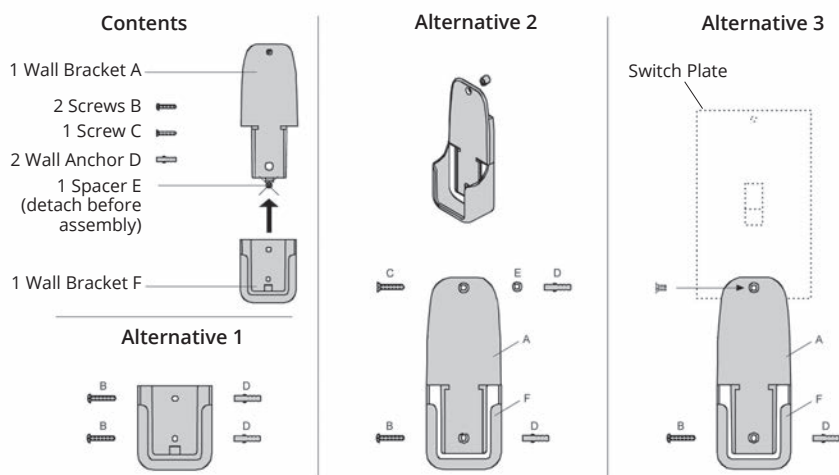

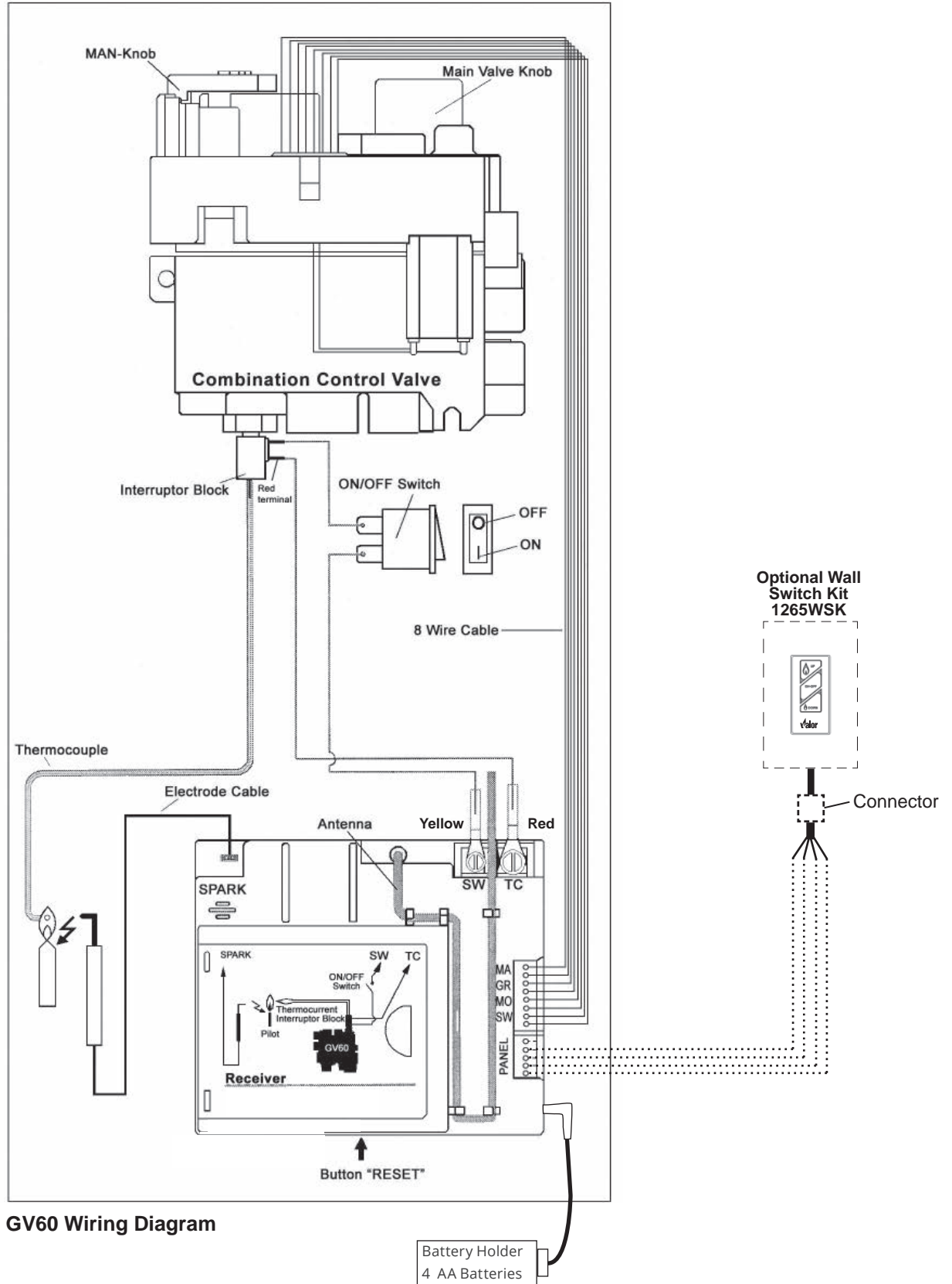

Wiring Diagram

**QUALIFIED
INSTALLER**



GV60 Wiring Diagram

Approved Venting Components

Approved Direct Vent Suppliers for Valor Models 530⁶, 534, 650 and MF28⁷										
 		Venting Parts Code / availability by Manufacturer								
		DURA-VENT	SELKIRK	ICC EXCEL DIRECT	SECURE VENT	RLH INDUSTRIES	AMERIVENT	MILES INDUSTRIES	BDM	
Venting Parts Description										
Termination Caps	Horizontal	Standard Co-axial	46DVA-HC	4DT-HC	TM-4HT	—	—	4DHC round	658DVK2	940160
		Deluxe Co-axial	—	—	TM-4RHT	—	—	4DHCS square	—	940160
		High Wind Co-axial	—	—	—	SV4CHC	—	—	—	—
	Vertical	Standard Co-axial	46DVA-VC	4DT-VT	—	—	HSDV4658-1313	4DVC	—	940264
								4DH-1313		940364
								—		940206LP
		High Wind Co-axial	46DVA-VCH	—	TM-4SVT	SV4CGV	—	—	—	—
		Extended Co-axial	46DVA-VCE	—	—	—	—	—	—	—
		Co-linear	—	—	TM-IVT	3PDVCV	HS-C33U-99	HCL-99-33	559CLT	940033B
							HS-C33F-1313	HCL-913-33		940034B
						HCL-1313-33	720SWK ⁶	940033HWS		
								940033RD		
Snorkel, 14" Rise	46DVA-SNK14	4DT-ST14	TM-4ST14	—	—	—	4D14S	—	94040614	
Snorkel, 36" Rise	46DVA-SNK36	4DT-ST36	TM-4ST36	—	—	—	4D36S	—	94040636	
Vent Adapters / Couplers	Universal Adapter 3" Flex Coupler	2150	—	TM-CFAA3	—	—	—	—	95090390	
	Valor Adapter	817VAK	—	TM-4AA2	—	—	4DSC-V	—	—	
	Co-linear Flex Connector	46DVA-ADF	—	—	—	—	—	—	—	
	Co-axial-to-Co-linear Adapter	46DVA-GCL 46DVA-CLAA	—	TM-4CAA	—	—	4DCAB33	556CLA	940106433	
	Co-linear-to-Co-axial Adapter	46DVA-GK 46DVA-CLTA	—	TM-4CTA	—	—	4DCAT33	—	—	
	DV to B-Vent Adapter	—	—	—	—	—	—	DVA5BV ⁷	—	
Aluminum Flexible Liner	3" or 4" diameter	NOTE: 2-ply liner approved to CAN/ULC S635 suitable for venting gas appliances. As manufactured by Z-Flex, Flexmasters or others.								
		2280 Series	AF3-35L	TM-ALK33	—	—	—	—	952703	
				TM-ALT33	—	—	—	—	952704	
Adjustable Pipe Length and Pipe Extensions 4" x 6-5/8"	Galvanized or Black	46DVA-08A 46DVA-08AB (3" to 7")	4DT-ADJ 4DT-ADJ(B)	—	—	—	4D7A or 4D7AB (3" to 5")	—	94610608 (4" to 8-1/2")	
		Galvanized or Black	46DVA-16A 46DVA-16AB (3" to 14-1/2")	—	TC-4DLS1 TC-4DLS1B	SV4LA SV4LBA	—	4D12A or 4D12AB (3" to 10")	—	94610616 (4" to 16")
	Galvanized or Black	46DVA-17TA 46DVA-17TAB (11" to 17")	—	TC-4DLS2 TC-4DLS2B (1-7/8" – 21")	SV4LA12 SV4LBA12	—	4D16A or 4D16AB (3" to 14")	—	—	
	Galvanized or Black	46DVA-24TA 46DVA-24TAB (17" to 24")	—	TC-4DLA30 TC-DLA30B (16.5" – 29")	SV4LA24 SV4LBA24	—	4D26A or 4D26AB (3" to 24")	—	—	
	Co-axial Flex	46DVA-48FF 46DVA-120FF	—	—	—	—	—	—	—	
	DV 45° Elbows	Galvanized	46DVA-E45	—	TE-4DE45	—	—	4D45L	—	94620645
Black		46DVA-E45B	—	TE-4DE45B	SV4EBR45	—	4D45LB	—	94620645B	
Galvanized Swivel		—	4DT-EL45	—	SV4E45	—	—	—	—	
Black Swivel		—	4DT-EL45(B)	—	SV4EB45	—	—	—	—	
DV 90° Elbows	Galvanized	46DVA-E90	—	TE-4DE90	—	—	4D90L	—	—	
	Black	46DAV-E90B	—	TE-4DE90B	SV4EBR90	—	4D90LB	—	—	
	Galvanized Swivel	—	4DT-EL90	—	SV4E90	—	—	—	94620690	
	Black Swivel	—	4DT-EL90(B)	—	SV4EB90	—	—	—	94620690B	

Approved Venting Components

**QUALIFIED
INSTALLER**

Venting Parts Description			Venting Parts Code / availability by Manufacturer							
			DURA-VENT	SELKIRK	ICC EXCEL DIRECT	SECURE VENT	RLH INDUSTRIES	AMERIVENT	MILES INDUSTRIES	BDM
Pipes 4" x 6 5/8" (ID x OD)	6" long	Galvanized	46DVA-06	4DT-06	TC-4DL6	SV4L6	—	—	—	94610606
		Black	46DVA-06B	4DT-06(B)	TC-4DL6B	SV4LB6	—	—	—	90410606B
	7" long	Galvanized	—	—	—	—	—	4D7	—	—
		Black	—	—	—	—	—	4D7B	—	—
	9" long	Galvanized	46DVA-09	4DT-09	TC-4DL9	—	—	—	—	94610609
		Black	46DVA-09B	4DT-09(B)	TC-4DL9B	—	—	—	—	94610609B
	12" long	Galvanized	46DVA-12	4DT-12	TC-4DL1	SV4L12	—	4D12	—	94610612
		Black	46DVA-12B	4DT-12(B)	TC-4DL1B	SV4LB12	—	4D12B	—	94610612B
	18" long	Galvanized	46DVA-18	4DT-18	—	—	—	—	—	94610618
		Black	46DVA-18B	4DT-18(B)	—	—	—	—	—	94610618B
	24" long	Galvanized	46DVA-24	4DT-24	TC-4DL2	SV4L24	—	4D2	—	94610624
		Black	46DVA-24B	4DT-24(B)	TC-4DL2B	SV4LB24	—	4D2B	—	94610624B
	36" long	Galvanized	46DVA-36	4DT-36	TC-4DL3	SV4L36	—	4D3	—	94610636
		Black	46DVA-36B	4DT-36(B)	TC-4DL3B	SV4LB36	—	4D3B	—	94610636B
	48" long	Galvanized	46DVA-48	4DT-48	TC-4DL4	SV4L48	—	4D4	—	94610648
		Black	46DVA-48B	4DT-48(B)	TC-4DL4B	SV4LB48	—	4D4B	—	94610648B
Flashings	Roof Flashing 0/12-6/12		46DVA-F6	4DT-AF6	TF-4FA	SV4FA	—	4DF (0/12-5/12)	—	949606012
	Roof Flashing 7/12-12/12		46DVA-F12	4DT-AF12	TF-4FB	SV4B	—	4DF12 (6/12-12/12)	—	949606712
	Flat Roof Flashing		46DVA-FF	—	TF-4F	SV4F	—	—	—	949606001
	Masonry Flashing		—	—	TF-4MF	—	—	—	559FSK	—
	New Siding Flashing		—	—	—	—	—	—	658NSFK	—
Various Venting System Parts	Wall Thimble		46DVA-WT	4DT-WT	TM-4WT	SV4RSM	—	4DWT	—	949064U
	Storm Collar		46DVA-SC	4DT-SC	TM-SC	SV4AC	—	4DSC	—	94960608
	Decorative Plate		46DVA-DC	4DT-CS	TM-4TR TM-4TP	SV4PF	—	4DFPB	—	94940612
	Cathedral Ceiling Support		46DVA-CS	4DT-CCS	TM-4SS	—	—	4DRSB	—	949506KT
	Ceiling Firestop / Floor Support		46DVA-FS	4DT-FS	TM-4RDS	SV4BF	—	4DFSP	—	94980612
					TM-CS	SV4SD				
	Attic Radiation Shield / Firestop		—	—	TM-4AS	—	—	4DAIS12 (12")	—	94930620A
								4DAIS36 (36")		
	Wall Strap		46DVA-WS	4DTWS	TM-WS	—	—	4DWS	—	949164
	Vinyl Siding Standoff		46DVA-VSS	4DT-VS	TM-VSS	SV4VS	—	4DHVS	—	94800615S
Elbow Strap / Offset Support		46DVA-ES	4DT-OS	TM-OS	—	—	—	—	949264	
Terminal Guard		46DVA-WG	—	TM-HTS	—	—	—	845TG	940164SHRD	
				TM-RHTS				658TG		

- Notes:**
1. All listed above co-axial pipes and fittings require Valor 817VAK Adapter Kit to fit Valor's smooth collars (Valor adapter 4DSC-V by American Metal Products may also be used).
 2. Follow instructions supplied with each manufacturer's components.
 3. Unless otherwise specified, all the parts and assemblies from the above table are to be used with 4" x 6-5/8" pipes.
 4. Do not mix components from different vent manufacturers.
 5. Termination caps manufactured by RLH Industries or American Metal Products are from Homestyle Chimney Collection and can be ordered in one of the following finishes: a) aluminium; b) black powder coated; c) solid copper.
 6. The 720SWK Sidewall Co-Linear Kit can only be installed on the 530 models (CANNOT be used with coal effect models).
 7. The DVA5BV DV to BV adapter CANNOT be installed on the MF28 models.

**State of Massachusetts Carbon Monoxide
Detector/Vent Terminal Signage
Requirements**

For all side wall horizontally vented gas fueled equipment installed in every dwelling, building or structure used in whole or in part for residential purposes, including those owned or operated by the Commonwealth and where the side wall exhaust vent termination is less than seven (7) feet above finished grade in the area of the venting, including but not limited to decks and porches, the following requirements shall be satisfied:

1. INSTALLATION OF CARBON MONOXIDE DETECTORS. At the time of installation of the side wall horizontal vented gas fueled equipment, the installing plumber or gas fitter shall observe that a hard wired carbon monoxide detector with an alarm and battery back-up is installed on the floor level where the gas equipment is to be installed. In addition, the installing plumber or gas fitter shall observe that a battery operated or hard wired carbon monoxide detector with an alarm is installed on each additional level of the dwelling, building or structure served by the side wall horizontal vented gas fueled equipment. It shall be the responsibility of the property owner to secure the services of qualified licensed professionals for the installation of hard wired carbon monoxide detectors.

a. In the event that the side wall horizontally vented gas fueled equipment is installed in a crawl space or an attic, the hard wired carbon monoxide detector with alarm and battery back-up may be installed on the next adjacent floor level.

b. In the event that the requirements of this subdivision can not be met at the time of completion of installation, the owner shall have a period of thirty (30) days to comply with the above requirements; provided, however, that during said thirty (30) day period, a battery operated carbon monoxide detector with an alarm shall be installed.

2. APPROVED CARBON MONOXIDE DETECTORS. Each carbon monoxide detector as required in accordance with the above provisions shall comply with NFPA 720 and be ANSI/UL 2034 listed and IAS certified.

3. SIGNAGE. A metal or plastic identification plate shall be permanently mounted to the exterior of the building at a minimum height of eight (8) feet above grade directly in line with the exhaust vent terminal for the horizontally vented gas fueled heating appliance or equipment. The sign shall read, in print size no less than one-half (1/2) inch in size, "GAS VENT DIRECTLY BELOW. KEEP CLEAR OF ALL OBSTRUCTIONS".

4. INSPECTION. The state or local gas inspector of the side wall horizontally vented gas fueled equipment shall not approve the installation unless, upon inspection, the inspector observes carbon monoxide detectors and signage installed in accordance with the provisions of 248 CMR 5.08(2)(a)1 through 4.

(b) **EXEMPTIONS:** The following equipment is exempt from 248 CMR 5.08(2)(a)1 through 4:

1. The equipment listed in Chapter 10 entitled "Equipment Not Required To Be Vented" in the most current edition of NFPA 54 as adopted by the Board; and
2. Product Approved side wall horizontally vented gas fueled equipment installed in a room or structure separate from the dwelling, building or structure used in whole or in part for residential purposes.

(c) **MANUFACTURER REQUIREMENTS - GAS EQUIPMENT VENTING SYSTEM PROVIDED.** When the manufacturer of Product Approved side wall horizontally vented gas equipment provides a venting system design or venting system components with the equipment, the instructions provided by the manufacturer for installation of the equipment and the venting system shall include:

1. Detailed instructions for the installation of the venting system design or the venting system components; and
2. A complete parts list for the venting system design or venting system.

(d) MANUFACTURER REQUIREMENTS - GAS EQUIPMENT VENTING SYSTEM NOT PROVIDED.

When the manufacturer of a Product Approved side wall horizontally vented gas fueled equipment does not provide the parts for venting the flue gases, but identifies “special venting systems”, the following requirements shall be satisfied by the manufacturer:

1. The referenced “special venting system” instructions shall be included with the appliance or equipment installation instructions; and
2. The “special venting systems” shall be Product Approved by the Board, and the instructions for that system shall include a parts list and detailed installation instructions.

(e) A copy of all installation instructions for all Product Approved side wall horizontally vented gas fueled equipment, all venting instructions, all parts lists for venting instructions, and/or all venting design instructions shall remain with the appliance or equipment at the completion of the installation.

Warranty

THIS WARRANTY DOES NOT APPLY TO OUTDOOR INSTALLATIONS—SEE WARRANTY SUPPLIED WITH GV60CKO OUTDOOR KIT.

If you have a problem with this unit, please contact your dealer or supplier immediately. Under no circumstances should you attempt to service the unit in any way by yourself. The warranties in paragraphs 1 and 2 are provided only to the initial user of this unit, are not transferable and are subject to the conditions and limitations in paragraphs 3, 4 and 5. Please review the conditions and limitations carefully and strictly follow their requirements.

1. Extended Warranty Coverage

For a period of up to ten (10) years, Miles Industries Ltd., (the "Company") or its appointed distributor will at its option pay the initial owner for the repair of, or will exchange the following parts or components which are found to be defective in material or workmanship under normal conditions of use and service:

Maximum Warranty Period		10 years
Part or Component	Defect Covered	
Exterior steel casing	Corrosion	✓
Glass	Loss of structural integrity	✓
Cast iron parts	Corrosion	✓
Firebox and heat exchanger	Corrosion (but not discoloration) causing loss of structural integrity	✓

2. Two-Year Parts Warranty

In addition, for two (2) years from the date of purchase, the Company, at its option, will repair or exchange all parts and components not listed above but that are found to have a bona fide defect in material or workmanship under normal conditions of use.

3. Conditions and Limitations

- a) The warranty registration card must be completed by the initial owner and returned to the company within 90 days. Alternatively, the warranty registration form may be filled out online at www.valorfireplaces.com
- b) Installation and maintenance must be performed by an authorized and trained dealer in accordance with the Company's installation instructions.
- c) This warranty is void where installation of the unit does not conform to all applicable codes including national and local gas appliance installation codes and building and fire codes.
- d) The owner must comply with all operating instructions.
- e) The Company is not responsible for the labor costs to remove defective parts or re-install repaired or replacement parts.
- f) The initial owner of the unit will be responsible for any shipping charges for replacement parts as well as travel time incurred by the dealer to perform the warranty work.

- g) This warranty applies to non-commercial use and service and is void if it is apparent that there is abuse, misuse, alteration, improper installation, accident or lack of maintenance to the unit.
- h) The warranty does not cover damage to the unit through:
 - i) Improper installation, operational or environmental conditions.
 - ii) Inadequate ventilation in the area or competition for air from other household equipment or appliances.
 - iii) Chemicals, dampness, condensation, or sulphur in the fuel supply lines which exceeds industry standards.
- i) This warranty does not cover glass, log breakage or damage to the unit while in transit.
- j) The Company does not allow anyone to extend, alter or modify this warranty and assumes no responsibility for direct, indirect or consequential damages caused by the unit. State or provincial laws where the initial user or user resides may provide specific rights extending this warranty and, if so, the Company's sole obligation under this warranty is to provide labor and/or materials in accordance with those laws.

4. Discharge of Liability

After two (2) years from the date of purchase, the Company may, at its option, fully discharge all obligations under this warranty by paying to the first owner the wholesale price of, or replacing, any defective parts.

5. No Other Warranty

All obligations to repair this unit are defined in this warranty. Some states or provinces may specifically mandate additional obligations on the part of manufacturers, but in the absence of such specific legislation, there is no other warranty or obligation expressed or implied.

Replacement Parts

	Description	Part no.
1	Side wall support (2)	330A898
2	Rear wall support	320B320
4	Velcro strip	4000022
5	Port cover	4000828AH
6	Inner vent collar	340B174
7	Inner vent collar seal	620B973
8	Top vent collar seal	568399
9	Top vent cover plate	330A902
10	Wall bracket spacer (2)	320B360AZ
11	Outer vent collar seal	568399
12	Outer vent collar	330A888
13	Restrictor plates (2)	4002895
14	Adjustable plates (2)	4002896
19	Window unit	050A216
20	Window screw assy (2)	000B214S
21	Burner unit incl. #22 (natural gas)	3000025
	Burner unit incl. #22 (propane gas)	740K185
22a	Aeration shutter slider (natural gas)	4002345
	Aeration shutter cover (natural gas)	4002346
22b	Aeration shutter slider (propane gas)	320B293
	Flashback shield (propane gas)	3000371
23	Pilot unit complete (natural gas)	4000062
	Pilot unit complete (propane gas)	4000063
24	Pilot injector (natural gas)	4002511
	Pilot injector (propane gas)	720A195
25	Thermocouple	4000061
26	Hooked olive for pilot	720A196
27	Electrode	720A543
28	Electrode nut	720A200
29	Olive nut for pilot	420K385
30	Pilot shield	4000144
31	Pilot support bracket	330A904
32	Main burner pipe	030A225
33	Olive nut	220K567
34	Olive	420K342
35	Base support bracket (2)	330A894
35a	Spacer angle (2)	4000355
36	Elbow injector (natural gas)	720A580
	Elbow injector (propane gas)	9730013
38	Pilot pipe	030A226
39	Snap off olive nut	220K913
40	Window support	320B399
41	Switch bracket	4001070
41a	Switch with cable	4001036
41b	Cable interrupter/receiver	4001035
42	Interrupter block	4001037
43a	GV60 Valve (natural gas)	4003094
43b	GV60 Valve (propane gas)	4003107
44	Ignition cable	4001039

	Description	Part no.
44a	Ignition cable sleeve	4002244
45	Receiver G6R-R3AM-ZV (CP)	4001911
46	Handset G6R H3T5-ZV (BJ)	4001910
47	Wall mount holder	9000008
48	Wiring harness	4001187
49	Hot glass warning plate	4003093
50	Ceramic coals & liners set	530CSK
51	Ceramic coal set	000B245
52	Centre left coal	640K615
53	Base coal	650K237
54	Centre right coal	640K616
55	Front right coal	640K618
56	Front left coal	640K617
57	Ceramic reversible walls set	4001160
58	Rear reversible panel	4001161
59	LH reversible panel	4001162
60	RH reversible panel	4001163
61	Traditional logs & liners set	530LSK
62	Traditional log set	4000162
63	Right middle log	4000372
64	Right side front log	4000470
65	Front log	4000370
66	Base log	4000368
67	Left middle side log	4000371
68	Rear log	4000369
69	Ceramic reversible walls set	4001160
70	Rear reversible panel	4001161
71	LH reversible panel	4001162
72	RH reversible panel	4001163
73	Ceramic rocks & liners set	530RSK
74	Top far left rock	4001867
75	Top left rock	4001868
76	Top right rock	4001869
77	Top far right rock	4001870
78	Left rock	4001877
79	Right rock	4001878
80	Bottom left rock	4001874
81	Bottom center rock	4001875
82	Bottom right rock	4001876
83	Middle left rock	4001871
84	Middle center rock	4001872
85	Middle right rock	4001873
86	Rock base	4001880
87	LH reversible wall	4001162
88	Rear fluted wall	4001881
89	RH reversible wall	4001163
90	Rock base support	4001882AH
91	Ceramic platform	4001879

Replacement Parts

	Description	Part no.
92	Driftwood Kit	530DWK
93	Log Set (including pebbles)	4005603
94	Base log	4005887
95	Rear log	4005888
96	Left log	4005889
97	Right log	4005890
98	Centre log	4005891
99	Brown beach pebble	4003082
100	Small grey beach pebble	4003086
101	Grey beach pebble	4003083
102	Small beige beach pebble	4003087
103	Metal platform	4006017AH
104	Rear liner panel fluted	4001881
105	Reversible LH brick/fluted panel	4001162
106	Reversible RH brick/fluted panel	4001163
107	Rear liner holder support	4001882AH
108	GV60 Valve repair kit	4004544
109	Auxiliary battery holder	4006553
110	Battery holder cable 1500 mm	4006552

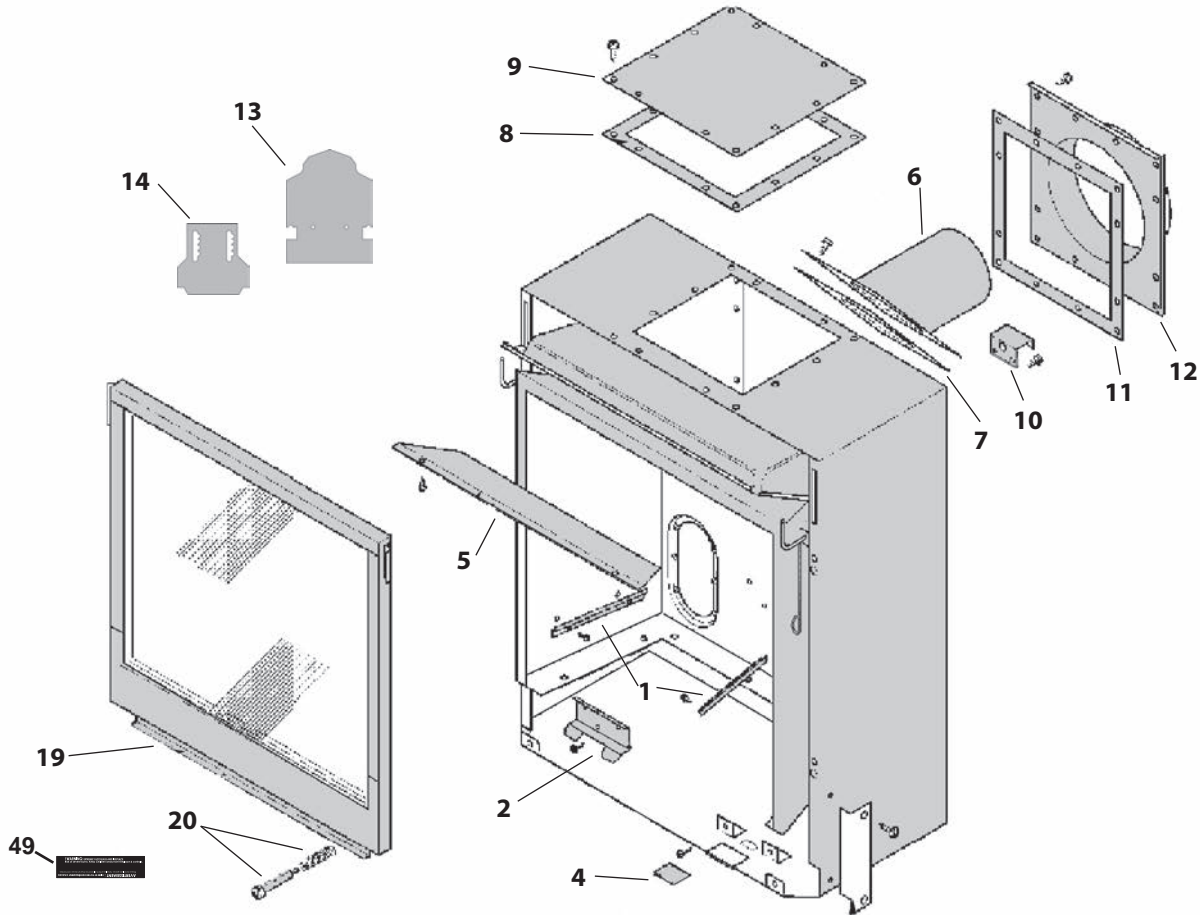

Replacement Parts

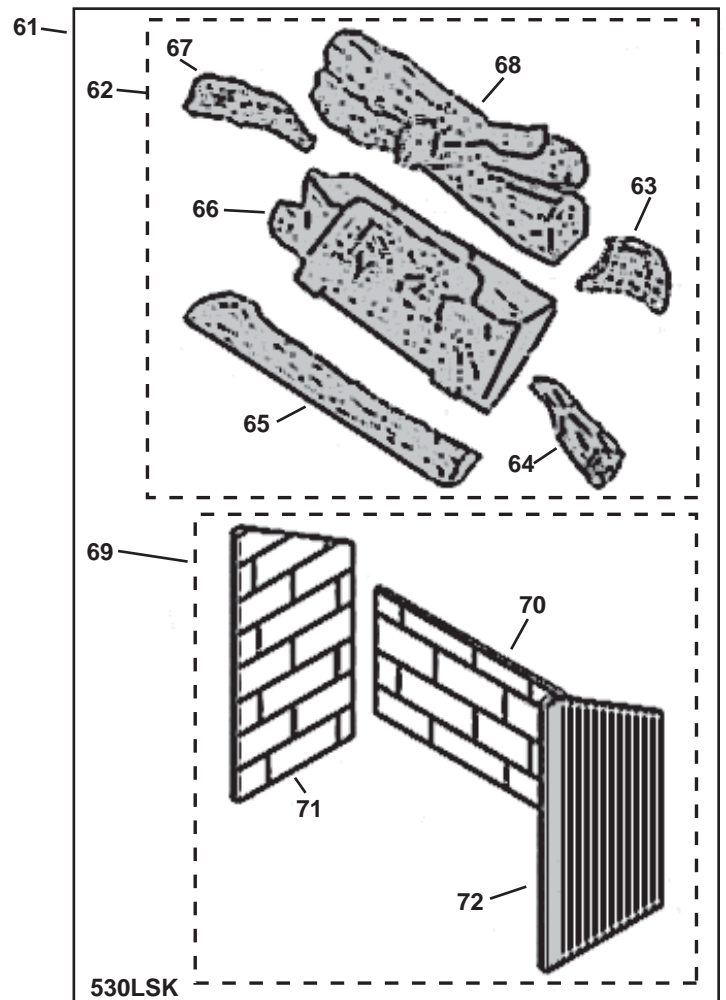
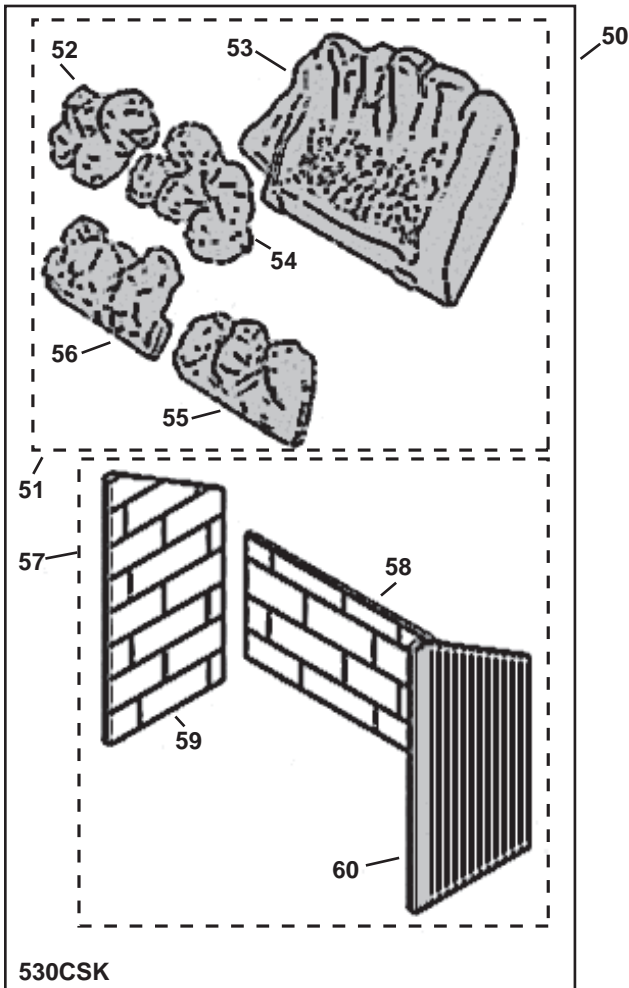
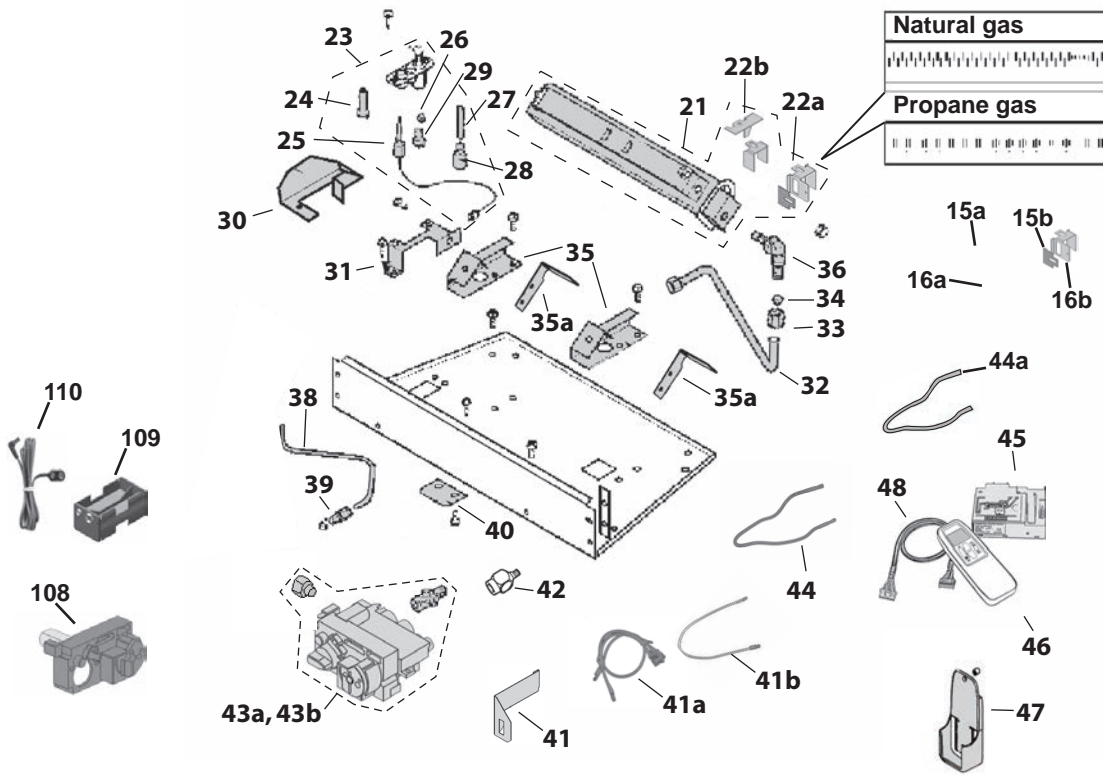

Replacement Parts

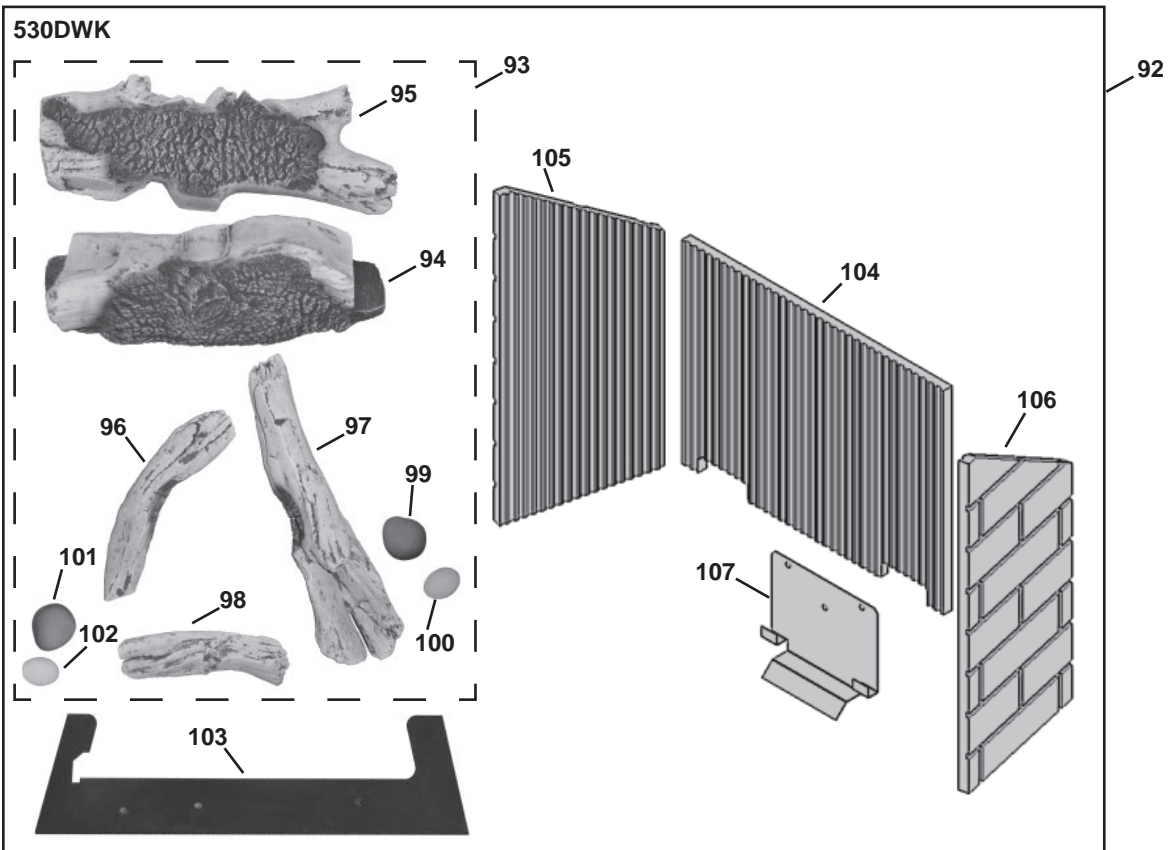
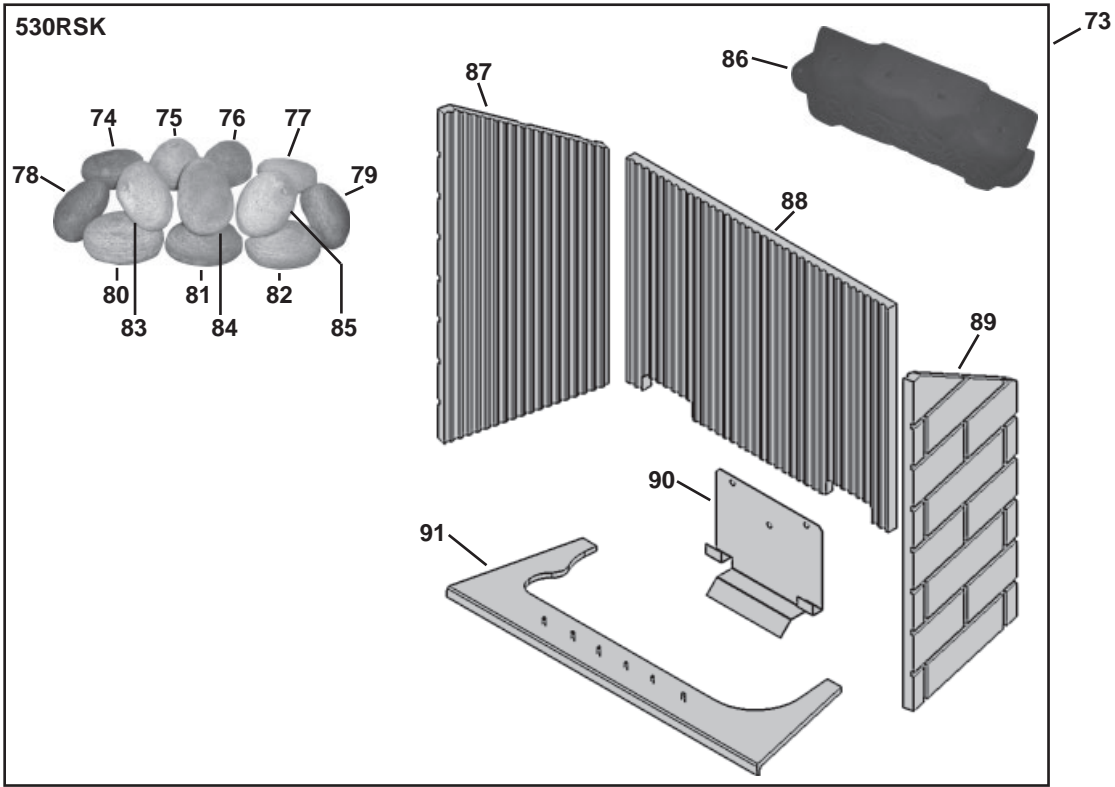

Thank You ...

For purchasing a Valor by Miles Industries. Your new radiant gas heater is a technical appliance that must be installed by a qualified installer.

Please fill in the information below. The information provided will be used for customer records only.

Fireplace Information

Model Number: 530 IN or IP / INSTALLED OUTDOOR

Serial Number:

Date Purchase (yyyy-mm-dd):

Dealer:

Customer Information

First Name:

Last Name:

Contact Information

Email:

Mailing Address

Address:

City:

Province/State:

Postal/Zip Code:

Country:

Cut out page, fill information, and mail to Miles Industries Ltd.

Online Warranty registration at www.valorfireplaces.com



Tape Shut



Fold here



Postage
needed

Valor Fireplaces
190 - 2255 Dollarton Highway
North Vancouver, BC V7H 3B1
Canada

Online Warranty registration at www.valorfireplaces.com

Thank you for choosing a Valor Product