



Madrona

M1



Madrona Free Standing Direct-Vent Top or Rear Vent Stove MF28EN (NG) / MF28EP (LPG)

Engine to be installed ONLY with the cast stove body
MFCS01 or MFCS02



Installation & Operating Instructions

*INSTALLER: Leave this manual with the appliance.
CONSUMER: Retain this manual for future reference.*

WARNING: If the information in these instructions is not followed exactly, a fire or explosion may result causing property damage, personal injury or loss of life.

Do not store or use gasoline or other flammable vapors and liquids in the vicinity of this or any other appliance.

WHAT TO DO IF YOU SMELL GAS

- Do not try to light the appliance.
- Do not touch any electrical switch; do not use any phone in your building.
- Immediately call your gas supplier from a neighbor's phone. Follow the gas supplier's instructions.
- If you cannot reach your gas supplier, call the fire department.

Installation and service must be performed by a qualified installer, service agency or the gas supplier.

PLEASE READ THIS MANUAL BEFORE INSTALLING AND OPERATING THIS APPLIANCE.

This appliance may be installed in an after-market permanently located, manufactured (mobile) home where not prohibited by local codes.

This appliance is only for use with the type of gas indicated on the rating plate. This appliance is not convertible for use with other gases, unless a certified kit is used.

This appliance is a domestic room-heating appliance. It must not be used for any other purposes such as drying clothes, etc.

This appliance is suitable for installation in a bedroom or bed sitting room.

Massachusetts: The piping and final gas connection must be performed by a licensed plumber or gas fitter in the State of Massachusetts. Also, see Carbon Monoxide Detector requirements under "Safety and Warning Information" on page 5.

Manufactured by
MILES INDUSTRIES LTD.

British Columbia, Canada
www.valorfireplaces.com

Thank You ...

For purchasing a Valor Madrona. Your new radiant gas heater is a technical appliance that must be installed by a qualified dealer. Each Madrona is fully tested during the production process for your safety and comfort.

Your unit has been professionally installed by:

Dealer Name _____

Phone Number _____

Should you encounter an operational problem, call your dealer immediately. Do not try to repair the unit as you may cause an injury or damage the fireplace.

The information contained in this installation manual is believed to be correct at the time of printing. Miles Industries Ltd. reserves the right to change or modify any information or specifications without notice. Miles Industries Ltd. grants no warranty, implied or stated, for the installation or maintenance of your heater, and assumes no responsibility for any consequential damage(s).

 The logo for the National Fireplace Institute (NFI) Advocate. It features a square border containing the text "NATIONAL FIREPLACE INSTITUTE" at the top, "NFI" in a large font in the center, a stylized flame icon below "NFI", and "ADVOCATE" at the bottom.	<p>We recommend that our gas hearth products be installed and serviced by professionals who are certified in the United States by NFI (National Fireplace Institute®).</p>
---	---

Table of Contents

Specifications.....	7
Dimensions & Clearances.....	8
Venting.....	10
Installation.....	15
Packs Contents—Appliance & Castings.....	15
Appliance Preparation.....	16
Supply Gas.....	21
Ceramic Logs.....	22
Window Refitting.....	23
Initial Remote Control Set-up.....	23
Operation Check & Aeration Settings Adjustment.....	24
Front & Top Installation.....	24
Remote Control Handset Wall Holder Installation.....	25
Owner’s Information.....	26
Wiring Diagram.....	32
Options.....	33
Venting accessories.....	34
Warranty.....	36
Replacement Parts.....	38

! WARNING



HOT GLASS WILL CAUSE BURNS.
DO NOT TOUCH GLASS UNTIL COOLED.
NEVER ALLOW CHILDREN TO TOUCH GLASS.

Safety & Warning Information

READ and **UNDERSTAND** all instructions carefully before starting the installation. **FAILURE TO FOLLOW** these installation instructions may result in possible fire hazard and will void the warranty.

Prior to the first firing of the fireplace, **READ** the Owner's Information section of this manual.

DO NOT USE this appliance if any part has been under water. Immediately, **CALL** a qualified service technician to inspect the unit and to replace any part of the control system and any gas control that has been under water.

THIS UNIT IS NOT FOR USE WITH SOLID FUEL.

Installation and repair should be **PERFORMED** by a qualified service person. The appliance and venting system should be **INSPECTED** before initial use and at least annually by a professional service person. More frequent cleaning may be required due to excessive lint from carpeting, bedding, etc. It is **IMPERATIVE** that the unit's control compartment, burner, and circulating air passageways **BE KEPT CLEAN** to provide for adequate combustion and ventilation air.

Always **KEEP** the appliance clear and free from combustible materials, gasoline, and other flammable vapors and liquids.

NEVER OBSTRUCT the flow of combustion and ventilation air. Keep the front of the appliance **CLEAR** of all obstacles and materials for servicing and proper operation.

Due to the high temperature, the appliance should be **LOCATED** out of traffic areas and away from furniture and draperies. Clothing or flammable material **SHOULD NOT BE PLACED** on or near the appliance.

Children and adults should be **ALERTED** to the hazards of high surface temperature and should **STAY AWAY** to avoid burns or clothing ignition. Young children should be **CAREFULLY SUPERVISED** when they are in the same room as the appliance.

This unit **MUST** be used with a vent system as described in this installation manual. **NO OTHER** vent system or components **MAY BE USED**.

This gas fireplace and vent assembly **MUST** be vented directly to the outside and **MUST NEVER** be attached to a chimney serving a separate solid fuel burning appliance. Each gas appliance **MUST USE** a separate vent system. Common vent systems are **PROHIBITED**.

INSPECT the external vent cap on a regular basis to make sure that no debris, plants, trees, shrubs are interfering with the air flow.

The glass door assembly **MUST** be in place and sealed before the unit can be placed into safe operation.

DO NOT OPERATE this appliance with the glass door removed, cracked, or broken. Replacement of the glass door should be performed by a licensed or qualified service person. **DO NOT** strike or slam the glass door.

The glass door assembly **SHALL ONLY** be replaced as a complete unit, as supplied by the fireplace manufacturer. **NO SUBSTITUTE** material may be used.

DO NOT USE abrasive cleaners on the glass door assembly. **DO NOT ATTEMPT** to clean the glass door when it is hot.

TURN OFF the gas before servicing this appliance. It is recommended that a qualified service technician perform an appliance check-up at the beginning of each heating season.

Any safety screen or guard removed for servicing **MUST BE REPLACED** before operating this appliance.

DO NOT place furniture or any other combustible household objects within 36" of the fireplace front.

BE CAREFUL not to put any decorating objects sensitive to heat on the stove or too close to the stove as it gets very hot when operating.

DO NOT use this heater as a temporary source of heat during construction.

NOTE: When operating your new fireplace for the first time, some vapors may be released due to the burning of curing compounds used in the manufacture of the appliance. They may cause a slight odor and could cause the flames to be the full height of the firebox, or even slightly higher, for the first few hours of operation. It is also possible that these vapors could set off any smoke detection alarms in the immediate vicinity. These vapors are quite normal on new appliances. We recommend opening a window to vent the room. After a few hours' use, the vapors will have disappeared and the flames will be at their normal height.

Safety & Warning Information

California **State of California. Proposition 65 Warning.** Fuels used in gas, wood-burning or oil fired appliances, and the products of combustion of such fuels, contain chemicals known to the State of California to cause cancer, birth defects and other reproductive harm. *California Health & Safety Code Sec. 25249.6.*

Massachusetts **State of Massachusetts Carbon Monoxide Detector/Vent Terminal Signage Requirements**

For all side wall horizontally vented gas fueled equipment installed in every dwelling, building or structure used in whole or in part for residential purposes, including those owned or operated by the Commonwealth and where the side wall exhaust vent termination is less than seven (7) feet above finished grade in the area of the venting, including but not limited to decks and porches, the following requirements shall be satisfied:

1. **INSTALLATION OF CARBON MONOXIDE DETECTORS.** At the time of installation of the side wall horizontal vented gas fueled equipment, the installing plumber or gasfitter shall observe that a hard wired carbon monoxide detector with an alarm and battery back-up is installed on the floor level where the gas equipment is to be installed. In addition, the installing plumber or gasfitter shall observe that a battery operated or hard wired carbon monoxide detector with an alarm is installed on each additional level of the dwelling, building or structure served by the side wall horizontal vented gas fueled equipment. It shall be the responsibility of the property owner to secure the services of qualified licensed professionals for the installation of hard wired carbon monoxide detectors.

a. In the event that the side wall horizontally vented gas fueled equipment is installed in a crawl space or an attic, the hard wired carbon monoxide detector with alarm and battery back-up may be installed on the next adjacent floor level.

b. In the event that the requirements of this subdivision can not be met at the time of completion of installation, the owner shall have a period of thirty (30) days to comply with the above requirements; provided, however, that during said thirty (30) day period, a battery operated carbon monoxide detector with an alarm shall be installed.

2. **APPROVED CARBON MONOXIDE DETECTORS.** Each carbon monoxide detector as required in accordance with the above provisions shall comply with NFPA 720 and be ANSI/UL 2034 listed and IAS certified.

3. **SIGNAGE.** A metal or plastic identification plate shall be permanently mounted to the exterior of the building at a minimum height of eight (8) feet above grade directly in line with the exhaust vent terminal for the horizontally vented gas fueled heating appliance or equipment. The sign shall read, in print size no less than one-half (1/2) inch in size, "GAS VENT DIRECTLY BELOW. KEEP CLEAR OF ALL OBSTRUCTIONS".

4. **INSPECTION.** The state or local gas inspector of the side wall horizontally vented gas fueled equipment shall not approve the installation unless, upon inspection, the inspector observes carbon monoxide detectors and signage installed in accordance with the provisions of 248 CMR 5.08(2)(a)1 through 4.

Safety & Warning Information

Massachusetts State of Massachusetts Carbon Monoxide Detector/Vent Terminal Signage Requirements - Cont.

(b) EXEMPTIONS: The following equipment is exempt from 248 CMR 5.08(2)(a)1 through 4:

1. The equipment listed in Chapter 10 entitled "Equipment Not Required To Be Vented" in the most current edition of NFPA 54 as adopted by the Board; and
2. Product Approved side wall horizontally vented gas fueled equipment installed in a room or structure separate from the dwelling, building or structure used in whole or in part for residential purposes.

(c) MANUFACTURER REQUIREMENTS - GAS EQUIPMENT VENTING SYSTEM PROVIDED. When the manufacturer of Product Approved side wall horizontally vented gas equipment provides a venting system design or venting system components with the equipment, the instructions provided by the manufacturer for installation of the equipment and the venting system shall include:

1. Detailed instructions for the installation of the venting system design or the venting system components; and
2. A complete parts list for the venting system design or venting system.

(d) MANUFACTURER REQUIREMENTS - GAS EQUIPMENT VENTING SYSTEM NOT PROVIDED. When the manufacturer of a Product Approved side wall horizontally vented gas fueled equipment does not provide the parts for venting the flue gases, but identifies "special venting systems", the following requirements shall be satisfied by the manufacturer:

1. The referenced "special venting system" instructions shall be included with the appliance or equipment installation instructions; and
2. The "special venting systems" shall be Product Approved by the Board, and the instructions for that system shall include a parts list and detailed installation instructions.

(e) A copy of all installation instructions for all Product Approved side wall horizontally vented gas fueled equipment, all venting instructions, all parts lists for venting instructions, and/or all venting design instructions shall remain with the appliance or equipment at the completion of the installation.

Specifications

Approval & Codes

This appliance is certified to ANSI Z21.88b-2008 / CSA 2.33b-2008 *Vented Gas Fireplace Heater* standard for use in Canada and USA, and to CGA 2.17-91 *High Altitude Standard in Canada*. This appliance is for direct vent installations.

Conversion between fuels may only be done using the approved conversion kits listed on page 33. This appliance complies with CGA P.4.1 *Testing method for measuring annual fireplace efficiencies*.

The installation must conform to local codes or, in the absence of local codes, with the *National Fuel Gas Code, ANSI Z223.1* or the *Natural Gas and Propane Installation Code CAN/CGA-B149*. Only qualified licensed or trained personnel should install this appliance.

This appliance, when installed with the optional circulating fan kit (blower), must be electrically grounded in accordance with local codes, or, in the absence of local codes, with the *National Electrical Code, ANSI/NFPA 70* or the *Canadian Electrical Code, CSA C22.1*.

Ratings

Model (Field convertible Top or Rear Vent Outlet)	MF28EN	MF28EP
Gas	Natural	Propane
Altitude (Ft)*	0-4,500 feet*	
Input Maximum (Btu/h)	28,000	28,000
Input Minimum (Btu/h)	12,000	14,500
Manifold Pressure (in w.c.)	3.75	10.2
Minimum Supply Pressure (in w.c.)	5.0	11.0
Maximum Supply Pressure (in w.c.)	11.0	14.0
Main Burner Injector Marking	82-750	92-300
Pilot Injector Marking	62	30

*High Altitude Installations

Input ratings are shown in BTU per hour and are certified without deration for elevations up to 4,500 feet (1,370 m) above sea level. For elevations above 4,500 feet (1,370 m) in USA, installations must be in accordance with the current ANSI Z223.1 and/or local codes having jurisdiction. Heating value of gas in some areas is reduced to compensate for elevation—consult your local gas utility to confirm. For installations at elevations above 4,500 feet (1,370 m) in Canada, please consult provincial and/or local authorities having jurisdiction.

Supply Gas

Heater engine MF28EN is used with natural gas.
 Heater engine MF28EP is used with propane gas.
 The supply pressure must be between the limits shown in the Ratings section above.
 The supply connection is 3/8" NPT female.

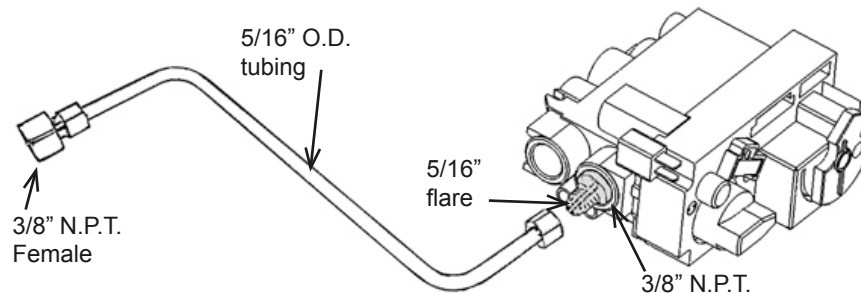

Electrical

The Madrona stove does not require an electrical power source unless it is fitted with an optional circulating fan—see page 19.

Dimensions & Clearances

Dimensions

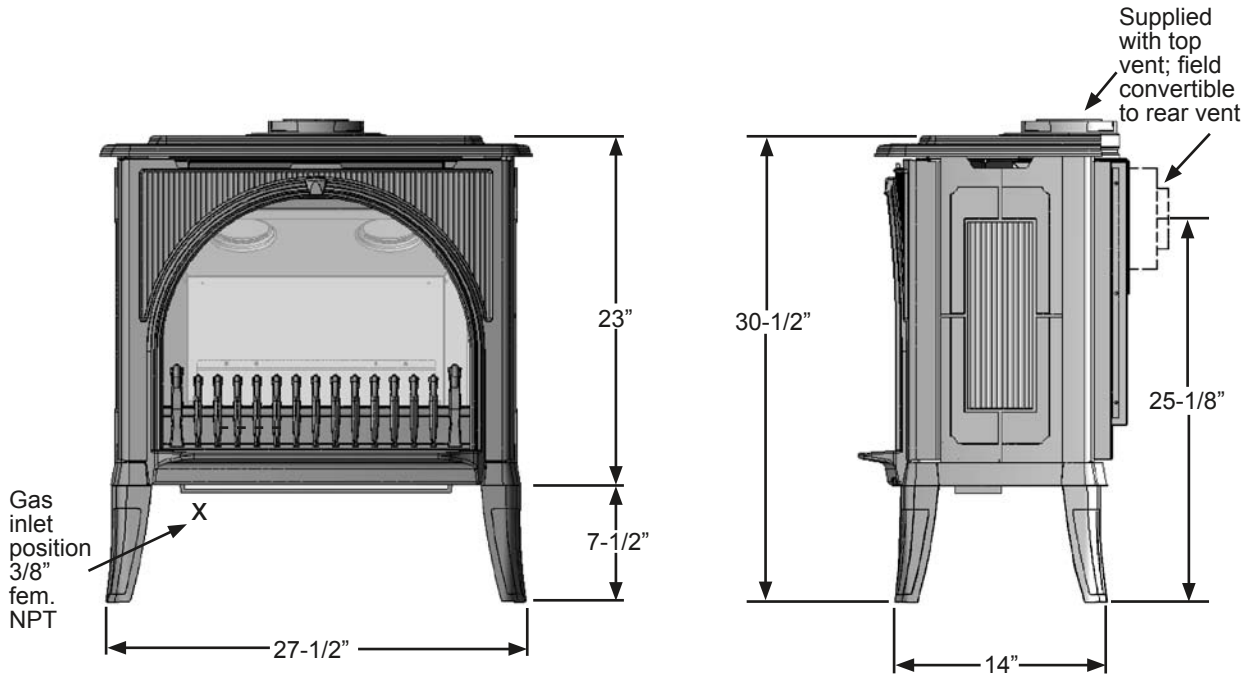
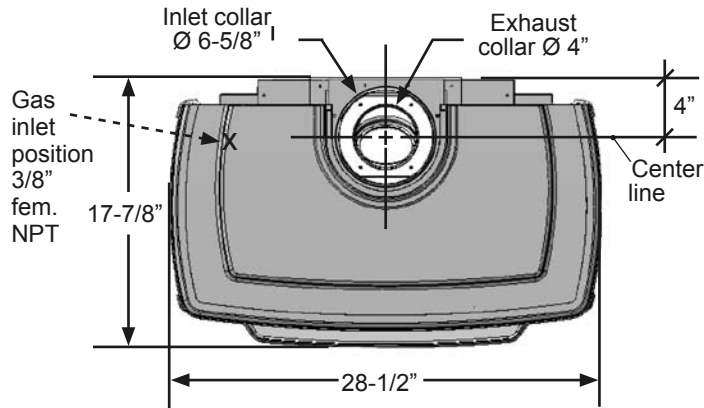

Hearth Requirements

This unit is approved for mounting directly on combustible wood flooring. If installed directly on carpeting, vinyl or soft combustible floor other than wood, it must be installed on a metal or wood panel covering a minimum surface of 15" deep by 28" width.

Dimensions & Clearances

Clearances

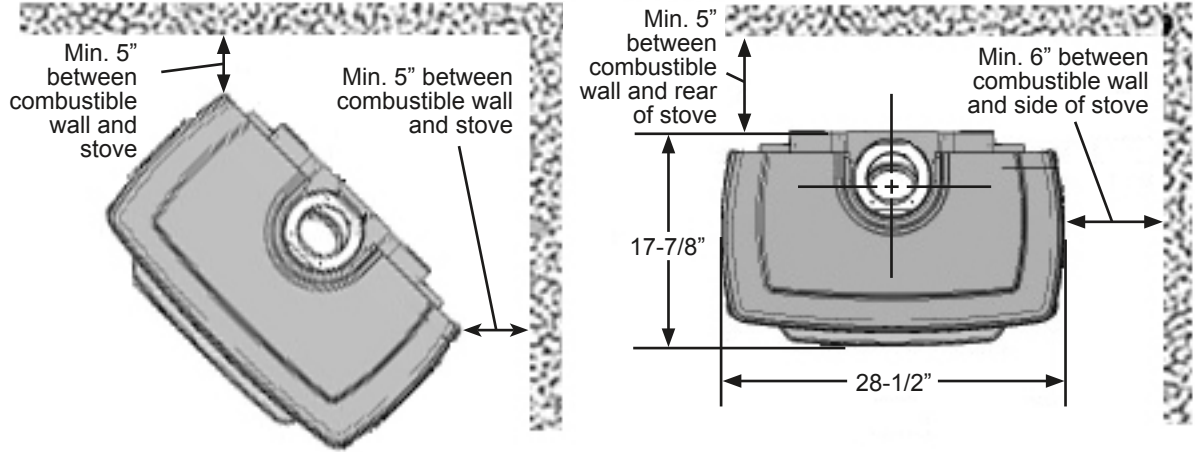

Corner clearances

Wall clearances

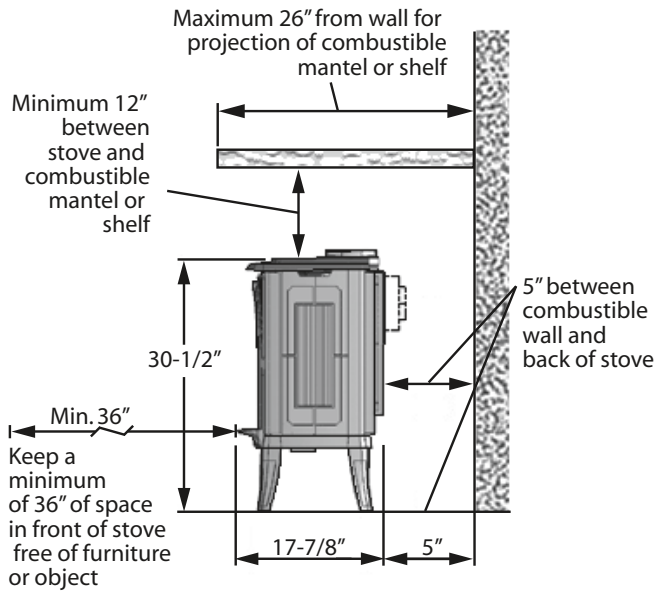

Mantel / shelf clearances

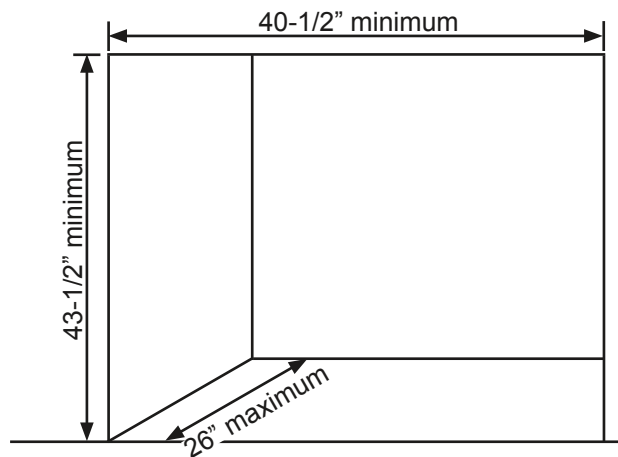

Alcove clearances

Venting

Top / Rear Outlet

This unit is shipped with a top outlet collar which is field-convertible to rear outlet—see page 20 for details.

Vent Material

This unit is approved for installation using 4" x 6-5/8" co-axial direct vent pipe and accessories manufactured by Simpson Dura-Vent, Security and Selkirk—see list of approved venting pipes and accessories on pages 34–35.

This unit may also be converted to co-linear (2–3") venting (**rear vent only**) for use in solid-fuel burning fireplaces and chimneys using adapters and accessories—see list of approved venting pipes and accessories on pages 34–35. Instructions for co-linear conversion are packaged with the co-linear adapter.

Do not mix components from different vent manufacturers, with the exception of Valor's 551DVK Horizontal Termination Kit which can be used in combination with approved manufacturers' venting pipes listed on pages 34–35. Follow the installation instructions supplied with the individual venting components.

Wall Thickness

The appliance vent is suitable for penetrating a combustible wall assembly up to 14" (36 cm) in thickness. A non-combustible wall can be of any thickness up to the maximum horizontal run of vent pipe allowed for the particular installation.

Framing Vent in Combustible Walls & Ceilings

When penetrating through combustible walls and ceilings, frame a minimum of 10" x 10" opening to ensure that the insulation is kept clear of the vent pipe. Also, seal all joints between the wall plates, the wall and the vent pipe. Follow the installation instructions supplied with the individual venting components.

Align the vent center to the center of the frame

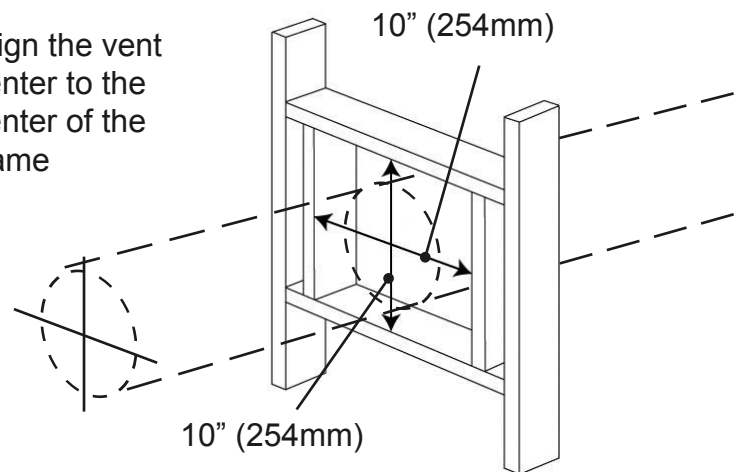

Important Installer Notice – Weather Sealing & Vapor Barriers

It is the installer's responsibility to ensure that vent installations through exterior walls are caulked and weatherproofed in such a manner as to:

- Prevent rain water from entering the wall from the weather side by adequately caulking the outer vent plate to the exterior wall surface.
- Prevent moisture inside the home from penetrating into the wall structure by ensuring the inside wall plate is adequately sealed to the inside vapor barrier.
- Prevent rain water and moisture from entering the walls by sealing the joints between the outer vent tube and the inner and outer wall plates.

We recommend the use of a high quality polyurethane sealant.

Venting

Typical Venting Components

See list of approved venting pipes and accessories on pages 34–35.

Maximum pipe length:
 24" (straight out with snorkel)
 14" (45° elbow out with snorkel)

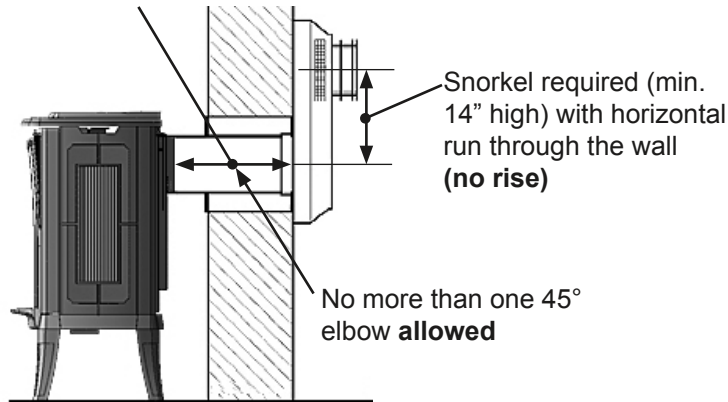

Through wall (without vertical rise)

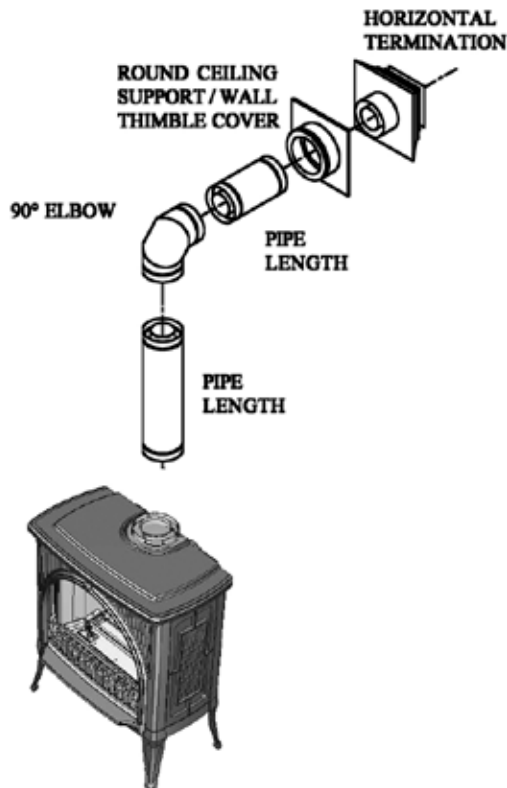

Through wall (with vertical rise)

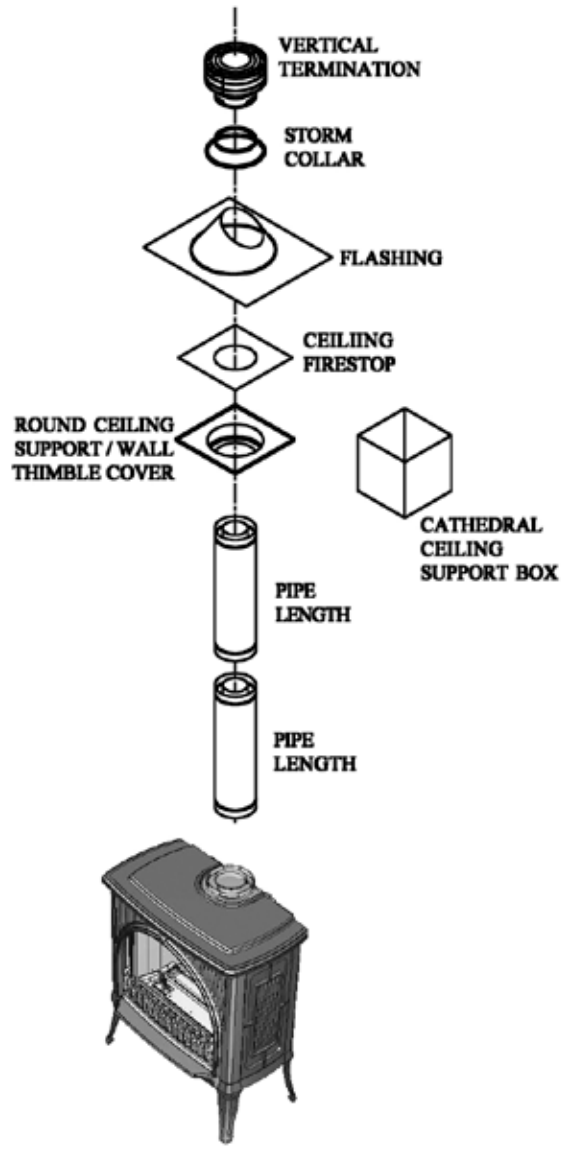

Through roof

Venting

The chart below applies to top or rear outlet, roof or wall termination **with a vertical rise**. **All rear outlet venting without a vertical rise must be terminated by a snorkel.**

How to Read the Venting Chart

1. The total length of the vent pipe cannot exceed 40' (12.2m).
2. The minimum vertical height with roof termination is 8' (2.45 m).
3. Any combination of rise and run can be used as long as they are within the allowable limits shown on the chart below.
4. A maximum of 5 x 90° elbows—or equivalent ($2 \times 45^\circ = 90^\circ$)—can be used.
5. Each 90° elbow installed on the horizontal plane is equivalent to a 3' horizontal pipe; therefore, 3' must be subtracted from allowable horizontal run. (45° elbow is equivalent to 18" horizontal pipe.)
6. All horizontal pipe runs must be graded 1/4" per foot upwards in the direction of the exhaust flow.
7. **Co-linear rear venting** in existing chimney systems is limited to 40' vertical rise.
8. **Restrictors are not required** for co-linear installations.

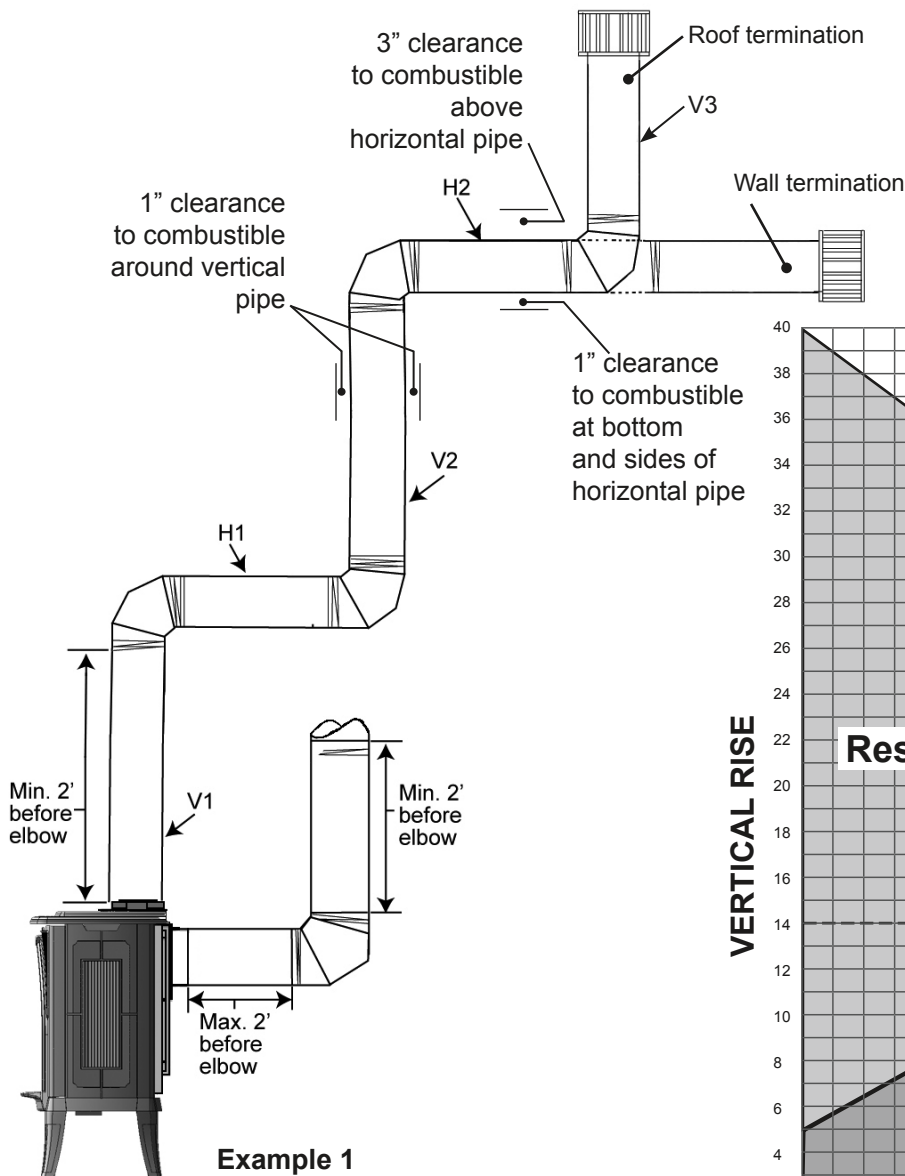

Example 1
 $V \text{ Value} = V1 (6') + V2 (6') + V3 (2') = 14'$
 $H \text{ Value} = H1 (3') + H2 (3') = 6'$
75% restrictor required

Not to scale

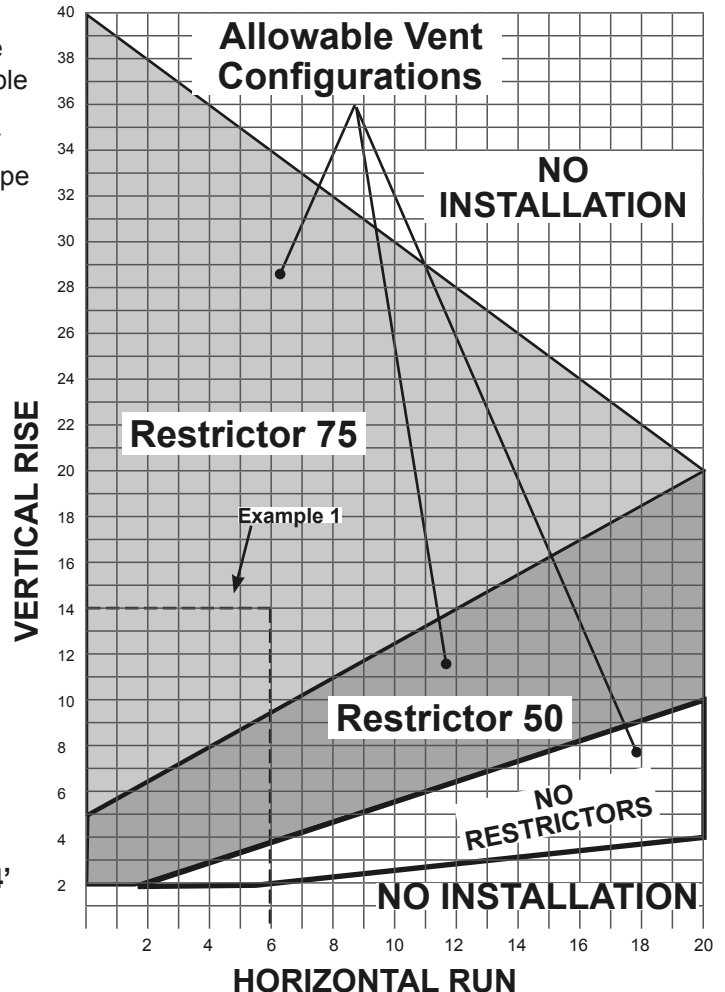

Venting

Restrictors **SOME INSTALLATIONS REQUIRE RESTRICTORS.** For improved flame picture and performance, this unit is supplied with two different sets of vent restrictors. The level of restriction required depends on the vertical rise in the venting system and, to a lesser degree, the horizontal run and number of elbows.

The amount of restriction is based on laboratory tests. The ideal restrictor position may vary slightly, especially when the vent pipe length is near the limits of the acceptable configurations for each type of restrictors.

The chart on the previous page shows the vent restrictor required relative to the length of the vent pipe. Restrictors are not required for co-linear applications.

To install restrictors:

1. Remove every second screw from the exhaust ports in the top of the firebox.
2. Install the restrictors with the removed screws.

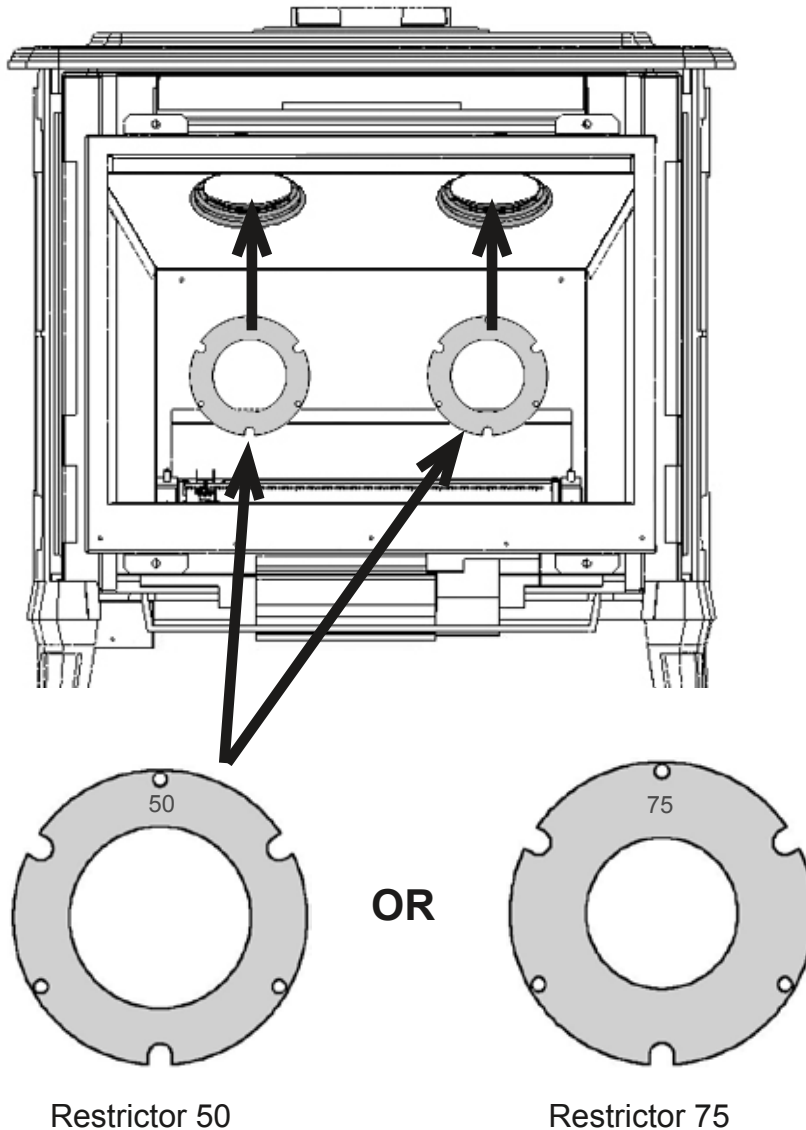

Venting

Horizontal Vent Termination

- The vent terminal must be located on an outside wall or through the roof.
- This direct vent appliance is designed to operate when an undisturbed airflow hits the outside vent terminal from any direction.
- The minimum clearances from this terminal that must be maintained when located on an outside wall are shown in the figure below. Any reduction in these clearances could result in a disruption of the airflow or a safety hazard. Local codes or regulations may require greater clearances.
- The vent terminal must not be recessed into a wall or siding.
- The vent terminal should be positioned where it will not be covered by snowdrifts.
- Sidewall vent terminations within 7' of grade require a terminal guard when using a 551DVK.

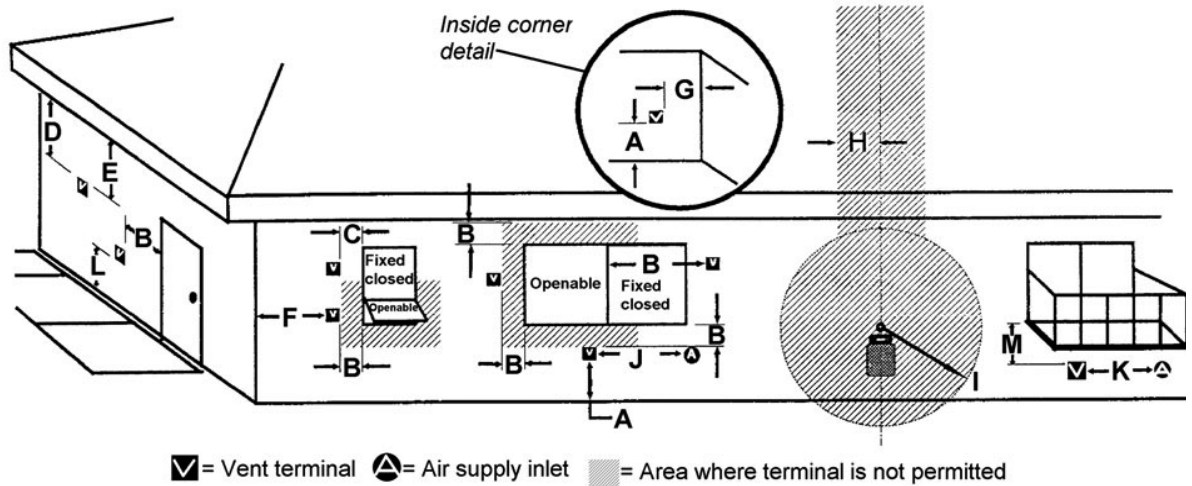

KEY	VENT TERMINAL LOCATIONS - MINIMUM DISTANCES	MINIMUM CLEARANCE	
		Inches	Cm
A	Clearance above grade, verandah, porch, deck or balcony	12	30
B	Clearance to window or door that may be opened	12	30
C	Clearance to permanently closed window (recommended to prevent condensation on window)	12	30
D	Vertical clearance to ventilated soffit located above the terminal within a horizontal distance of 2 feet (60 cm) from the center-line of the terminal	18	46
E	Clearance to unventilated soffit	12	30
F	Clearance to outside corner	12	30
G	Clearance to inside corner	12	30
H	Horizontal clearance to center-line of meter/regulator assembly located within 15 feet (4.6 m) below the terminal	36	90
I	Clearance to service regulator vent outlet	36	90
J	Clearance to non-mechanical air supply inlet to the building or the combustion air inlet to any other appliance	12	30
K	Clearance to a mechanical air supply inlet	72	180
L	Clearance above paved sidewalk or a paved driveway located on public property Note: A vent must not terminate directly above a sidewalk or paved driveway, which is located between two single-family dwellings and serves both dwellings	84	210
M	Clearance under a verandah, porch, deck or balcony <i>Only permitted if veranda, porch, deck or balcony is fully open on a minimum of 2 sides beneath the floor</i>	12	30

Note: Local codes and regulations may require different clearances.

Venting

Vertical Vent Termination

Roof Pitch	Minimum "H" (feet)
Flat to 7/12	1'
Over 7/12 to 8/12	1.5'
Over 8/12 to 9/12	2'
Over 9/12 to 10/12	2.5'
Over 10/12 to 11/12	3.25'
Over 11/12 to 12/12	4'
Over 12/12 to 14/12	5'

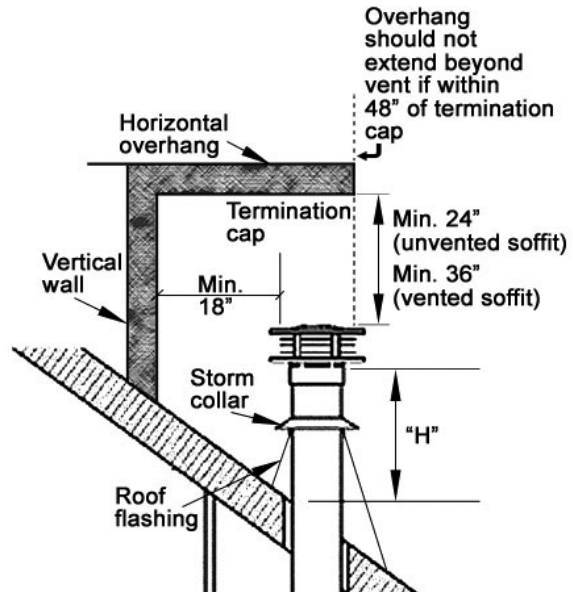

Installation

Fan (Blower)

Allow for and install electrical wiring if there will be a blower to install. Ask the homeowner if you are not sure.

Venting Configuration

This unit is supplied with a **top outlet** and is field convertible to a **rear outlet**. Plan routing of vent taking into consideration stove and vent clearances, allowable vent terminal locations **BEFORE** cutting a hole in the roof or wall. Avoid penetrating the wall/roof at structural members.

Gas Line Routing

Consider visibility of shut-off valve or step-down regulators, etc. when planning gas line routing.

Packs Contents—Appliance & Castings

The Madrona Stove is supplied in three (3) cartons.

- In one carton is the engine.
- In a second carton are the casting sides, the top and the legs.
- In a third carton are the casting front and base.

Unpack the cartons carefully. **We strongly recommend that you leave the engine sitting on the packaging base in which it came to avoid damaging the control valve, wires and pipes already attached to the engine.**

WARNING!
LEAVE ENGINE ON
PACKAGING BASE to
avoid damage to the
control valve, wires
and pipes.

Some parts are packed in the cardboard sleeve around the engine; make sure you take them all out of the packaging. The engine carton contains a list of all components included in the three cartons. Make sure you have all the components before you start the installation.

Appliance Preparation

Window & Log Pack

1. Release the spring bolts at top and bottom of the window by pushing and turning 1/4 turn.
2. Lift the window and set it aside in a safe place to avoid damage.
3. Remove the log pack from inside the firebox and set it aside with the window. Please handle the logs carefully as they are made of fragile material and can easily be damaged.

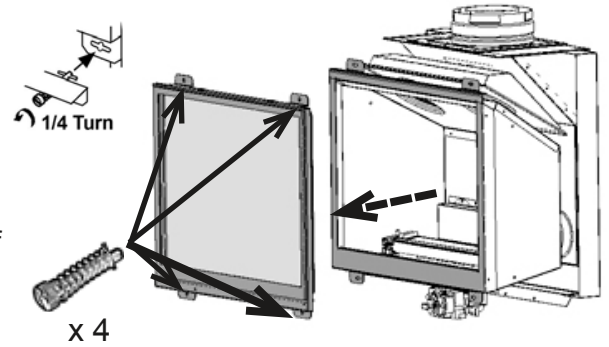

Casting Base

1. Rough-in the gas line and electrical wiring for a fan (if any).
2. Decide where the stove should be positioned to avoid moving it once all the casting pieces are attached together.
3. Place the casting base upside down. Unscrew the bolts to insert the legs.
4. Slide each leg under the head of its bolt.
5. Tighten the bolts securely with a wrench.

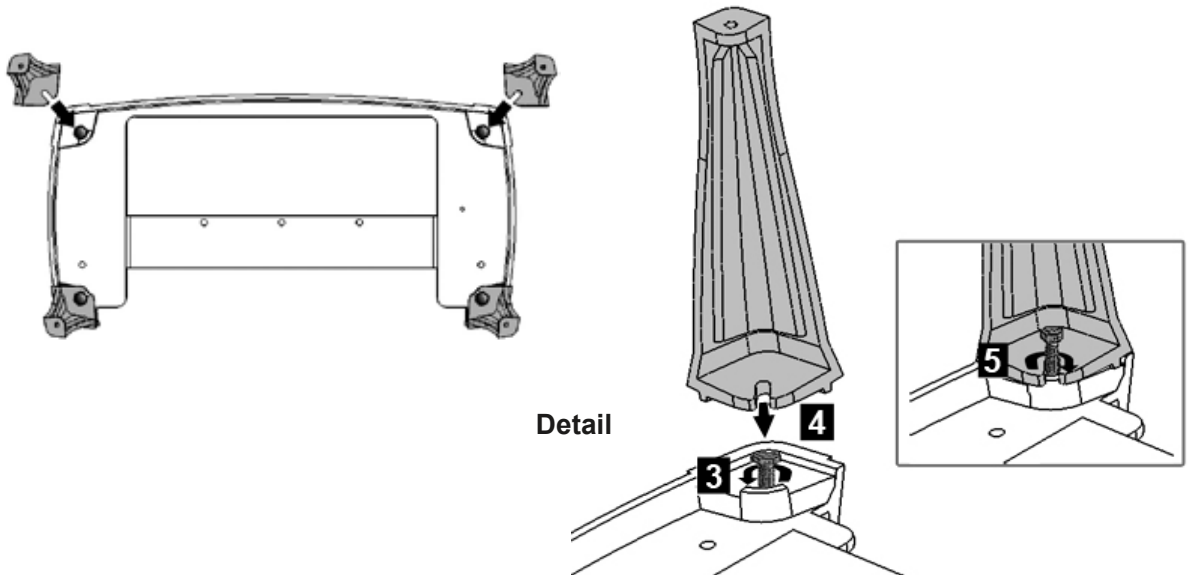

6. Fix the casting base to the floor or hearth using bolts (not supplied) through the casting feet—see the bolting pattern below. **(Required for mobile homes only).**

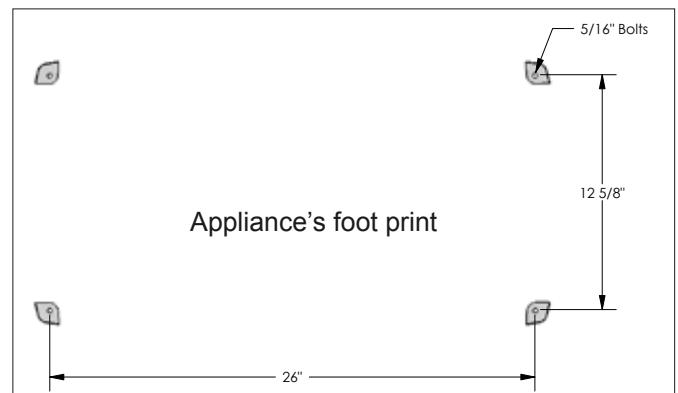

Appliance Preparation

Engine Flip the base upside-down. Place the engine on the base at its approximate final position—see detail below. Center the engine using the holes at front of the base as guidelines.

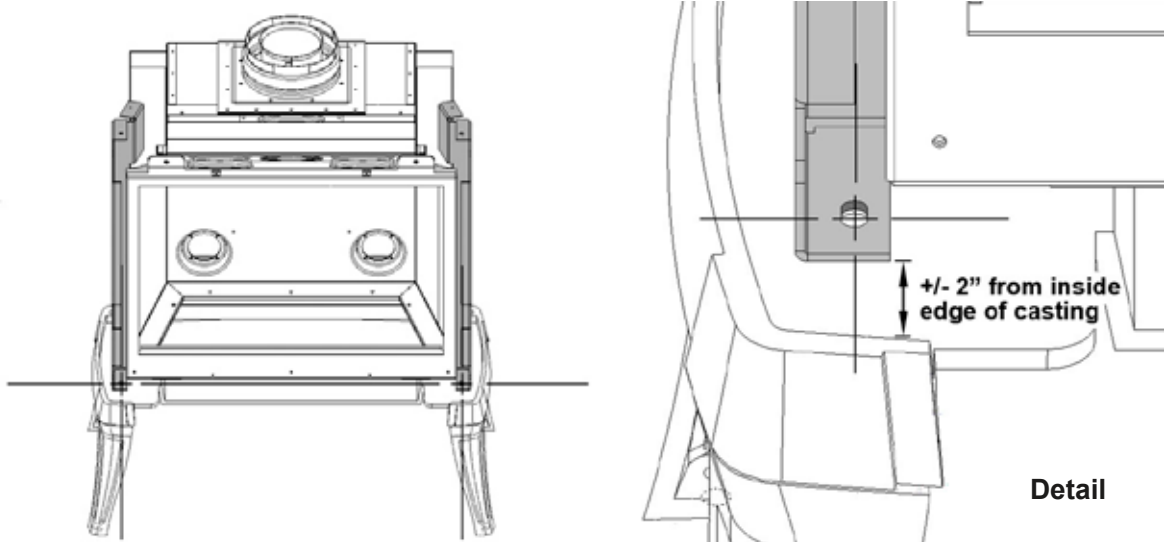

Casting Side Panels

On the casting side panels, release the top and bottom screws.

1. Drop a hinge pin on the back corner of base and drop the side panel on the pin.
2. Rotate the panel towards the engine.
3. Repeat with the other casting side panel.

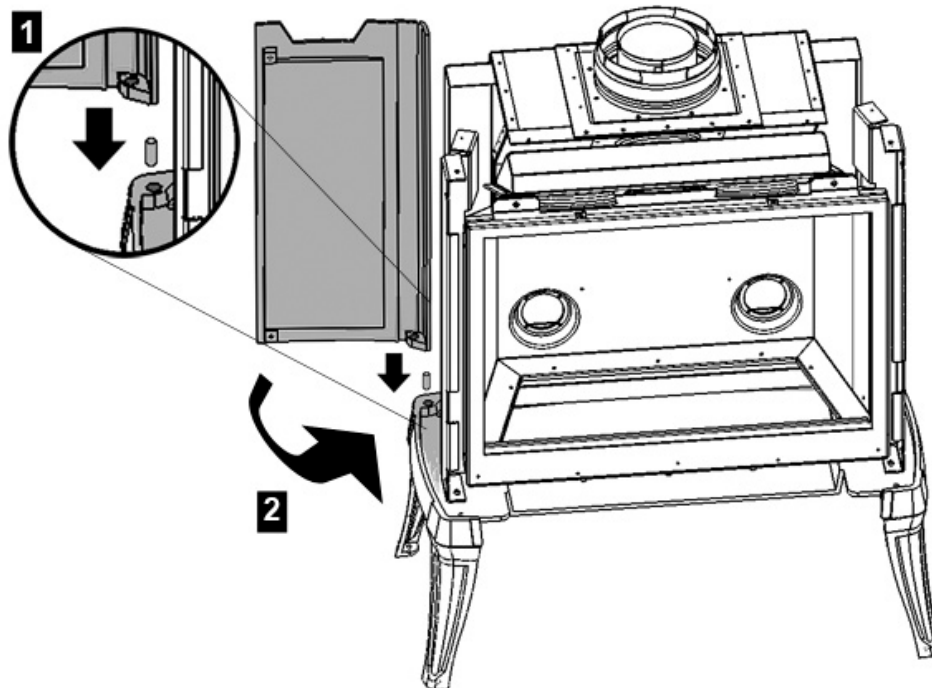

Appliance Preparation

Fixing Casting Side Panels & Engine

1. Adjust the position of the engine to locate the top and bottom screws of the side panels into the slots of the engine's side bracket. Tighten the top and bottom screws.
2. Adjust the engine as required and fix it to the casting base at bottom of its side brackets with the nuts and bolts provided.

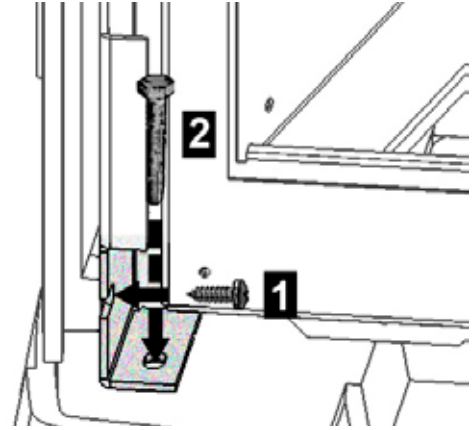
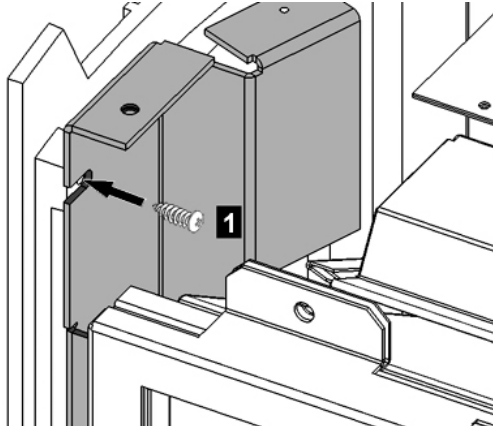

Lighting Instructions Plate

The lighting instructions plate is attached to the back of the engine and may have slid out of its slot. Reposition the plate if this is the case.

Remote Control Receiver

Under the engine, the receiver box is clipped to the burner pipes to facilitate transportation. Unclip the box and let it hang while you fit the gas pipe.

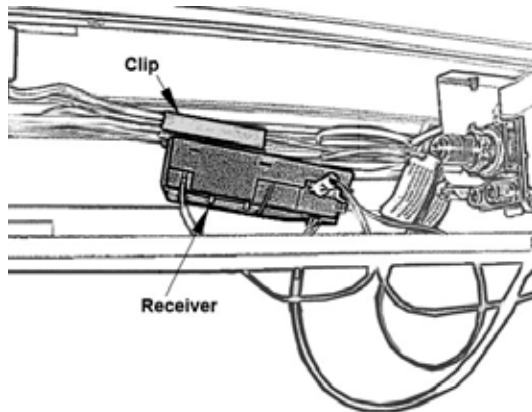

Receiver hooked to burner pipes

Gas Pipe & Connector

Fit the pipe and connector supplied with the engine to the valve. Connect the gas line to the inlet pipe.

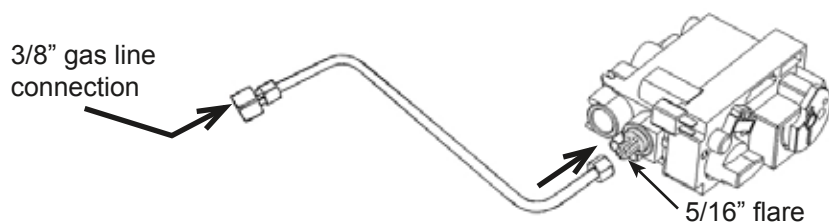

Appliance Preparation

Receiver Position

Once the gas pipe is fitted, clip the receiver **on top** of the casting crossbar on the base, to the left hand side of the valve. Make sure the receiver box is oriented with its wires towards the back and its sensor at the front.

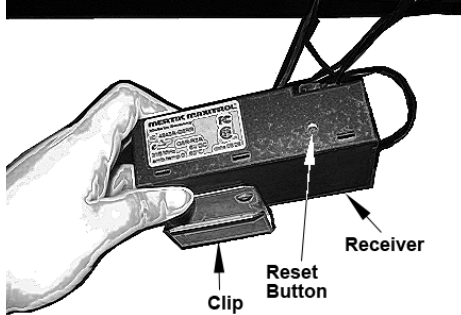

Receiver & clip

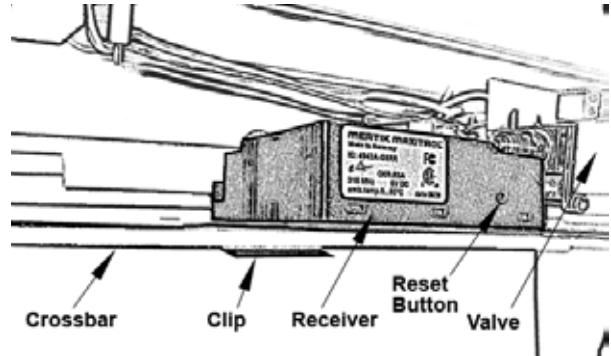

Receiver clipped to crossbar in final position

Optional Fan (Blower)

If the Circulating Fan Kit (blower) is to be installed, we suggest that you do it now.

1. Take the fan out of its package.
2. Remove the mounting plate from the fan and discard it.
3. Position the fan in such a way that its exhaust is directed upwards, towards the space between the inner and the outer walls of the firebox.

NOTE: You may need to remove the burner to access the back of the stove. If this is the case, first remove the rear log support (NG/LPG) and the front log support (LPG), and then, the burner.

4. Using 3 screws, fix the fan to the firebox bracket.
5. Fix the fan control box bracket provided to the control box with 2 screws.
6. Fix the bracket, with the control box attached, to the casting base of the stove from underneath.
7. With 2 screws from the burner plate, fix the fan's thermoswitch to the underside of the burner plate, behind the pilot area.
8. See instructions with the 555CFK kit for complete details.

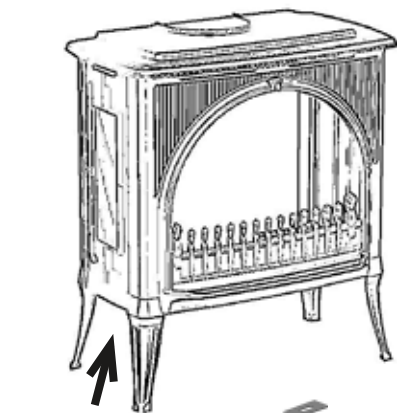
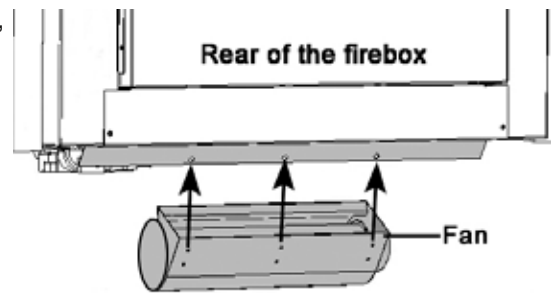

Fan control box position



Fan control box bracket

Fasten Thermal Switch to underside of burner module using 2 existing screws

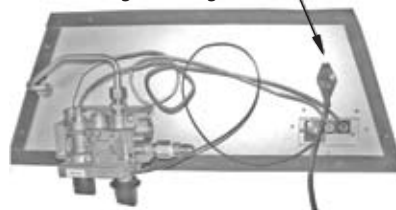

Appliance Preparation

Venting Outlet

If the appliance is to be vented from the **top**, it is ready for vent installation once the engine is on the casting base.

If the appliance is to be vented from the **rear**, it must be converted. Follow these simple steps:

1. Remove the following parts in this order:
 - a. Dura-Vent collar, gasket and intake plate from the top of the appliance (22 screws of the intake plate and 2 rear screws of the collar);
 - b. Exhaust collar (8 screws).



NOTE: The gaskets are glued to the engine or the intake plate; it is not necessary to separate them from the parts they are attached to. However, if they need to be manipulated, **BE CAREFUL not to damage them because their material is fragile.**

2. Re-install through the vent opening at the rear of the firebox in the reverse order in which you took the parts out.

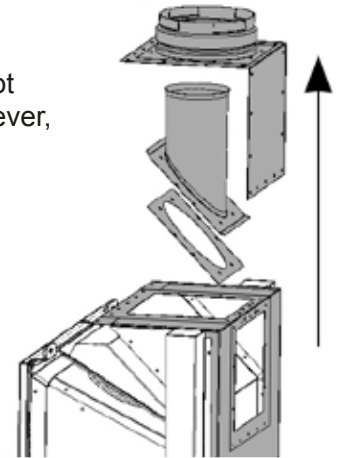
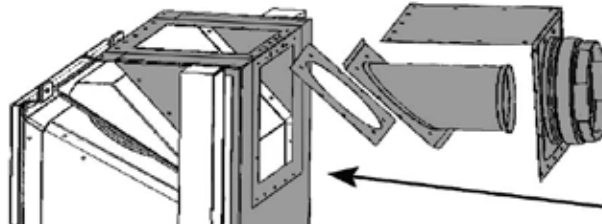

Co-linear Applications

For conversion of top or rear outlet collars to co-linear (2 x 3") rear venting, refer to instructions packaged with the 556CLA Co-linear Adapter.

NOTE: Co-linear venting may only be installed into solid-fuel burning fireplaces and chimneys.

Top Spar

1. Position the top spar on the side brackets located between the engine and the cast sides.
2. Fix the spar with four 3/8" pre-assembled screws provided.

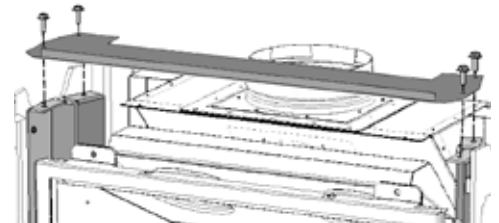

Supply Gas

- Connector**
- The gas supply inlet connection is a 3/8" NPT female connector. For detailed location of this connector see drawing on page 7. If a circulating fan or isolating valve is to be installed, adjust the routing of the gas line to suit.
- Pipes**
- Use only new black iron or steel pipes or copper tubing if acceptable—check local codes. *Note that in USA, copper tubing must be internally tinned for protection against sulfur compounds.*
- Unions**
- Unions in gas lines should be of ground joint type.
- Supply Line Size**
- The gas supply line must be sized and installed to provide a supply of gas sufficient to meet the maximum demand of the appliance without undue loss of pressure.
- Sealant**
- Sealant used must be resistant to the action of all gas constituents including LP gas. Sealant should be applied lightly to male threads to ensure excess sealant does not enter gas lines.
- Manual Shut-off Valve & Union**
- The supply line should include a **manual shut-off valve** and **union** to allow the appliance to be disconnected for servicing.
 - Pressure test the supply line for leaks.
- Test Pressures >1/2 psig (3.5kPa)**
- The appliance and its individual shut-off valve must be disconnected from the gas supply piping system during any pressure testing of that system at test pressures in excess of 1/2 psig (3.5kPa).**
- Test Pressures ≤1/2 psig (3.5kPa)**
- The appliance must be isolated from the gas supply piping system by closing its individual manual shut-off valve during any pressure testing of the gas supply piping system at test pressures equal to or less than 1/2 psig (3.5kPa).**
- Possible Damages**
- Failure to either disconnect or isolate the appliance during pressure testing may result in regulator or valve damages and void the warranty. Consult your dealer in case of damages.
- Minimum Pressure**
- The minimum supply pressure is given in the Ratings section of this manual—page 7.
- Leak Test Mandatory**
- All piping and connections must be tested for leaks after installation or servicing. All leaks must be corrected immediately.
 - When testing for leaks:
 - Make sure that the appliance is turned off.
 - Open the manual shut-off valve.
 - Test for leaks by applying a liquid detergent or soap solution to all joints. Bubbles forming indicate a gas leak.**Never use an open flame to check for leaks.**
Correct any leak detected immediately.
- Test Tapping Location**
- The pressure test tapping locations are shown in the figure above. A built-in non-adjustable regulator controls the burner manifold pressure. The correct pressure range is shown in the table in Ratings section of this manual on page 7. The pressure check should be made with the burner alight and at its highest setting. See lighting instructions section for full operating details on page 31.

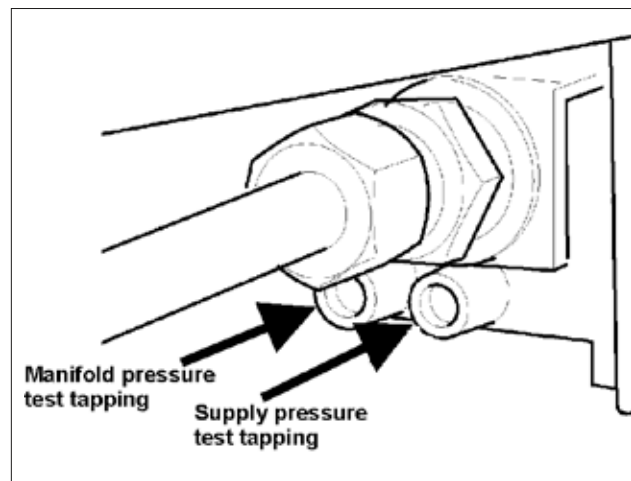

Ceramic Logs

The ceramic logs are supplied in two packages. Unpack them very carefully to avoid damaging the fragile material. Install the logs as shown below. **Please note that the Rear and Front Logs will have a different position depending of the gas type. The position of the Logs is critical to insure the good performance of the appliance.**

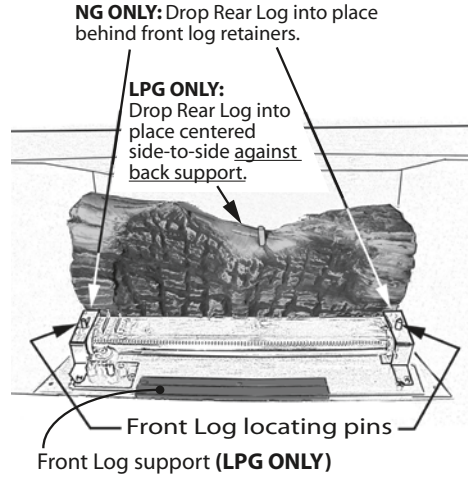

1

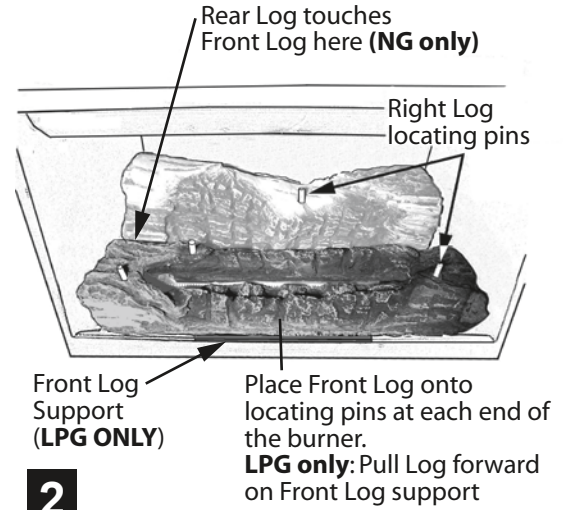

2

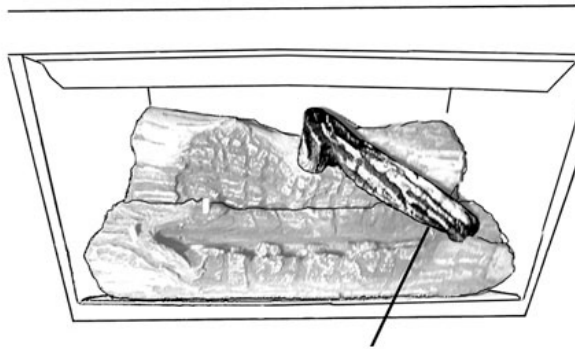

3

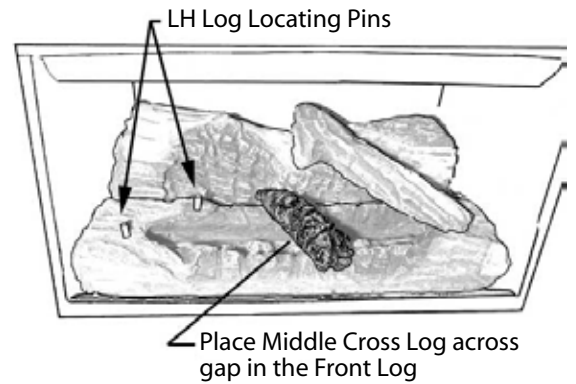

4

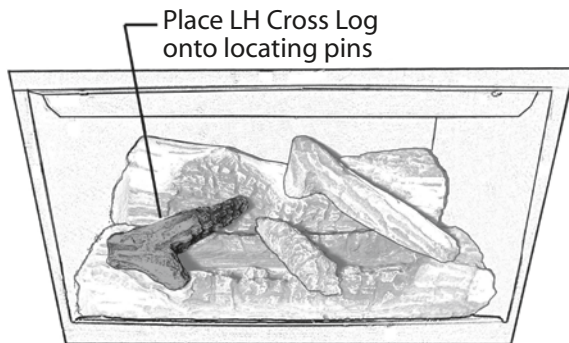

5

Window Refitting

To refit the window, place it on the firebox frame and hold it in place while pushing and turning its fastening studs 90 degrees.

Then, apply light hand pressure against the window frame sides to bed-in the window seal.

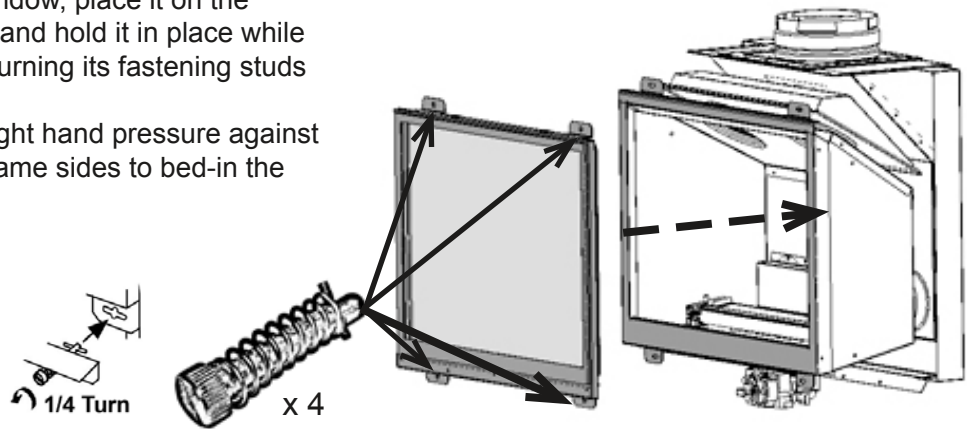

Initial Remote Control Set-up

The receiver and the handset of the remote control system must be initially synchronized before the first use.

1. Insert batteries in the remote control receiver and handset. The receiver is located left of the control valve under the burner module.
2. With a sharp object, press and hold the receiver's reset button until you hear two (2) acoustic signals. After the second, longer acoustic signal, release the reset button.
3. Within the subsequent 20 seconds, press the  (small flame) button on the remote handset until you hear an additional long signal confirming the synchronization is set.

This is a one time setting only and is not required when changing the batteries in the remote receiver. The remote control system is now ready to use.

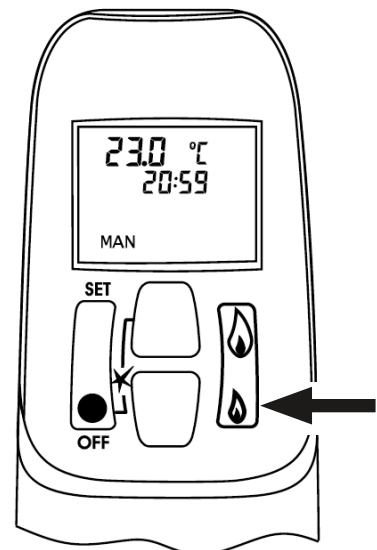
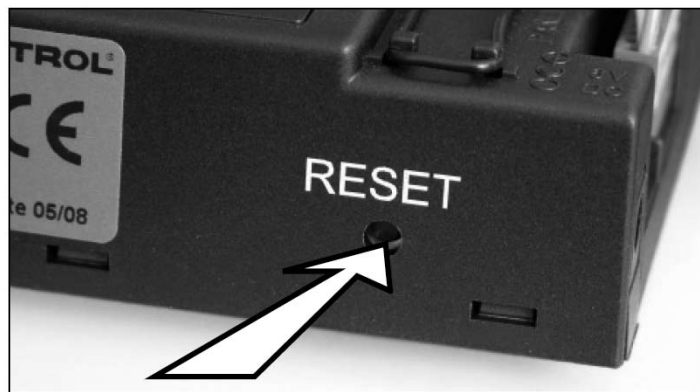

Operation Check & Aeration Settings Adjustment

Operation Check Turn the fireplace flame up and down using the remote control to confirm that the full range of inputs is achieved—see the remote control operation instructions on pages 27–29.

Aeration Settings Light the fire and allow the unit to warm up for 10–15 minutes to evaluate the flame picture. The burner is equipped with an adjustable shutter to control primary aeration. See the figures below. The shutter is factory-set to an aeration gap which will give optimum performance for the vast majority of installations. In a few unusual installations, the flame picture may be improved by adjusting the aeration. The need for adjustment should be determined only by operating the appliance with the ceramic logs and window installed.

Increasing aeration will cause the flames to appear more transparent and blue making the ceramic logs glow more.

Decreasing aeration will cause the flames to appear more yellow or orange making the ceramic logs glow less.

Too little aeration may result in black carbon forming and dropping into the firebox.

Air Shutter

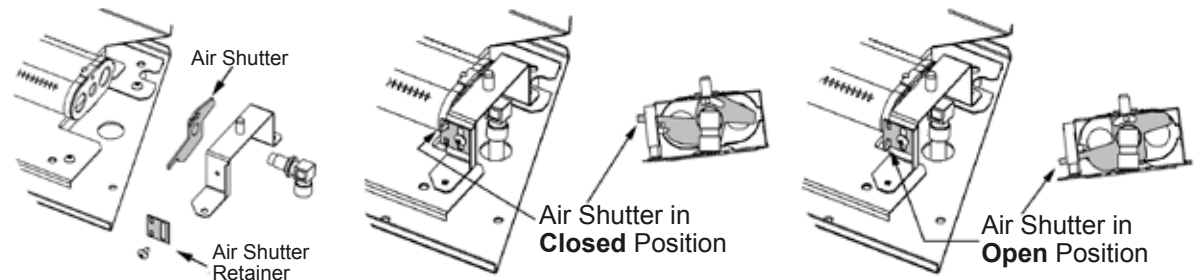

Front & Top Installation

Front Installation Hook the cast front to the side brackets located between the engine and the cast sides.

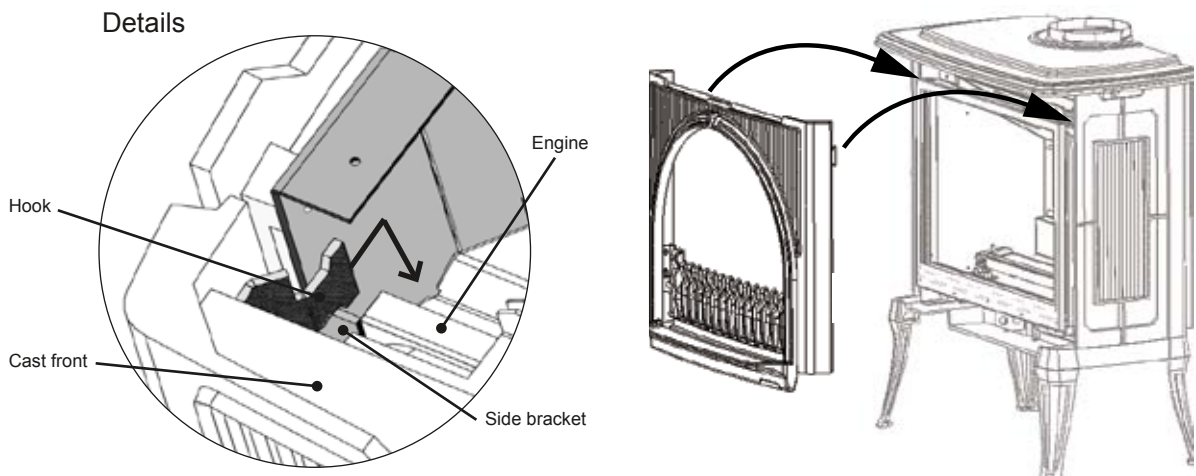

Front & Top Installation

Top Casting

Place the top casting piece on the top of the stove ensuring the rear edge is flush with the rear edge of the cast side panels. Fill in the vent space with the infill plate if using a rear vent. To level the top casting, unscrew the levelling bolts on the top rear of each casting side panel as appropriate

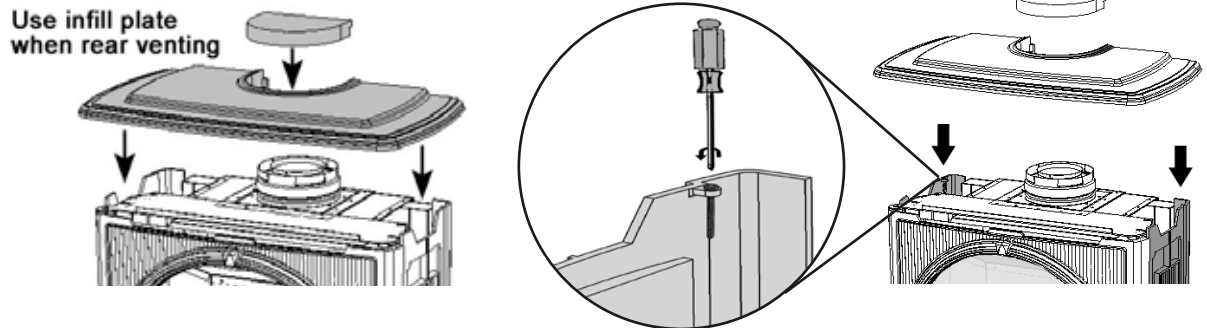

Removeable Fret

To access the gas valve and the remote control receiver, the fret can be removed without removing the front casting. Once **the stove has cooled down and with extra care not to hit the glass of the window**, simply slide the fret out of its brackets, angle it up and remove it. To put it back in place, proceed in the reverse order.

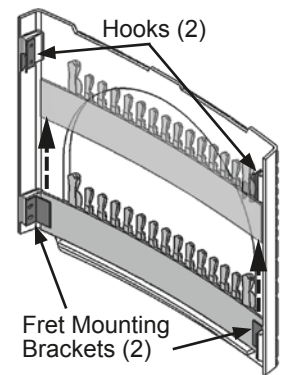

Remote Control Handset Wall Holder Installation

The remote control kit for this fireplace comes complete with a wall-mounted holder. This holder is not required in all installations but is provided as an optional feature for those customers who wish to mount the remote handset to the wall.

To install the holder to the wall, find a convenient location and use the hardware provided with the kit. See the diagram for required hardware and configurations. Note that the holder can be installed at the base of a light switch plate.

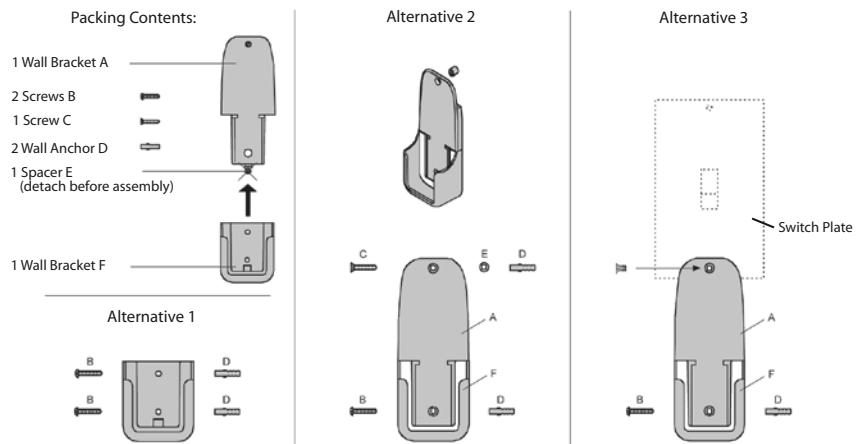

IMPORTANT. The location of the remote control handset is important to assure proper temperature regulation. To obtain a constant temperature, we recommend that the handset should be between 3 and 15 feet away from the appliance **but not directly above it**. We also advise that the handset should be located away from any other heat source and not in direct sunlight as this may affect the temperature sensor located in the remote handset.

Owner's Information

Operating Your Stove

For your safety, this appliance is fitted with a flame supervision device which will shut-off the gas supply if, for any reason, the pilot flame goes out. This device incorporates a fixed probe, which senses the heat from the pilot flame. If the probe is cool, the device will prevent any gas flow unless the MAN knob is in position MAN and the metallic core on the valve is pushed in. See full lighting instructions on page 31 of this manual.

WARNING: Your stove becomes very hot when operating. Avoid placing decorative objects sensitive to heat on the stove or within 36" around it.

Cleaning

It will be necessary to clean the glass periodically. During startup, condensation, which is normal, forms on the inside of the glass and causes dust and lint to cling to the glass surface. Initially, paint, while curing, may deposit a slight film on the glass. We therefore recommend that, during the first few weeks of use, the glass be cleaned two or three times with non-abrasive common household cleaners (such as dish soap) and warm water.

Ammonia based cleaners should NOT be used.

Subsequently, the glass should be cleaned two or three times a season depending on the circumstances. Do not clean the glass while it is hot. Always securely replace the window before lighting. **If broken, the glass pane may only be replaced as a complete window unit as supplied by the manufacturer.**

To remove the window for cleaning, rotate its four fastening studs 90 degrees to release and gently pull the window unit outwards—see page 16. Set aside in a safe place to avoid damage.

To refit the window, place it on its frame and hold it in place while pushing and turning its fastening studs 90 degrees. Then, apply light hand pressure against the window frame sides to bed-in the window seal—see page 23.

Dust can be brushed from the ceramic logs and firebox walls after removing the front unit and opening the window. Dust can also be removed from the burner using a soft brush after removing the ceramic logs. When cleaning, make sure that no particles are brushed into the slots of the burner.

Checks

Performance of LPG appliances may be affected by the quality of commercial gas supplied in your area.

A periodic check of the pilot and burner flames should be made. Check after the fire has been on for at least 30 minutes. The pilot flame must cover the tip of the thermocouple probe. The main burner flame pattern will vary from appliance to appliance depending on the type of installation and climatic conditions.

The appliance area must always be kept clear and free from combustible materials, gasoline and other flammable vapors and liquids.

Inspect the vent terminal outdoors regularly to make sure that snow, trees, bushes, leaves, or other objects do not obstruct it.

Examine the vent system and terminal regularly. We recommend annually.

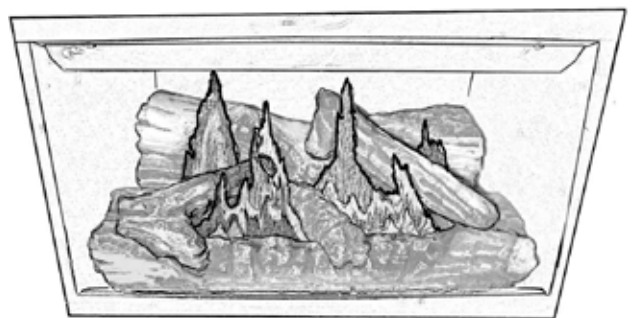

Correct Flame Picture

Owner's Information

Batteries The appliance uses four 1.5 V AA batteries for its remote control receiver and one 9 V battery for its handset. Batteries should last one to two seasons, depending on usage. Removing the batteries in the off-season will extend the battery life. Should the batteries lose power, the control may be operated by manually turning the control knob at the valve or by turning off the valve at the switch.

To replace the batteries in the remote control receiver, carefully pull the receiver off its *Velcro* attachments on the cross beam.

Touch Up Paint If you need to touch up the paint on your cast unit, use the Stove Bright by Forrester 1990 Satin Black spray paint. Please note that it may be necessary to spray the entire cast piece.

Servicing If any attention is required for your appliance, contact your supplier quoting the model number. It will be helpful if the appliance serial number can also be quoted. This number is on the rating plate, which is attached to the unit. The replacement parts are shown at the end of this manual. Please always quote the part number and description when requesting spare parts.

Remote Control Operation **NOTE: Before using the remote control system for the first time, the receiver and the handset must be synchronized. See the section *Initial Remote Control Set-up* on page 23 in this manual.**

Your fireplace remote control helps you get the comfort, convenience and aesthetics you want from your gas fireplace. The remote controls your fireplace in different ways.

IMPORTANT: BEFORE YOU BEGIN, please note that on this system, the settings of time, temperature and automatic ON/OFF **can only be programmed when the function display is flashing**. Be patient when programming as it can take a few seconds to set.

Turning Your Fireplace ON

WARNING: When the pilot is lit, the valve motor turns automatically to maximum flame height.

1. Make sure that the MAN knob on the valve is in ON position.
2. Make sure that the switch on the valve is in the I position.
3. Press and hold the OFF and  (large flame) buttons until you hear a short acoustic signal. Release the buttons.

The acoustic signals will continue until the pilot lights. The remote control will go automatically into TEMP mode. The flame will be at maximum height until the remote control reads the temperature (factory set) and will then adjust the flame accordingly.

You can put the remote in MAN manual mode, change the temperature in TEMP mode or program your remote in TIMER mode as indicated in the following sections.

Turning Your Fireplace OFF

1. Press the  (small flame) button to reduce the flame to pilot.
2. Press the OFF button to turn the pilot off.

Alternately, you can press the **O** button on the switch if you won't use your fireplace for a long period of time, if you cannot locate your remote control handset or if you wish to change the batteries.

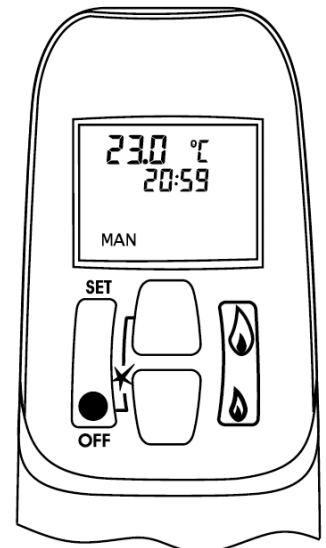

Owner's Information

Operation Modes

STANDBY MODE—Ignited pilot only.

MAN MAN MODE—Manual Mode. You can use this mode to adjust the flame height up or down.

☼ **TEMP TEMP MODE**—Daytime Temperature Mode (appliance must be in Standby mode; pilot ignited): The room temperature is measured and compared to the set temperature. The flame height is then automatically adjusted to achieve the Daytime set temperature.

☾ **TEMP TEMP MODE**—Nighttime Setback Temperature Mode (appliance must be in Standby mode, pilot ignited): The room temperature is measured and compared to the Nighttime Setback temperature. The flame height is then automatically adjusted to achieve the Nighttime Setback temperature.

TIMER TIMER MODE—(appliance must be in Standby mode, pilot ignited): The Timer setting allows you to set two burner ON times and two burner OFF times for every 24-hour period.

Changing the Mode of Operation

Briefly pressing the **SET** button changes the mode of operation in the following order:

MAN → ☼ TEMP → ☾ TEMP → TIMER → and back to MAN

NOTE: MAN mode can also be reached by pressing either the 🔥 or 🔥 buttons.

Mode	Sun ☼	Moon ☾
TEMP	Daytime temperature setting	Nighttime temperature setting
TIMER	Start time setting	Stop time setting

Flame Height

The flame height can be adjusted in the following manners. In STANDBY mode,

1. Press the 🔥 (large flame) button to turn on the main burner.
2. Press the 🔥 (large flame) button to increase the flame height.
3. Press the 🔥 (small flame) button to decrease the flame height or to go to pilot Standby position.

For fine adjustments, tap the 🔥 and 🔥 buttons.

Quick Flame Adjustment

If 🔥 or 🔥 are pressed for 0.5 sec., the flame will increase to maximum or decrease to the pilot Standby position.

NOTE: While pressing either button, a symbol indicating transmission appears on the upper right hand corner of the display. The receiver confirms transmission with an acoustic signal.

Time To set the time, follow the steps below.

1. The display indicates °C/24-hour or °F/12-hour clock. To change from one to the other, press and hold both the **OFF** and 🔥 buttons until the display changes.
2. To set the time, hold down **both** the 🔥 and 🔥 buttons until the display flashes. Let go.
3. Quickly press the 🔥 button to set the hour and the 🔥 button to set the minutes.
Note: You must start setting the time while the display is flashing. If it stops flashing, go back to 2.
4. Press the **OFF** button to return to manual mode or simply wait and it will automatically return to Manual mode.

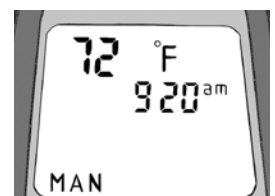

Owner's Information

Temperature

Use this setting when you come in and want to enjoy a set temperature.

1. Select either the **☼ TEMP MODE** or the **☾ TEMP MODE** by briefly pressing the **SET** button.
2. Hold the **SET** button until the **TEMP** display flashes.
3. Set the desired temperature with the **🔥** or the **🔥** buttons.
Note: 4.5°C/40°F is the minimum temperature setting.
4. Press the **OFF** button or simply wait and the display will go to the temperature control mode.
Note: If you would like the Nighttime Setback temperature control to turn off, decrease the **☾ TEMP MODE** setting until [---] appears on the display. Your fireplace will reach the set temperatures and the remote handset will check the temperature every five minutes, adjusting the amount of fuel needed to give you a steady, even heat.
5. The display must remain in **TEMP** mode on the remote handset.

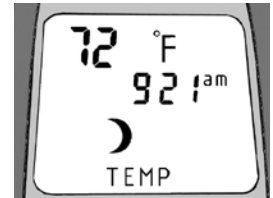

Timer

It is possible to program two periods of time per day at which your fireplace will turn on and off automatically.

For example, you can set your fireplace to turn on in the morning just before you get up (P1 ☼ [start time]) and to turn off when you leave for the day (P1 ☾ [stop time]). Then, you can set your fireplace to turn on again at the end of the day (P2 ☼ [start time]) and to turn off when you go to bed at night (P2 ☾ [stop time]).

If you wish to set only one time period at which your fireplace will turn on and off, program P2 ☼ [start time] and P2 ☾ [stop time] for the same time as P1 ☼ [start time].

1. Select **TIMER** mode by briefly pressing the **SET** button.
2. Press and hold the **SET** button until **TIMER** is displayed on the lower right hand side.
3. Press and hold the **SET** button until P1 ☼ and the time display flashes. Set the start time by pressing the **🔥** button for the hour and the **🔥** button for the minutes. Then, briefly press **SET** to P1 ☾ and set the stop time in the same manner you just set P1 ☼.
4. Briefly press the **SET** button again for the next burner cycle time, which will be P2 ☼ and P2 ☾.
5. Once all four times are set, press **OFF** or simply wait to complete programming.
6. The remote handset must remain in **TIMER** mode to function automatically.

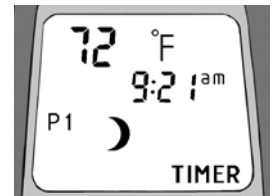

Low Battery Indication

Remote handset: **BATT** will appear on the display when the battery needs to be replaced. Replace with one 9 V battery (alkaline recommended).

Receiver: Three short 'beeps' will sound when the motor turns when the batteries need to be replaced. Replace with four 1.5 V batteries (alkaline recommended).

NOTE: With very low battery, the valve shuts off the fire completely. This does not happen when the power supply is interrupted.

Poor Reception

If the reception is poor, remove the tape from the antenna on the receiver and stretch the antenna toward an open area. This should improve reception.

Handset / Receiver Match

The remote control handset and receiver are programmed to function together. In case of a replacement of the handset or the receiver, you will need to reset the receiver to handset to allow them to function together. Contact your dealer for details

Automatic Standby Mode

If there is no transmission from the handset to the receiver within a 6-hour period, the appliance will go to **STANDBY** (pilot) mode.

Owner's Information

Manual ON/ OFF Switch

In cases where you want to turn off your fireplace and cannot do it with the remote control handset (misplaced, lost, dead batteries, etc.), you can turn off the appliance with the manual switch located on the right hand side of the valve. Simply reach under the front and activate the switch.

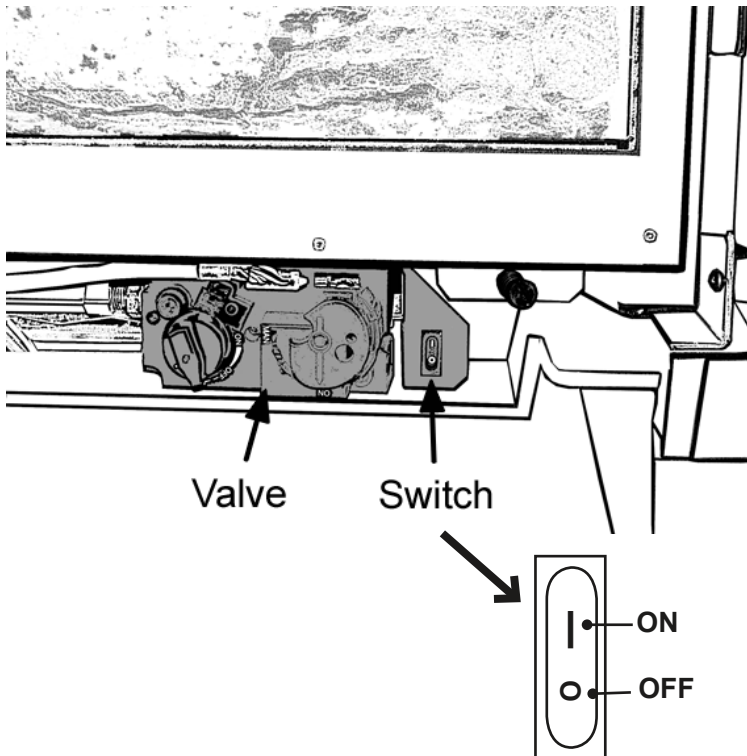
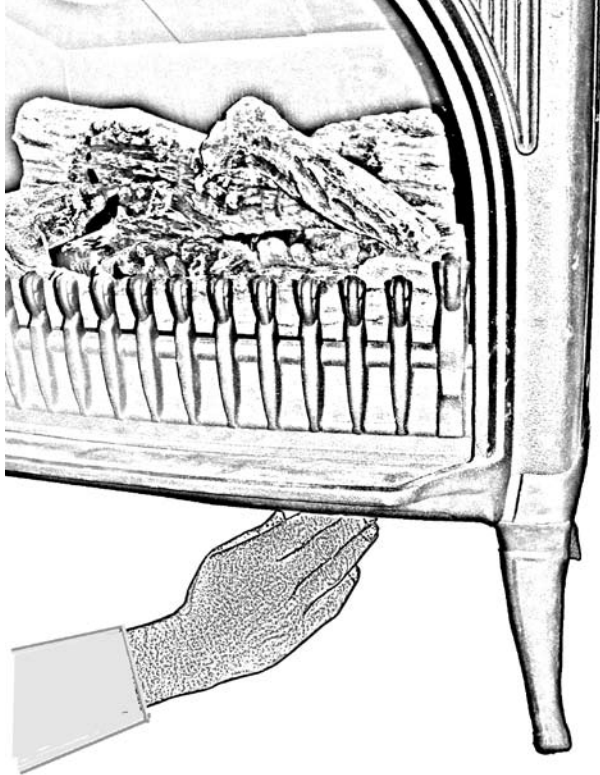

Lighting Instructions

FOR YOUR SAFETY, READ BEFORE LIGHTING

WARNING: If you do not follow these instructions exactly, a fire or explosion may result causing property damage, personal injury or loss of life.

- A. This appliance has a pilot which must be lighted by hand or by remote control. Follow these instructions exactly. To save gas, turn the pilot off when not using the appliance for a prolonged period of time.
- B. **BEFORE LIGHTING**, smell all around the appliance area for gas. Be sure to smell next to the floor because some gases are heavier than air and will settle on the floor.
- WHAT TO DO IF YOU SMELL GAS**
- Do not try to light any appliance.
 - Do not touch any electric switch; do not use any phone in your building.
 - Immediately call your gas supplier from a neighbor's phone. Follow the gas supplier's instructions.
 - If you cannot reach your gas supplier, call the fire department.
- C. Use only your hand to push in or turn the control knobs. Never use tools. If the knobs will not push in or turn by hand, don't try to repair them; call a qualified service technician. Force or attempted repair may result in a fire or explosion.
- D. Do not use this appliance if any part has been under water. Immediately call a qualified service technician to inspect the appliance and to replace any part of the control system and any gas control, which has been under water.

LIGHTING INSTRUCTIONS

1. **STOP!** Read the safety information above.

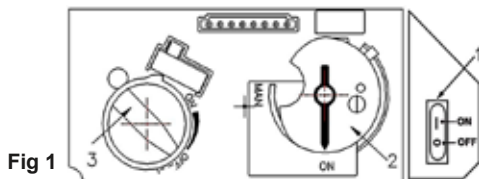

Fig 1

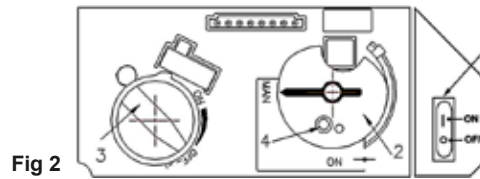

Fig 2

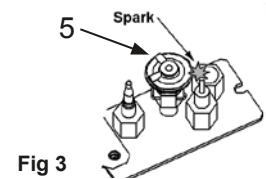

Fig 3

2. **SET ON/OFF SWITCH (1) TO "OFF" POSITION.**

- Wait five (5) minutes to clear out any gas, then smell for gas, including near the floor. **If you smell gas, STOP!** Follow "B" in the safety information above on this label. If you don't smell gas, go to the next step.
3. **AUTOMATIC IGNITION** (Fig. 1): Locate the pilot (Fig. 3.) inside of firebox at left hand side.
- ON/OFF switch (1) in ON position, MAN-knob (2) in ON position; set Flame Adjustment knob (3) to lowest setting (U).
 - On the remote control handset, press the OFF button (red dot) and large flame button (🔥) simultaneously; a short acoustic signal confirms the start has begun.
 - Further short acoustic signals indicate the ignition process is in progress.
 - When the pilot is lit, the Flame Adjustment knob (3) will automatically rotate to the highest setting.
 - Press the small flame button (🔥) on the remote control handset to reduce the flame height.
4. **MANUAL IGNITION** (Fig. 2): With the window off, locate the pilot (Fig. 3) inside of firebox at left hand side.
- ON/OFF switch (1) in ON position, MAN-knob (2) in MAN position.
 - Set Flame Adjustment knob (3) to the lowest setting (U).
 - Push down the metallic core (4) with a pen or similar instrument; this will establish the pilot gas flow.
 - Light gas at the pilot (5) with a match.
 - Continue holding down metal core (4) for about 10 seconds; after release, pilot should remain lit.
 - If the pilot will not stay lit after several tries, turn the gas control knob (3) to OFF (U) and call your local service technician or gas supplier.
 - Reinstall the window and set the MAN-knob (2) to ON; turn Flame Adjustment knob (3) up (U) or down (U) manually or use the flame buttons (🔥) buttons on the remote control handset to adjust the flame height.

TO TURN OFF GAS TO APPLIANCE

1. **AUTOMATIC SHUT-OFF** (using the remote control handset):
- Press and hold the small flame button (🔥) on the remote control handset to shut-off the main burner gas flow.
 - Press OFF button on remote handset to shut-off the appliance, including pilot flame.
2. **MANUAL SHUT-OFF** (using only the ON/OFF switch (1) located to the right hand side of the valve):
- Press **O** the ON/OFF switch (1) to shut-off the appliance, including pilot flame.

Wiring Diagram

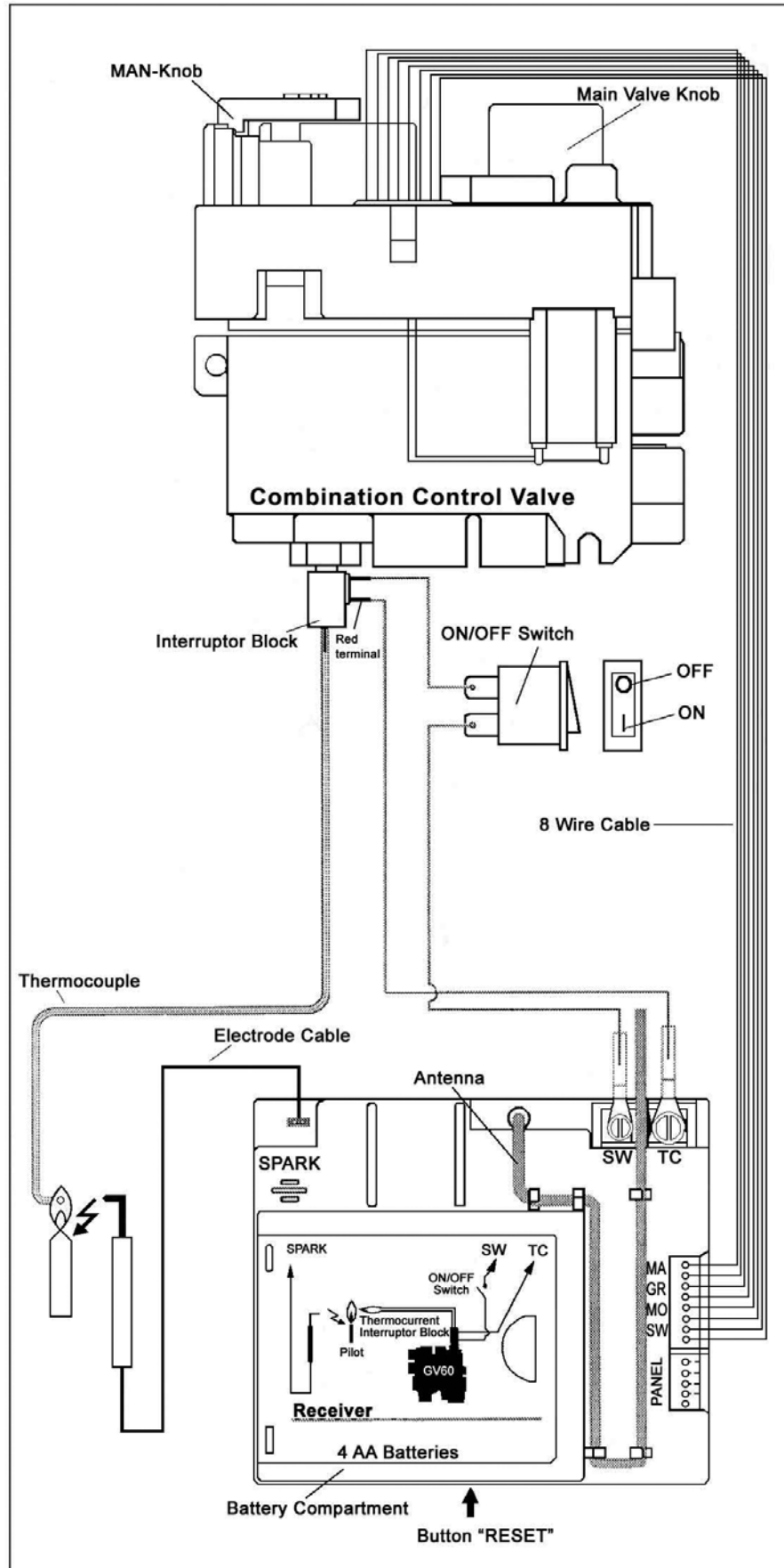

GV60 Wiring Diagram

Options

Fuel **MF28EN**—Natural Gas Installations
MF28EP—Propane Gas Installations

Cast Stoves **MFCS01**—Madrona Stove Kit Standard Black
MFCS02—Madrona Stove Kit Majolica Brown

Safety Screen **MFDKSG**—Madrona Stove Door Kit Safety Guard

Venting **551DVK**—Direct Vent Kit, for horizontal terminations *with vertical rise*.
See also venting accessories listed on pages 34–35.

Fan (Blower) **555CFK**—Circulating Fan Kit with 6' c/w grounded cordset.

Conversion Kits **MA28NK**—Conversion Kit to Natural Gas
MA28PK—Conversion Kit to Propane Gas

Venting accessories



APPROVED ALTERNATIVE DIRECT VENT SUPPLIERS FOR VALOR MODELS 530, 534, 535, AND MF28



Venting Parts Description		Venting Parts Code / availability by Manufacturer						
		SIMPSON DURA-VENT	SELKIRK		SECURE VENT	RLH INDUSTRIES	MILES INDUSTRIES	
Termination Caps	Horizontal	Co-axial Kit, 26" long	—	—	—	—	—	551DVK
		Standard Co-axial	46DVA-HC	4DT-HC	—	—	—	—
		High Wind Co-axial	—	—	—	SV4CHC	—	—
	Vertical	Standard Co-axial	46DVA-VC	4DT-VC	—	—	HSDV4658-1313	—
		High Wind Co-axial	46DVA-VCH	—	—	SV4CGV	—	—
		Extended Co-axial	46DVA-VCE	—	—	—	—	—
		Co-linear	—	—	—	3PDVCV	HS-C33U-99 HS-C33F-1313	559CLT
		Snorkel, 14" Rise	46DVA-SNK14	4DT-ST14	—	—	—	—
	Snorkel, 36" Rise	46DVA-SNK36	4DT-ST36	—	—	—	—	
Vent Adapters / Couplers		Universal Adapter 3" Flex Coupler	2150	—	—	—	—	—
		Co-linear Flex Connector	46DVA-ADF	—	—	—	—	—
		Co-axial-to-Co-linear Adapter	46DVA-GCL	—	—	—	—	556CLA
		Co-linear-to-Co-axial Adapter	46DVA-GK	—	—	—	—	—
Aluminum Flexible Liner		3" diameter	2280 Series	3" ACFL	NOTE: 2-ply liner approved to CAN/ULC S635 suitable for venting gas appliances. As manufactured by Z-Flex.			
Adjustable Pipe Length 4" x 6-5/8"	4" to 10"	Galvanized	—	4DT-ADJ	—	—	—	—
		Black		4DT-ADJ(B)				
	1-1/2" to 6"	Galvanized	—	—	—	SV4LA	—	—
		Black				SV4LBA		
	1-1/2" to 12"	Galvanized	—	—	—	SV4LA12	—	—
		Black				SV4LBA12		
	1-1/2" 24"	Galvanized	—	—	—	SV4LA24	—	—
		Black				SV4LBA24		

Venting accessories

Venting Parts Description		Venting Parts Code / availability by Manufacturer						
		SIMPSON DURA-VENT	SELKIRK		SECURE VENT	RLH INDUSTRIES	MILES INDUSTRIES	
DV 45° Elbows	Galvanized	46DVA-E45	—	—	—	—	—	
	Black	46DVA-E45B	—	—	SV4EBR45	—	—	
	Galvanized Swivel	—	4DT-EL45	—	SV4E45	—	—	
	Black Swivel	—	4DT-EL45(B)	—	SV4EB45	—	—	
DV 90° Elbows	Galvanized	46DVA-E90	—	—	—	—	—	
	Black	46DAV-E90B	—	—	SV4EBR90	—	—	
	Galvanized Swivel	—	4DT-EL90	—	SV4E90	—	—	
	Black Swivel	—	4DT-EL90(B)	—	SV4EB90	—	—	
Pipes 4" x 6 5/8" (ID x OD)	6" long	Galvanized	46DVA-06	4DT-06	—	SV4L6	—	—
		Black	46DVA-06B	4DT-06(B)	—	SV4LB6	—	—
	9" long	Galvanized	46DVA-09	4DT-09	—	—	—	—
		Black	46DVA-09B	4DT-09(B)	—	—	—	—
	12" long	Galvanized	46DVA-12	4DT-12	—	SV4L12	—	—
		Black	46DVA-12B	4DT-12(B)	—	SV4LB12	—	—
	18" long	Galvanized	46DVA-18	4DT-18	—	—	—	—
		Black	46DVA-18B	4DT-18(B)	—	—	—	—
	24" long	Galvanized	46DVA-24	4DT-24	—	SV4L24	—	—
		Black	46DVA-24B	4DT-24(B)	—	SV4LB24	—	—
	36" long	Galvanized	46DVA-36	4DT-36	—	SV4L36	—	—
		Black	46DVA-36B	4DT-36(B)	—	SV4LB36	—	—
	48" long	Galvanized	46DVA-48	4DT-48	—	SV4L48	—	—
		Black	46DVA-48B	4DT-48(B)	—	SV4LB48	—	—
	Flashings	Roof Flashing 0/12-6/12	46DVA-F6	4DT-AF6	—	SV4FA	—	—
		Roof Flashing 7/12-12/12	46DVA-F12	4DT-AF12	—	SV4B	—	—
Flat Roof Flashing		46DVA-FF	—	—	SV4F	—	—	
Various Venting System Parts	Wall Thimble	46DVA-WT	4DT-WT	—	SV4RSM	—	—	
	Storm Collar	46DVA-SC	4DT-SC	—	SV4AC	—	—	
	Decorative Plate	46DVA-DC	4DT-CS	—	SV4PF	—	—	
	Cathedral Ceiling Support	46DVA-CS	4DT-CCS	—	—	—	—	
	Ceiling Firestop / Floor Support	46DVA-FS	4DT-FS	—	SV4BF	—	—	
					SV4SD			
	Wall Strap	46DVA-WS	4DTWS	—	—	—	—	
	Vinyl Siding Standoff	46DVA-VSS	4DT-VS	—	SV4VS	—	—	
	Elbow Strap	46DVA-ES	4DT-OS	—	—	—	—	
Terminal Guard	46DVA-WG	—	—	—	—	835TG		

Notes: 1) Simpson Dura-Vent co-axial pipes and fittings require Valor 817VAK Starter Adapter to fit Valor's smooth collars. All other above manufacturers' collars will fit directly to Simpson Dura-Vent or Valor's smooth collars. 2) Follow instructions supplied with each manufacturer's components. 3) Unless otherwise specified, all the parts and assemblies from the above table are to be used with 4" x 6-5/8" pipes. 4) Termination caps manufactured by RLH Industries are from *Homestyle Chimney Collection* and can be ordered in one of the following finishes: a) aluminium; b) black powder coated; c) solid copper.

Warranty

If you have a problem with this unit, please contact your dealer or supplier immediately. Under no circumstances should you attempt to service the unit in any way by yourself. The warranties in paragraphs 1 and 2 are provided only to the first purchaser/user of this unit, are not transferable and are subject to the conditions and limitations in paragraphs 3, 4 and 5. Please review the conditions and limitations carefully and strictly follow their requirements.



1. Extended Warranty Coverage

For a period of up to ten (10) years, Miles Industries Ltd., (the "Company") or its appointed distributor will at its option pay the initial purchaser for the repair of, or will exchange the following parts or components which are found to be defective in material or workmanship under normal conditions of use and service:

Part or Component	Defect Covered	Maximum Warranty Period
Exterior steel casing	Corrosion	10 years
Glass	Loss of structural integrity	10 years
Cast iron parts	Corrosion	10 years
Firebox and heat exchanger	Corrosion (but not discoloration) causing loss of structural integrity	10 years

2. Two-Year Parts Warranty

In addition, for two (2) years from the date of purchase, the Company, at its option, can repair or exchange all parts and components not listed above but that are found to have a *bona fide* defect in material or workmanship under normal conditions of use.

3. Conditions and Limitations

- a) The warranty registration card must be completed by the initial owner and returned to the Company within 90 days of purchase.
- b) Installation and maintenance must be performed by an authorized and trained dealer in accordance with the Company's installation instructions.
- c) This warranty is void where installation of the unit does not conform to all applicable codes including national and local gas appliance installation codes and building and fire codes.
- d) The owner must comply with all operating instructions.
- e) The Company is not responsible for the labor costs to remove defective parts or re-install repaired or replacement parts.
- f) The first purchaser or user of the unit will be responsible for any shipping charges for replacement parts as well as travel time incurred by the dealer to perform the warranty work.
- g) This warranty applies to non-commercial use and service and is void if it is apparent that there is abuse, misuse, alteration, improper installation, accident or lack of maintenance to the unit.
- h) This warranty does not cover damage to the unit through:
 - i) Improper installation, operational or environmental conditions.
 - ii) Inadequate ventilation in the area or competition for air from other household equipment or appliances.
 - iii) Damage due to chemicals, dampness, condensation, or sulphur in the fuel supply lines which exceeds industry standards.
- i) This warranty does not cover glass, log breakage or damage to the unit while in transit.
- j) The Company does not allow anyone to extend, alter or modify this warranty and assumes no responsibility for direct, indirect or consequential damages caused by the unit. State or provincial laws where the first purchaser or user resides may provide specific rights to extend this warranty and, if so, the Company's sole obligation under this warranty is to provide labor and/or materials in accordance with those laws.

4. Discharge of Liability

After two (2) years from the date of purchase, the Company may, at its option, fully discharge all obligations under this warranty by paying to the first purchaser/user the wholesale price of any defective parts.

5. No Other Warranty

All obligations to repair this unit are defined in this warranty. Some states or provinces may specifically mandate additional warranties on the part of manufacturers, but in the absence of such specific legislation, there is no other warranty or obligation expressed or implied.

Replacement Parts

Cast Stove Parts

	Description	Part no.	Part no.		Description	Part no.	Part no.
		Black	Majolica			Black	Majolica
1	Base	4000926AH	4000926MJ	6	Fret	4000935AH	4000935MJ
2	Top Panel	4000928AH	4000928MJ	7	LH Side Panel	4000931AH	4000931MJ
3	Leg (4)	4000929AH	4000929MJ	8	Infill Plate	4000927AH	4000927MJ
4	RH Side Panel	4000930AH	4000930MJ	9	Hook (2)		4000990
5	Front	4000934AH	4000934MJ		Hardware pack		4000883

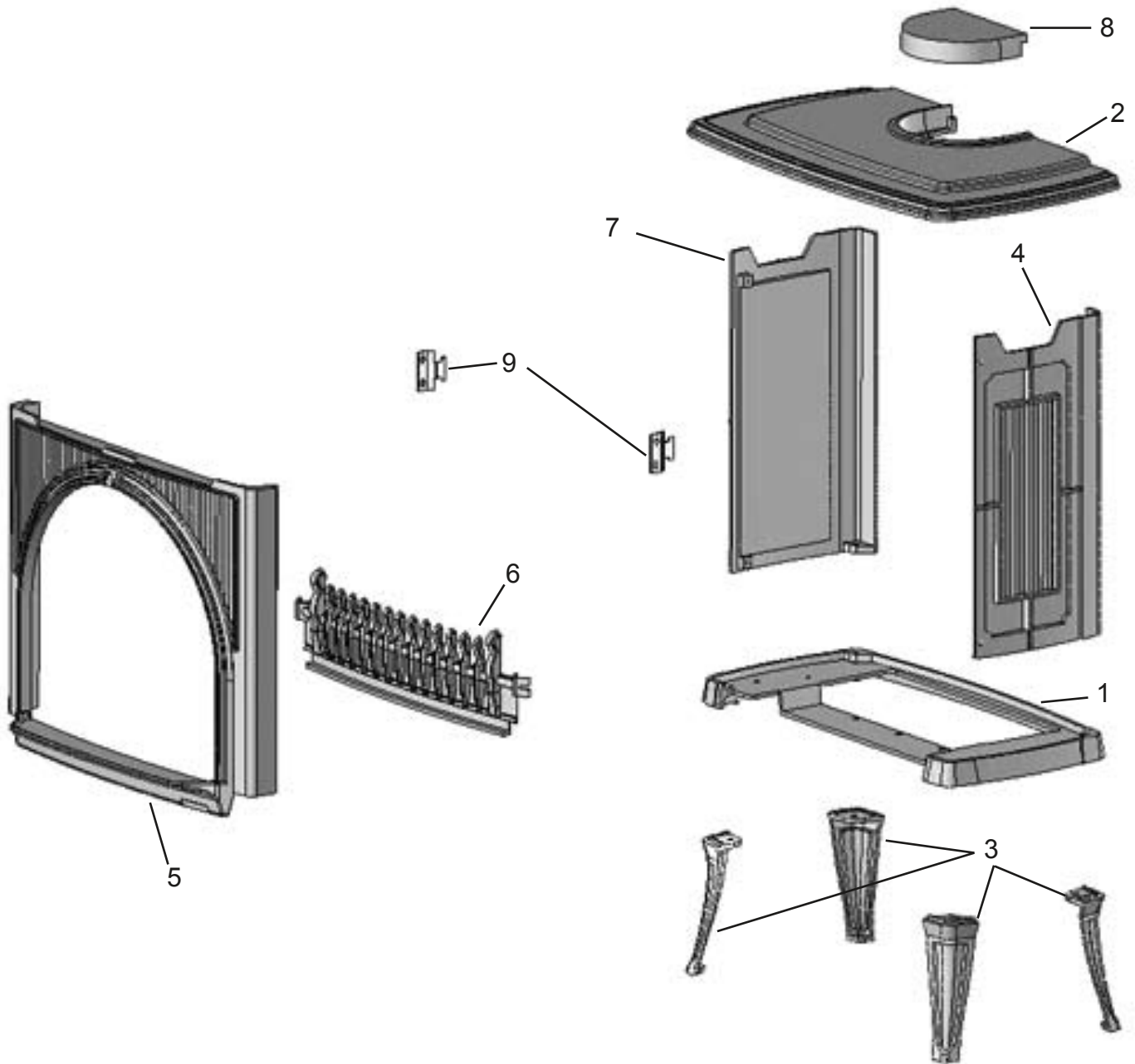

Replacement Parts

Engine Parts

Code	Description	Part no.	Code	Description	Part no.
1	Log Set	4000603	30d	Cable Interruptor/Receiver	4001035
2a	Rear Log	4000688	30e	Servo Motor	4001190
2b	Rear Log LPG	4000688P	31	Front Log Brackets (2)	4000739
3	L/H Cross Log	4000690	32	Shutter Slider	4000759
4	Middle Cross Log	4000689	33	Burner Assembly	4000599
5	R/H Cross Log	4000691	34	Aeration Shutter	4000657
6	Front Log	4000692	35a	Injector Elbow NG	4000738
7	Restrictor 50 (2)	4000949	35b	Injector Elbow LPG	9730035
8	Restrictor 75 (2)	4000950	36	Burner Support Plate	4000579
9	Dura-Vent Intake Collar	4000925	37	Valve Tray	4000636
10	Intake Collar Gasket	4000942	38	Rear Gasket	4000642
11	Exhaust Collar Assembly	4000943	39	R/H Side Gasket	4000644
12	Exhaust Collar Gasket	4000938	40	Front Gasket	4000641
13	Intake Plate	4000908	41	L/H Side Gasket	4000643
14	Intake Plate Gasket	4000941	42	Olive 8mm	420K342
15	R/H Stove Back Corner	4000922	43	Olive Nut	220K567
16	L/H Stove Back Corner	4000923	44	Pipe Valve to Main Burner	4000600
17	Firebox Assembly	4000920	45	Tube Nut	220K558
18a	Rear Log Support	4000621	46	Valve Mount	4000141
18b	Rear Log Support LPG	4001456	47a	Pilot Assembly NG	4000727
19a	Burner Tray Assy NG	4000894	47b	Pilot Assembly LPG	4000728
19b	Burner Tray Assy LPG	4000895	48	Electrode	720A543
20	Window Assembly	4000919	49	Pilot Tube	4000732
21	Heat Reduction Baffle	4000974	50	Extended Nut	720A200
22	Fan Control Bracket	9000946	51	Pilot Gasket	4000715
23	Inlet Pipe	030A224	52	Pilot Bracket	4000729
24a	Inlet Connector	220K997	53	Thermocouple	4000061
24b	Pipe to Valve Connector	220K891	54a	Pilot Injector #62 NG	4001352
25	Top Spar	4000916	54b	Pilot Injector #30 LPG	4000736
27	GV60 Valve	4000873	55	Two-Flame Pilot Hood	4000730
28	Receiver	4001911	56	Switch Bracket	4001070
29	Wiring Harness	4001187	57	Receiver Clip	4001164
30	Remote Control Handset	4001910	not shown	Pilot Tube Connector	4001034
30a	Switch with Cable	4001036	58	Handset Wall Holder	9000008
30b	Interruptor Block	4001037	59	Front Log Support LPG	4001457
30c	Ignition Cable	4001039	60	Remote Control Thermostatic	4001857

Replacement Parts

