

INSTALLATION & OWNER'S MANUAL



LX2 Series



Direct Vent Zero Clearance Corner Gas Fireplaces 2200LJN/RJN (natural gas) / 2200LJP/RJP (propane gas)

DANGER

Please read this manual
BEFORE installing and
operating this appliance.



**HOT GLASS WILL
CAUSE BURNS.**

**DO NOT TOUCH GLASS
UNTIL COOLED.**

**NEVER ALLOW CHILDREN
TO TOUCH GLASS.**

A barrier designed to reduce the risk of burns from the hot viewing glass is provided with this appliance and shall be installed for the protection of children and other at-risk individuals.

INSTALLER

Leave this manual
with the appliance.

CONSUMER

Retain this manual
for future reference.

WARNING

FIRE OR EXPLOSION HAZARD

Failure to follow safety warnings exactly could result in serious injury, death, or property damage.

- Do not store or use gasoline or other flammable vapors and liquids in the vicinity of this or any other appliance.
- **WHAT TO DO IF YOU SMELL GAS**
 - Do not try to light any appliance.
 - Do not touch any electrical switch; do not use any phone in your building.
 - Leave the building immediately.
 - Immediately call your gas supplier from a neighbor's phone. Follow the gas supplier's instructions.
 - If you cannot reach your gas supplier, call the fire department.
- Installation and service must be performed by a qualified installer, service agency or the gas supplier.

This appliance may be installed in an after-market permanently located, manufactured (mobile) home where not prohibited by local codes.

This appliance is only for use with the type of gas indicated on the rating plate. This appliance is not convertible for use with other gases, unless a certified kit is used.

This appliance is a domestic room-heating appliance. It must not be used for any other purposes such as drying clothes, etc.

This appliance is suitable for installation in a bedroom or bed sitting room.

Ce guide est disponible en français sur demande.

TABLE OF CONTENTS

FOR THE OWNER

Safety and Your Fireplace	3
Introduction	6
Information About Your Fireplace	6
First Operation.....	7
Operating Your Fireplace	8
Fireplace Control Devices	8
How to Turn Your Fireplace OFF (including pilot).....	8
How to Ensure Your Fireplace Cannot Be Turned ON Inadvertently	8
Using the Remote Control	9
Using the Wall Switch	15
Kits & Accessories	15
Lighting Instructions	16
Maintaining Your Fireplace	17
Servicing Your Fireplace.....	17
Annual Inspection.....	17
Cleaning Your Fireplace	18
Checking Pilot and Burner Flames	21
Replacing Batteries	22
Using Remote Control Handset Wall Holder	22
Replacing Light Bulbs.....	23
Warranty	72

Warranty Card at the back of this manual.



The information contained in this installation manual is believed to be correct at the time of printing. Miles Industries Ltd. reserves the right to change or modify any information or specifications without notice. Miles Industries Ltd. grants no warranty, implied or stated, for the installation or maintenance of your heater, and assumes no responsibility for any consequential damage(s).



We recommend that our gas hearth products be installed and serviced by professionals who are certified in the U.S. by the National Fireplace Institute® (NFI) as NFI Gas Specialists.

Designed and Manufactured by / for Miles Industries Ltd.
190–2255 Dollarton Highway,
North Vancouver, BC, CANADA V7H 3B1
Tel. 604-984-3496 Fax 604-984-0246
www.valorfireplaces.com

FOR THE QUALIFIED INSTALLER

Specifications	24
Overview	25
Dimensions & Location	26
Clearances to Combustible Projections	27
Venting	33
Installation Planning	39
Plan Wall Finish.....	40
Installation	41
Unpack Appliance.....	41
Remove Base Plate and Window	41
Install Standoffs	42
Install 6-5/8" x 4" Vent Adapter (if required).....	42
Install HeatShift Take-off Collars (required).....	42
Prepare Appliance for Wiring.....	42
Set-up Gas Supply	44
Place Appliance in Final Position.....	45
Complete Installation of HeatShift Kit (required)	45
Install Liners	46
Install Long Beach Driftwood 1705DWK	48
Install Decorative Glass Murano 2200DGM	51
Install Decorative Glass Set 2200DGS.....	52
Install Splitwood Kit 1700SWK	53
Install Rocks & Shale 1714RSS	58
Install Remote Battery and Wall Switch Kit RBWSK (required).....	62
Initialize Remote Control	64
Check Operation.....	65
Set Aeration (if necessary)	65
Reinstall Base Plate	66
Install Barrier Screen	66
Install Remote Control Handset Wall Holder	66
Wiring Diagram	67
Approved Venting Components	68
Commonwealth of Massachusetts	70
Warranty	72
Spare Parts	73

Massachusetts: The piping and final gas connection must be performed by a licensed plumber or gas fitter in the State of Massachusetts. Also, see Carbon Monoxide Detector requirements on page 70.



SAFETY AND YOUR FIREPLACE

Read and understand all instructions carefully before starting the installation. **Failure to follow** these installation instructions may result in possible fire hazard and will void the warranty.

Prior to the first firing of the fireplace, read the Owner's information section of this manual.

Do not use this appliance if any part has been under water. Immediately, call a qualified service technician to inspect the unit and to replace any part of the control system and any gas control that has been under water.

This unit is not for use with solid fuel.

Installation and repair should be performed by a qualified service person. The appliance and venting system should be **inspected** before initial use and at least annually by a professional service person. More frequent cleaning may be required due to excessive lint from carpeting, bedding, etc. It is **imperative** that the unit's control compartment, burner, and circulating air passageways **be kept clean** to provide for adequate combustion and ventilation air.

Always keep the appliance clear and free from combustible materials, gasoline, and other flammable vapors and liquids.

Never obstruct the flow of combustion and ventilation air. Keep the front of the appliance **clear** of all obstacles and materials for servicing and proper operation.

This unit must be used with a vent system as described in this installation manual. **No other vent system or components may be used.**

This gas fireplace and vent assembly must be vented directly to the outside and must never be attached to a chimney serving a separate solid fuel burning appliance. Each gas appliance must use a separate vent system. Common vent systems are prohibited.

Inspect the external vent cap on a regular basis to make sure that no debris, plants, trees, shrubs are interfering with the air flow.

Turn off the gas before servicing this appliance. It is recommended that a qualified service technician perform an appliance check-up at the beginning of each heating season.



WARNING:

This product can potentially expose you to chemicals including Benzene which are known to the State of California to cause cancer and birth defects or other reproductive harm. **For more information go to www.P65Warnings.ca.gov**

Do not use this heater as a temporary source of heat during construction.

Due to the high temperature, the appliance should be **located** out of traffic areas and away from furniture and draperies.

Clothing or flammable material **should not be placed** on or near the appliance.

This appliance is a **domestic room-heating appliance**. It must not be used for any other purposes such as drying clothes, etc.

Do not place furniture or any other combustible household objects within 36" of the fireplace front.

Be careful not to put any decorating objects sensitive to heat to close above or around the fireplace as it gets very hot when operating.

The glass door assembly must be in place and sealed before the unit can be placed into safe operation.

Do not operate this appliance with the glass door removed, cracked, or broken. Replacement of the glass door should be performed by a licensed or qualified service person. Do not strike or slam the glass door.

The glass door assembly shall only be replaced as a complete unit, as supplied by the fireplace manufacturer. No substitute material may be used.

Do not use abrasive cleaners on the glass door assembly. Do not attempt to clean the glass door when it is hot.

A barrier designed to reduce the risk of burns from the hot viewing glass is provided with this appliance and **shall be installed for the protection of children and other at-risk individuals.**

If the barrier becomes damaged, the barrier shall be replaced with the manufacturer's barrier for this appliance.

Any safety screen, guard or barrier removed for servicing the appliance, must be replaced prior to operating the appliance.

Children and adults should be alerted to the hazards of high surface temperature and should stay away to avoid burns or clothing ignition.

Young children should be carefully supervised when they are in the same room as the appliance. Toddlers, young children and others may be susceptible to accidental contact burns. A physical barrier is recommended if there are at-risk individuals in the house. To restrict access to a fireplace or stove, install an adjustable safety gate to keep toddlers, young children and other at-risk individuals out of the room and away from hot surfaces.



Safety and Your Fireplace

Read and carefully follow all safety warnings and operating instructions contained in your owner's manual

Replacement manuals are available by contacting the Valor Service Department at 1-800-468-2567 or visit www.valorfireplaces.com.

FOLLOW THESE IMPORTANT CHILD SAFETY PRECAUTIONS AND RECOMMENDATIONS

Parts of your Valor Fireplace become extremely hot while in operation.

The glass viewing window temperature can exceed 500 F at full capacity.

Momentary contact with a hot glass surface can cause a severe burn, even if the fireplace is operating at reduced heating capacity.

The glass window will remain hot for an extended period of time after the fireplace has been turned off. Ensure that children are prevented from touching the fireplace during the cool down period.

Toddlers and Young Children must be closely supervised at all times when they are in the same room as the operating fireplace. They lack full awareness of danger and rely on your protection. Toddlers, in particular, do not have the motor skills and response reflexes to withdraw in the event of accidental contact with a hot surface.

A physical barrier is strongly recommended if there are young children, or at-risk individuals in the house. Install an approved after-market safety gate to keep toddlers, young children and



other at-risk individuals a safe distance from the fireplace.

Keep the remote control handset out of reach of children at all times. A wall mount storage holster is provided with your remote control handset.

Ensure that the fireplace, including the pilot light, is completely turned off when children are present and close supervision and safety barriers are not available—see page 8 of this manual.

If the fireplace is not going to be used for the summer or any extended period of time, remove the batteries from the remote control handset and remote battery box. It is recommended that batteries are replaced annually in any event—see page 22.



SAFETY AND YOUR FIREPLACE

This manual and particularly the preceding and following pages contain very important information regarding the safe operation of your fireplace as well as maintenance instructions. Read carefully before operating your fireplace and pay special attention to the safety warnings.

A heating gas appliance does require safe handling. For this reason, we very strongly recommend children are not allowed to touch the fireplace or controls. **Install a screen or barrier in front of the fireplace to protect your children against severe burns.**

This appliance is designed and approved as a supplemental heater and provides the potential for most energy conservation when used while attended. The use of an alternate primary heat source is advisable.



WARNING EXTREMELY HOT!!!

- **Read the safety information on pages 3 and 4 of this manual before operating your gas heater.**
- Some parts of your fireplace are **extremely hot**, particularly the **glass window**.
- **Do not let children touch the glass** or any parts of your fireplace **even after it is turned off** as it is still hot.
- **Use the barrier screen** provided with the trim or a gate to reduce the risk of severe burns.
- Keep the remote control handset **out of reach of children**.
- **Hot wall surfaces!** The wall directly above the fireplace is **very hot** when the fireplace heats. It is constructed of non-combustible materials and although safe, it may reach temperatures **in excess of 200° F. Do not touch!**
- **Hot hearth/floor surface!** The hearth or floor directly in front of the fireplace is very hot when the fireplace heats. Even if constructed of non-combustible materials, and although safe, it may reach temperatures **in excess of 200° F** depending on choice of materials. **Do not step on it!**
- Some materials or items, although safe, may discolor, shrink, warp, crack, peel, and so on because of the heat produced by the fireplace. **Avoid placing** candles, paintings, photos, and other items **sensitive to heat** within 36 inches (0.9 M) around the fireplace.
- Solid wood flooring in front of the fireplace (if allowed) may shrink during the heating season due to heat.

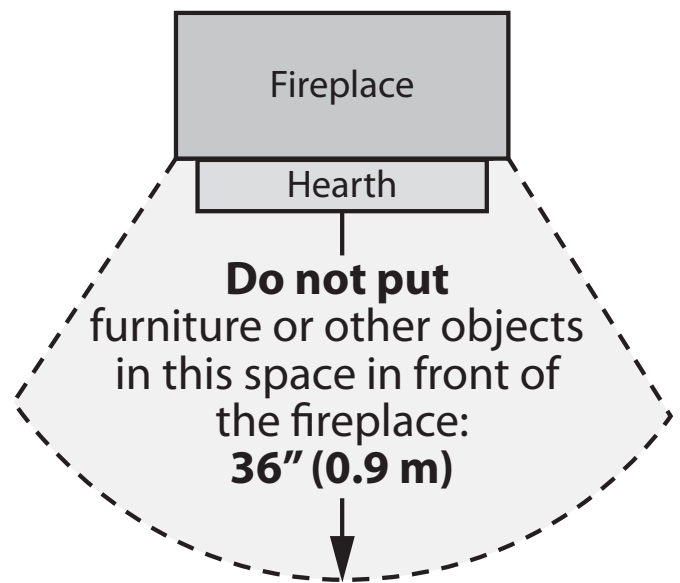

WARNING

HeatShift Duct Kit:
Do not cover or place items in front of or above outlet(s)!

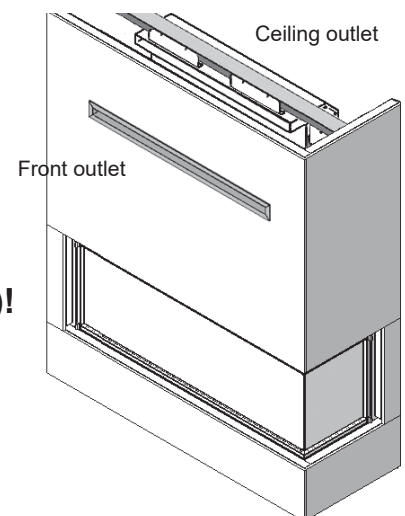

INTRODUCTION

Thank You ...

For purchasing a Valor by Miles Industries. Your new radiant gas heater is a technical appliance that must be installed by a qualified dealer. Each Valor fireplace is fully tested during the production process for your safety and comfort.

Your unit has been professionally installed by:

Dealer Name: _____

Phone Number : _____

Should you encounter an operational problem, call your dealer immediately.

Do not try to repair the unit as you may cause an injury or damage the fireplace.

Information About Your Fireplace

⚠ WARNING

DO NOT ATTEMPT TO TOUCH THE DATA CARD WHILE THE FIREPLACE IS STILL HOT! Let the fireplace cool first before touching it.

The Fireplace and Lighting Information card is located behind the front panel of the appliance, below the window. To access the card, the barrier screen and the base plate on which it sits must be removed.

1. The screens are held to the fireplace by magnets.

Remove the screens:

- a) pull out the top of the front screen;
- b) lift out the front screen;
- c) pull out the top of the side screen;
- d) lift out the side screen.

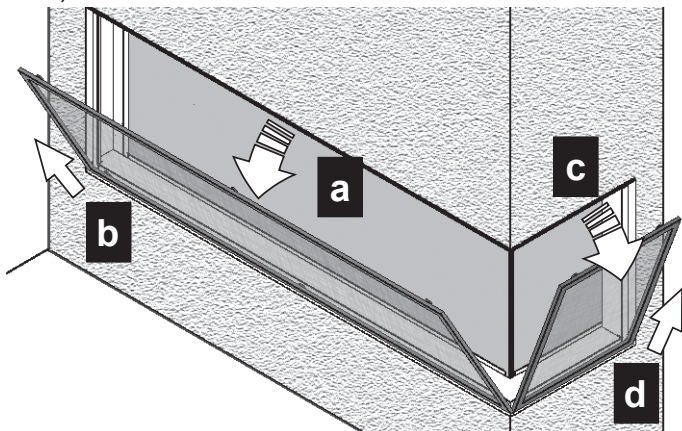

2. From the open corner,
 - a) slide the base plate sideways;
 - b) lift the plate up.

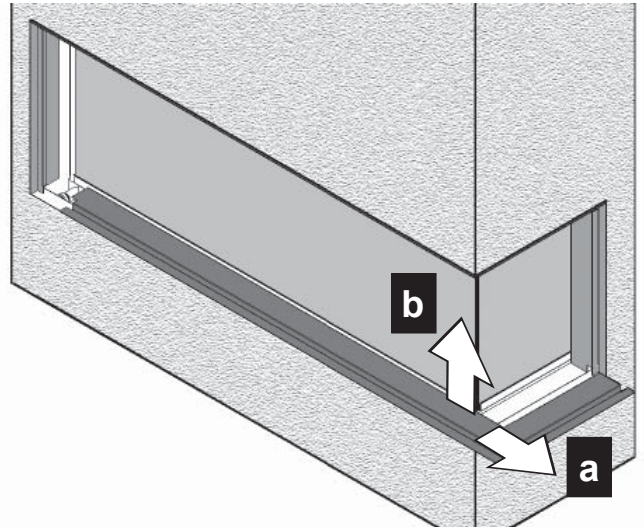

3. The card is located at the right hand side below the window. Grab the card and pull it out. There is important information on both sides of the card.

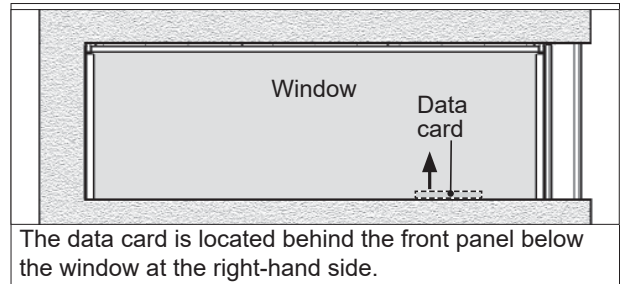

The data card is located behind the front panel below the window at the right-hand side.

Fireplace model
Serial number

MILES INDUSTRIES LTD. NORTH VANCOUVER, B.C. CANADA		NET HEAT (MAX) 24,000 Btu/hr
MODEL/MODELE 739MN		HEAT LOSS COEFFICIENT (Min) 6,500 Btu/hr
F-FIRE NATURAL GAS / POSEUR LE GAZ NATUREL		MINIMUM FREESTANDING CLEARANCE TO WALLS (Min) 3.2"
SERIAL NO. (N° DE SÉRIE) 739N 10000		MINIMUM FREESTANDING CLEARANCE TO WALLS (Max) 5.0"
APPROXIMATE WEIGHT (POIDS APPROXIMATIF) Net Weight (Poids Net) 75 lbs (34 kg) Gross Weight (Poids Brut) 85 lbs (38 kg)		APPROXIMATE HEIGHT (POIDS APPROXIMATIF) Net Height (Poids Net) 750 mm Gross Height (Poids Brut) 850 mm
MILES INDUSTRIES LTD. (MILES INDUSTRIES) 12000 160th Street, North Vancouver, BC V4N 1C5, Canada Tel: (604) 295-7422 Fax: (604) 295-7425		VALOR RADIANT GAS HEATERS
MILES INDUSTRIES LTD. (MILES INDUSTRIES) 12000 160th Street, North Vancouver, BC V4N 1C5, Canada Tel: (604) 295-7422 Fax: (604) 295-7425		VALOR RADIANT GAS HEATERS

4. Reinstall the base plate:
- place the base plate on the fireplace's front flange with the **magnets behind the fireplace's front panel**;

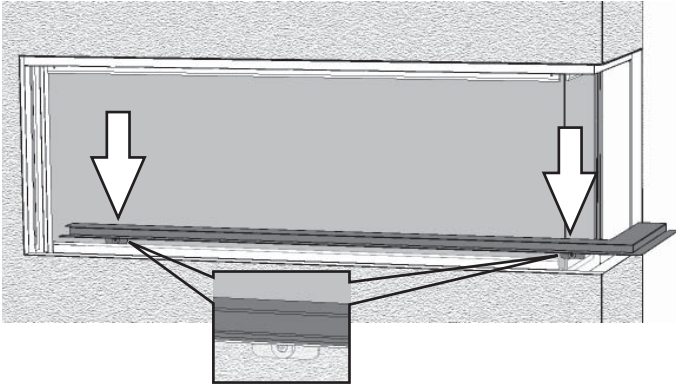

- ensuring the plate is lined up with the flange, slide the plate sideways so both its ends butt with the vertical panels of the black frame;

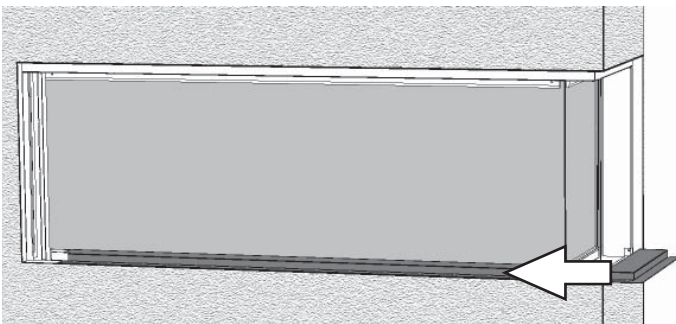

- pull the plate forward so it is flush with the fireplace's front flange.

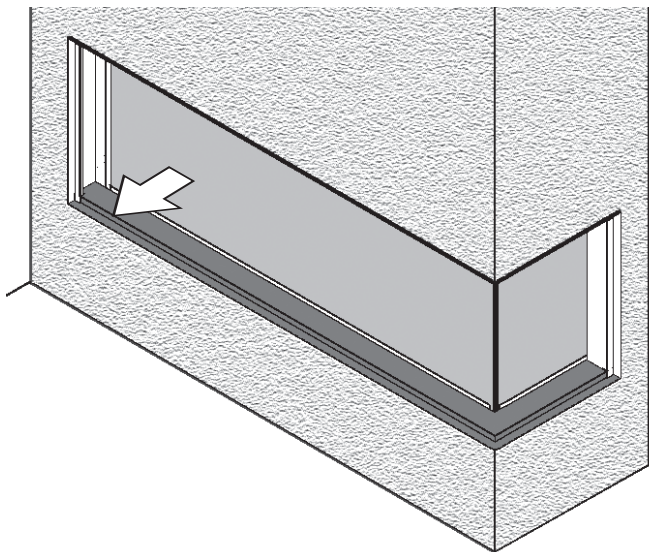

5. Reinstall the barrier screen:
- place the side screen, magnets inboard, against the ridge of the base plate;
 - push the top of the screen against the ridge of the top plate.
 - place the front screen, magnets inboard, against the ridge of the base plate;
 - push the top of the screen against the ridge of the top plate.

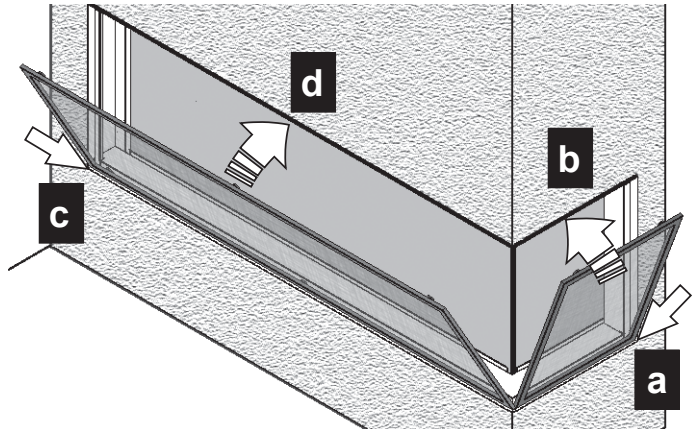

First Operation

When operating your new fireplace for the first time, some vapors may be released due to the burning of curing compounds used in the manufacture of the appliance. They may cause a slight odor and could cause the flames to be the full height of the firebox, or even slightly higher, for the first few hours of operation.

It is also possible that these vapors could set off any smoke detection alarms in the immediate vicinity. These vapors are quite normal on new appliances. We recommend opening a window to vent the room. After a few hours use, the vapors will have disappeared and the flames will be at their normal height.

Flame Supervision Device

For your safety, this appliance is fitted with a flame supervision device which will shut-off the gas supply if, for any reason, the pilot flame goes out. This device incorporates a fixed probe, which senses the heat from the pilot flame. If the probe is cool, the device will prevent any gas flow unless manually lighting the pilot. See full lighting instructions on page 16 of this manual.

Performance of propane gas appliances may be affected by the quality of commercial gas supplied in your area.

OPERATING YOUR FIREPLACE

Fireplace Control Devices

There are two ways to control your fireplace.

1. Thermostatic Remote Control;
2. Wall Switch.

The Thermostatic Remote Control can be programmed to function automatically—see pages 9–14.

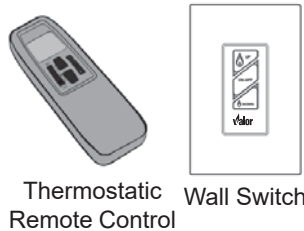

The Wall Switch can be used to turn on, off and to increase or decrease the flame height—see page 15.

How to Turn Your Fireplace OFF (including pilot)

Familiarize yourself with each of these methods before operating your fireplace.

Press and hold the OFF button for a second (either on the handset or the wall switch).

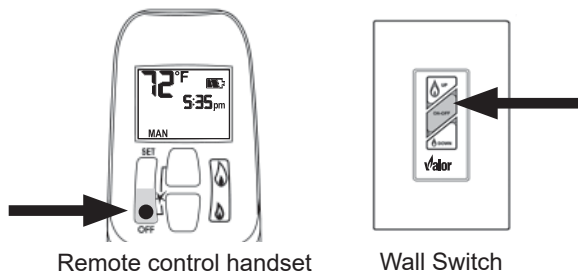

If the flames are on, they go down and you hear the valve motor wind down. You hear a clunk and a beep indicating that the valve has received the signal from the remote control.

In the unlikely event that you cannot turn off your fireplace with the remote control handset, use the wall switch (if installed); if the wall switch malfunctions and will not turn off the fireplace, wait 6 hours and the fireplace will automatically go to pilot. You can then access the controls inside your fireplace. Alternately, turn off gas supply. In all cases, call your dealer for service assistance.

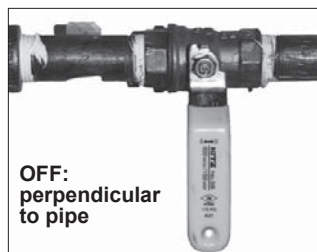

How to Ensure Your Fireplace Cannot Be Turned ON Inadvertently

First, ensure your fireplace is turned off—including the pilot—and cold **BEFORE** going ahead.

⚠ WARNING

RISKS OF SEVERE BURNS! SURFACES OF THE FIREPLACE ARE VERY HOT DURING OPERATION! Be very careful and wear gloves to access controls.

Turn off gas supply to the fireplace. Access the gas shut-off valve by removing the barrier screens and the bottom black plate. The shut-off valve is located behind the front panel on the left of the gas valve as indicated.

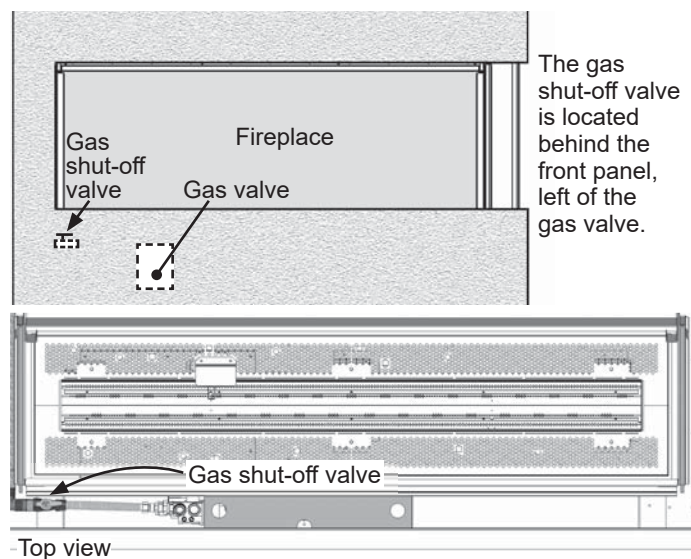

Turn the shut-off valve from the ON position (handle parallel) to the OFF position (handle perpendicular) as shown. This will cut off the gas supply to the fireplace and will ensure that the main burner can not come on.

NOTE: Ensure shut-off valve is turned back to ON position (handle parallel) before operating the fireplace.

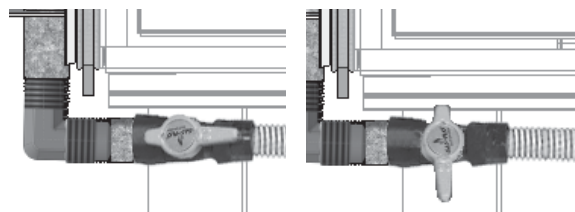

Automatic Shut-Off (in certain conditions)

Your fireplace's remote control is equipped with an automatic shut-off mechanism which is activated in certain conditions. See page 14 in the *Using the Remote Control* section for a description of this feature.

USING THE REMOTE CONTROL

Radio Frequency

315 MHz for USA and Canada.

This device complies with Part 15 of the FCC Rules and with Industry Canada license-exempt RSS standard(s). Operation is subject to the following two conditions:

- (1) this device may not cause harmful interference, and
- (2) this device must accept any interference received, including interference that may cause undesired operation.

NOTE: Before using the remote control system for the first time, the receiver and the handset must be synchronized. See the section *Synchronize Remote Control* in this manual.

IMPORTANT: BEFORE YOU BEGIN, please note that on this system, the settings of time, temperature and automatic ON/OFF **can only be programmed when the function display is flashing**. Be patient when programming as it can take a few seconds to set.

Note: In the TEMP or TIMER modes, the remote handset senses the room temperature and adjusts the flame accordingly.

To communicate, the handset should be within 15 feet (4.5 meters) of the fireplace.

Do not leave the handset on the mantel or hearth.

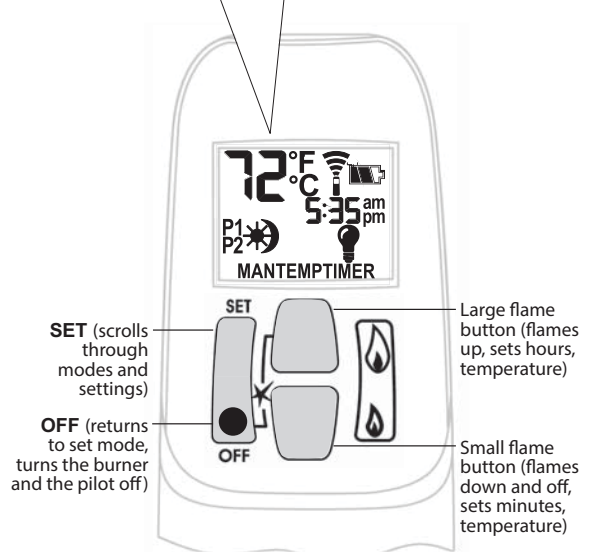
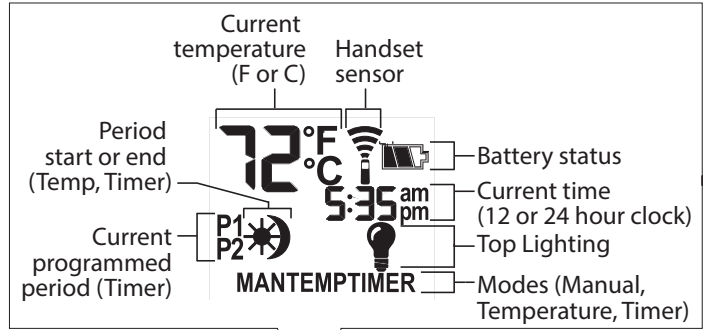

TO TURN ON APPLIANCE

CAUTION

When pilot ignition is confirmed, motor turns automatically to maximum flame height.

On the valve, turn MAN knob on the ON, full counterclockwise  position.

Place ON/OFF switch (if equipped) in I (ON position).

Simultaneously press the OFF and  (large flame) buttons until a short beep confirms the start sequence has begun; release buttons.

Continuing beeps confirm the ignition is in process.

Once pilot ignition is confirmed, there is main gas flow.

After main burner ignition the handset will automatically go into manual (MAN) control mode.

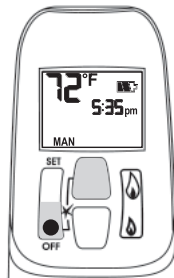

TO TURN OFF APPLIANCE

Press OFF button.

When the pilot is off, it will take 2 minutes before it can be lit again.

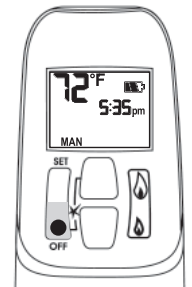

STANDBY MODE (Pilot Flame)

Press and hold  (small flame) to set appliance at pilot flame.

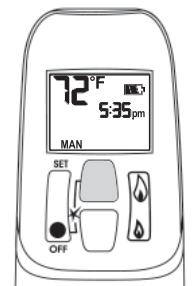

FLAME HEIGHT ADJUSTMENT

In standby mode: Press and hold  (large flame) button to increase flame height.



USING THE REMOTE CONTROL

Press and hold  (small flame) button to decrease flame height or to set the appliance at pilot flame.

For fine adjustment tap the  (large flame) or  (small flame) buttons.

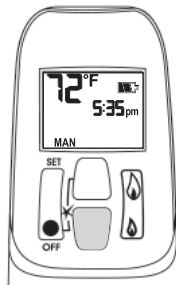

Express Low and High Fire

Double-click  (small flame) button. "LO" will be displayed.

NOTE: Flame goes to high fire first before going to designated low fire.

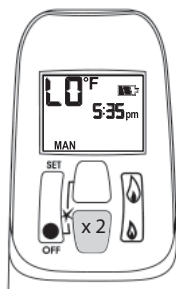

Double-click  (large flame) button. Flame automatically goes to high fire. "HI" will be displayed.

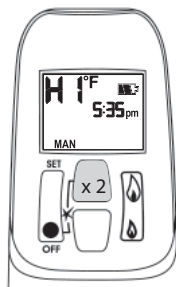

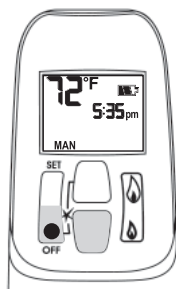

SETTING °C/24-HR OR °F/12-HR CLOCK

In MAN mode, press OFF and  (small flame) buttons until display changes from Fahrenheit/12-hour clock to Celsius/24-hour clock and vice versa.



SETTING THE TIME

The time display will flash after either:

- Installing the battery or
- Simultaneously pressing the  (large flame) and  (small flame) buttons.

Press  (large flame) button to set the hour.

Press  (small flame) button to set the minute.

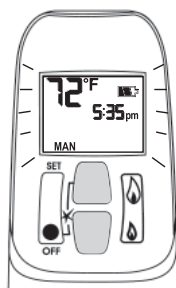

Press OFF or simply wait to return to MAN mode.

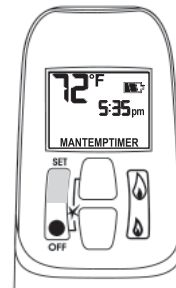
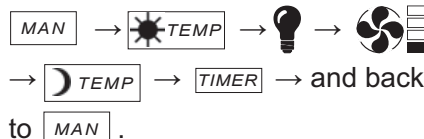

MODES OF OPERATION

Briefly pressing the SET button changes the mode of operation in the following order:



NOTE: Manual mode can also be reached by pressing either the  (large flame) or the  (small flame) buttons.

MAN - Manual Mode - Manual Flame Height Adjustment.

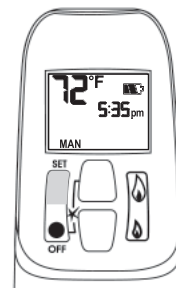

TEMP - Daytime Temperature Mode (Appliance must be in standby mode; pilot ignited) - The room temperature is measured and compared to the set temperature. The flame height is then automatically adjusted to achieve the Daytime Set Temperature.

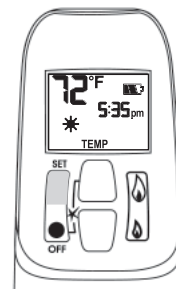

Light - Light/Dimmer Setting Mode Turns light/dimmer ON and OFF and adjust brightness.

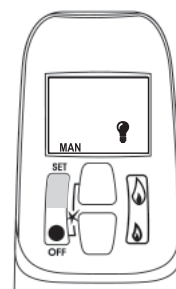

Fan - Fan Mode Not available on this fireplace.

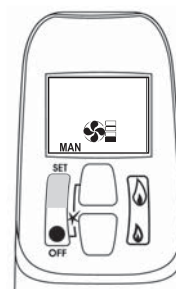

USING THE REMOTE CONTROL

TEMP - Nighttime Setback

Temperature Mode (Appliance must be in standby mode; pilot ignited) - The room temperature is measured and compared to the Nighttime Setback temperature. The flame height is then automatically adjusted to achieve the Nighttime Setback Temperature.

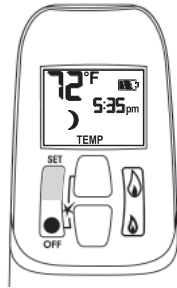

TIMER - Timer Mode (Appliance must be in standby mode; pilot ignited) - The timers P1 and P2 (Program 1, Program 2) each can be programmed to go ON and OFF at specific times. For instructions see Timer Programming Mode.

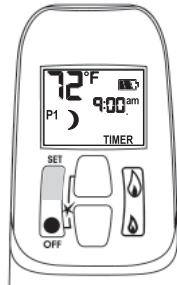

NOTE: The display shows the set temperature every 30 seconds.

LIGHT/DIMMER OPERATION (FIREBOX TOP)

Light/Dimmer

Briefly press SET button to scroll to  (light bulb) mode. Light bulb icon flashes.

Press and hold  (large flame) button to turn ON the light or increase brightness.

Press and hold  (small flame) button to decrease brightness.

In the Light/Dimmer mode, the OFF button shuts off the light.

If you want the light ON but no flame, press and hold the  (small flame) button and turn to Pilot flame.



NOTE: The light bulb icon is displayed during light/dimmer setting only. 8 seconds after the light/dimmer has been set, the handset will automatically go into temperature control mode.

Tip

Set the different parameters when they are flashing.

USING THE REMOTE CONTROL



SETTING THE ON / OFF TEMPERATURES

SETTING THE "DAYTIME" TEMPERATURE

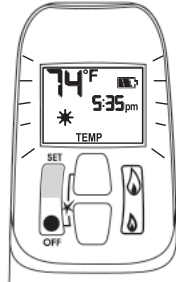

Default Settings:  TEMP (sun), 23°C / 74°F

Briefly press SET button to scroll to TEMP  TEMP (sun) mode. Hold the SET button until the TEMP flashes.

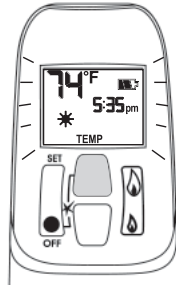

Press  (large flame) button to increase the  Daytime Set Temperature.



Press  (small flame) button to decrease  Daytime Set Temperature.

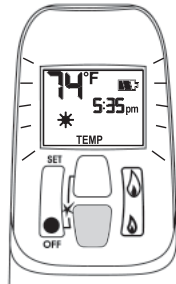

Press OFF or simply wait to complete programming.

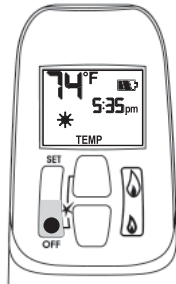



SETTING THE "NIGHTTIME SETBACK" TEMPERATURE

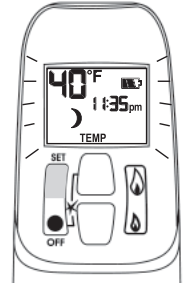

Default Settings:  TEMP (moon), "--" (OFF)

Briefly press SET button to scroll to TEMP  TEMP (moon) mode. Hold the SET button until the TEMP flashes.

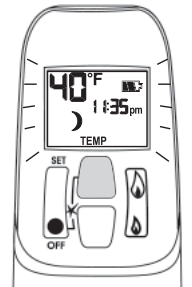

Press  (large flame) button to increase  Nighttime Setback Temperature.



Press  (small flame) button to decrease  Nighttime Setback Temperature.

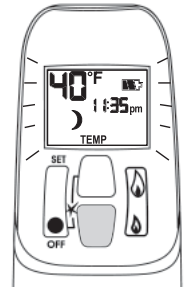

Press OFF or simply wait to complete programming.

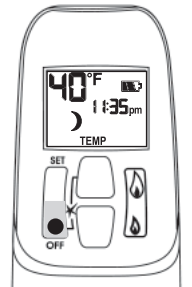

USING THE REMOTE CONTROL

SETTING PROGRAM TIMERS

You can program two periods of time between 12:00 am and 11:50 pm in each 24-hour cycle.

The Programs P1 and P2 must be set in the following order during a 24-hour cycle: **P1** ☀, **P1** 🌙, **P2** ☀ and **P2** 🌙.

The icon ☀ indicates the beginning of the period (ON) and the icon 🌙 indicates the end of the period (OFF).

If **P1** ☀ = **P1** 🌙 or **P2** ☀ = **P2** 🌙, the programming is cancelled.

To keep the fireplace ON all night, set **P2** 🌙 at 11:50 am and **P1** ☀ at 12:00 am.

Default settings:

Program 1: **P1** ☀ 6:00 am **P1** 🌙 8:00 am

Program 2: **P2** ☀ 11:50 pm **P2** 🌙 11:50 pm

Briefly press SET button to scroll to TIMER mode.

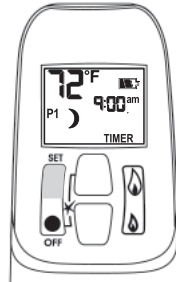

SETTING P1 ON TIME

Hold the SET button until **P1** ☀ (sun) is displayed and the time flashes.

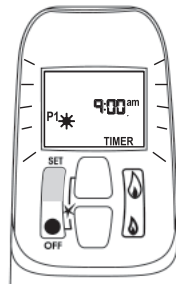

Press 🔥 (large flame) button to set the hour.

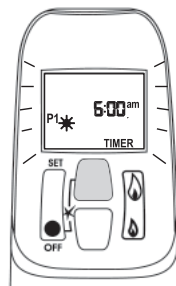

Press 🔥 (small flame) button to set the minutes.

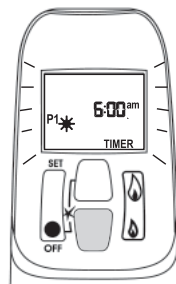

SETTING P1 OFF TIME

Briefly press SET button to scroll to TIMER **P1** 🌙 (moon) while the time flashes.

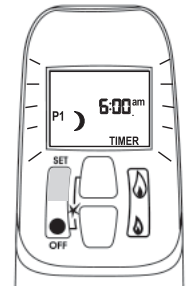

Press 🔥 (large flame) button to set the hour.

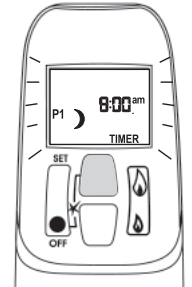

Press 🔥 (small flame) button to set the minutes.

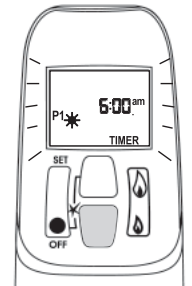

SETTING P2 ON TIME

Briefly press SET to scroll to TIMER mode **P2** ☀ (sun) while the time flashes.

Follow the instructions given to set P1 ON time.

SETTING P2 OFF TIME

Briefly press SET to scroll to TIMER mode **P2** 🌙 (moon) while the time flashes.

Follow the instructions given to set P1 OFF time.

Press OFF button to save these settings. The timers are programmed. See the diagram on programming sequences on the following page.

Tip

If you want to program only one period, program **P1** ☀ and **P1** 🌙 with desired times and program **P2** ☀ and **P2** 🌙 with the same time as **P1** 🌙.

USING THE REMOTE CONTROL

Timer Programming Example (default temperatures shown)

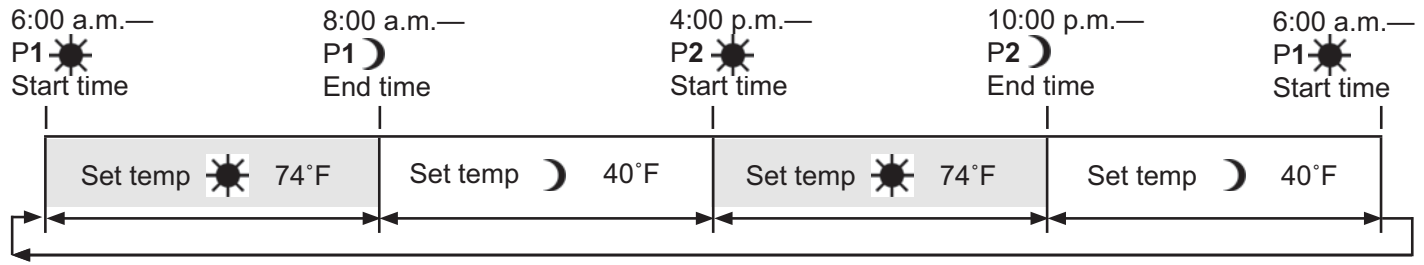

AUTOMATIC TURN DOWN

6 Hour no Motor Movement

Manual Mode/Temperature/Timer Mode: The valve will turn to pilot flame if there is no change in flame height for a 6 hour period. In Temperature/Timer Mode if the ambient room temperature changes, the flame height will adjust automatically to maintain set temperature, and the fire will continue to function normally. The valve will turn to pilot flame if the set temperature and the ambient room temperature remain the same over a 6 hour period.

AUTOMATIC SHUT OFF

Low batteries receiver. With low battery power in the receiver/battery holder the system shuts off the fire completely. This does not apply when the power supply is interrupted.

On-Demand Pilot. This green feature eliminates gas energy consumption during extended appliance inactivity. When the appliance is inactive for 5 days the system automatically extinguishes the pilot. This feature helps the consumer realize cost benefits by automatically eliminating energy consumption during non-heating months and limited use.

LOW BATTERY INDICATION

CAUTION

DO NOT USE a screwdriver or other metallic object to remove the batteries from the battery box or the handset! This could cause a short circuit.

Remote handset: The battery icon  will show when the battery needs to be replaced. Replace with one 9 V **alkaline** battery.

Remote battery holder: Frequent 'beeps' for 3 seconds when the valve motor turns indicate the batteries need to be replaced. Replace with four 1.5 V **alkaline** batteries.

HANDSET / RECEIVER MATCH

The remote control handset and receiver are programmed to function together. In case of a replacement of the handset or the receiver, you will need to reset the receiver to allow them to function together. Contact your dealer for details.

USING THE WALL SWITCH

The Wall Switch can be used to control your fireplace. You can turn the pilot on or off and you can increase or decrease the flame height.

Note that the thermostat and programming functions are not available with the wall switch.

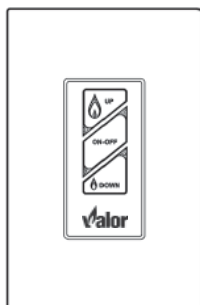

TO ADJUST FLAME HEIGHT

Press and hold large flame  button to gradually increase flame height.

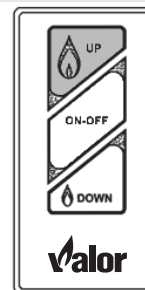

Press and hold small flame  button to gradually decrease flame height.

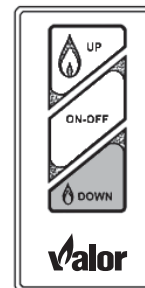

TO TURN APPLIANCE ON and OFF

Press ON-OFF button once to light pilot. Press again to shut of pilot.

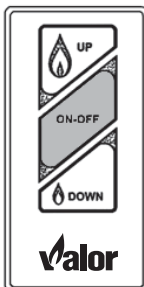

KITS & ACCESSORIES

Required Kits

Information accurate at the time of printing and subject to change without notice.

4006887	LX2 Barrier Screen—Front panel
4006888	LX2 Barrier Screen—Side panel
Fuel Beds (choose one)	
1705DWK	Driftwood Set Kit
2200DGM	Murano Glass Set
2200DGS	Decorative Glass Set
1700SWK	Splitwood Kit
1700RSS	Rocks & Shale Set
Liners + Liner End Panel (choose one)	
2200FBL+ 2200FBP	Fluted Black Liner Set Fluted End Panel
2200RGL+ 2200RGP	Reflective Glass Liner Set Reflective Glass End Panel
2200LML+ 2200LMP	Limestone Liners Limestone End Panel
LDK HeatShift (choose one)	
LDK1	Quad Plenum 48"
LDK3	Double Plenum 14" (2) with Grille
LDK4	Quad Plenum 38"
LDK7	Duct Termination Plates (for valance outlet)

Optional Accessories

Information accurate at the time of printing and subject to change without notice.

Conversion Kits	
2200XNGK	Conversion to natural gas
2200XPGK	Conversion to propane gas
Other Accessories	
LDK2	48" Finishing Frame for LDK1
LDK5	38" Finishing Frame for LDK4
LDK6	5" dia Aluminum 2-ply Flex Kit— 2 x 10'-0" lengths, may be cut to required length
2200ULK	Underbed Lighting Kit (for 2200DGS)
1270RBK	Remote Blower Kit
Hearth Gate	Hearth gates such as Cardinal's VersaGates are available at retail stores carrying safety products for children.

LIGHTING INSTRUCTIONS

FOR YOUR SAFETY, READ BEFORE LIGHTING

WARNING: If you do not follow these instructions exactly, a fire or explosion may result causing property damage, personal injury or loss of life.

- A. THIS APPLIANCE HAS A PILOT WHICH MUST BE LIGHTED BY HAND, REMOTE CONTROL, OR WALL SWITCH. FOLLOW THESE INSTRUCTIONS EXACTLY. TO SAVE GAS, TURN THE PILOT OFF WHEN NOT USING THE APPLIANCE FOR A PROLONGED PERIOD OF TIME.**
- B. BEFORE LIGHTING**, smell all around the appliance area for gas. Be sure to smell next to the floor because some gases are heavier than air and will settle on the floor.
- WHAT TO DO IF YOU SMELL GAS**
- Do not try to light any appliance.
 - Do not touch any electric switch; do not use any phone in your building.
 - Immediately call your gas supplier from a neighbor's phone. Follow the gas supplier's instructions.
 - If you cannot reach your gas supplier, call the fire department.
- C.** Use only your hand to push in or turn the control knobs. Never use tools. If the knobs will not push in or turn by hand, don't try to repair them; call a qualified service technician. Force or attempted repair may result in a fire or explosion.
- D.** Do not use this appliance if any part has been under water. Immediately call a qualified service technician to inspect the appliance and to replace any part of the control system and any gas control, which has been under water.

LIGHTING INSTRUCTIONS

- STOP!** Read the safety information above.
- TO CLEAR ANY GAS, turn main valve off by pressing OFF (red dot) button on remote handset (1).**
 - Wait five (5) minutes to clear out any gas, then smell for gas, including near the floor. **If you smell gas, STOP!** Follow "B" in the safety information above on this label. If you don't smell gas, go to the next step.

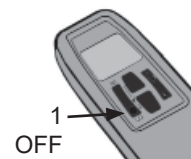

- AUTOMATIC IGNITION:** MAN-knob (2) in ON position. Ensure Flame Adjustment knob (3) is set to lowest setting (U) (Fig. 1). Locate the pilot (Fig. 3.) inside of firebox at left hand side.

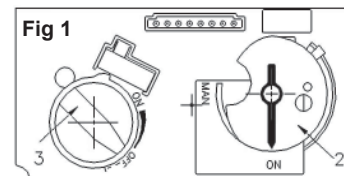

- On the remote control handset, press the OFF button (red dot) and large flame button (🔥) simultaneously; a short acoustic signal confirms the start has begun.
- Further short acoustic signals indicate the ignition process is in progress.
- When the pilot is lit, the Flame Adjustment knob (3) will automatically rotate to the highest setting.
- Press the small flame button (🔥) on the remote control handset to reduce the flame height.

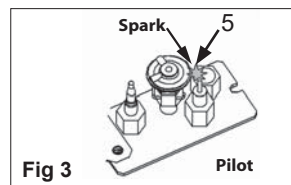

- MANUAL IGNITION:** MAN-knob (2) in MAN position (Fig. 2). With the window off, locate the pilot (Fig. 3) inside of firebox at left hand side.
 - Set Flame Adjustment knob (3) to the lowest setting (U).
 - Push down the metallic core (4) with a pen or similar instrument; this will establish the pilot gas flow.
 - Light gas at the pilot (5) with a match.
 - Continue holding down metal core (4) for about 10 seconds; after release, pilot should remain lit.
 - If the pilot will not stay lit after several tries, turn the gas control knob (3) to OFF (U) and call your local service technician or gas supplier.
 - Reinstall the window and set the MAN-knob (2) to ON; turn Flame Adjustment knob (3) up (U) or down (U) manually or use the flame buttons (🔥) on the remote control handset to adjust the flame height.

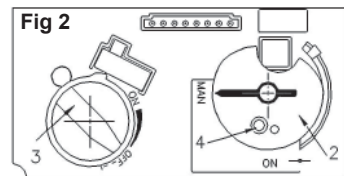

TO TURN OFF GAS TO APPLIANCE

AUTOMATIC SHUT-OFF (using the remote control handset):

- Press and hold the small flame button (🔥) on the remote control handset to shut-off the main burner gas flow.
- Press OFF button (red dot) on remote handset to shut-off the appliance, including pilot flame.

Servicing Your Fireplace

We recommend having your fireplace serviced every year. Contact your supplier quoting the model number. It will be helpful if the appliance's serial number can also be quoted. These numbers are on the information card. The replacement parts are shown at the end of this manual. Please always quote the part number and description when requesting spare parts.

Annual Inspection

In order to maintain the safe operation of your fireplace, contact your dealer to have a qualified technician go over the list below and make the necessary verifications at least once every year.

Safe Operation List

To be performed by a qualified technician only

1. Inspect and operate the pressure relief mechanism to verify relief mechanisms are free from obstruction to operate. See *Cleaning Your Fireplace: To refit the window* section of this manual.
2. Clean glass window with a suitable fireplace glass cleaner. Abrasive cleaners must not be used. Be careful not to scratch the glass when cleaning. See *Cleaning Your Fireplace* section of this manual.
3. Inspect the operation of the flame safety system Pilot or Flame rectification device.
4. Inspect and ensure the lighting of the main burner occurs within 4 seconds of the main gas valve opening. Visual inspection should match that outlined in the appliance instruction manual. Inspect primary air openings for blockage. See *Checking Pilot and Burner Flame* section of this manual.
5. Inspect condition of vent and vent terminal for sooting or obstruction and correct if present.
6. Vacuum and clean any debris in the firebox that is not supposed to be there.
7. Test and measure the flame failure response time of the flame safety system. It must de-energize the safety shutoff in no more than 30 seconds.
8. Check all accessible gas-carrying tubes, connections, pipes and other components for leaks. See *Set up Gas Supply* section of this manual.

MAINTAINING YOUR FIREPLACE

Cleaning Your Fireplace

⚠ WARNING

DO NOT TOUCH THE GLASS WHILE IT IS HOT!
Let the fireplace cool first before cleaning it.

Important - Glass cleaning - Mineral deposits

One of the by-products of the combustion process in a gas appliance is a mineral which can show up as a white film on the ceramic glass of the viewing door.

The composition of the deposit varies with location and time. It is believed to be associated with the varying sulfur content of the gas. You may have the problem intermittently.

We have consulted with ceramic glass manufacturers and they cannot offer a definitive solution to this problem. Dealers have tried various cleaning products with varying results. The following are recommendations only and are not meant to guarantee results.

NOTE: This is a problem beyond Miles Industries' control and is not covered under warranty.

- Clean the glass regularly as soon as you notice the buildup (white film). If the film is left for a longer period of time, it will etch into the glass. It is then much harder, if not impossible, to remove.
- **NEVER use an abrasive cleaner or ammonia-based cleaner on the ceramic glass.** Any abrasion of the surface has the immediate effect of compromising the strength of the glass. An emulsion type cleaner is recommended.
- Use a soft damp cloth to apply the cleaner. Dry the glass with a soft, dry, preferably cotton cloth. Most paper towels and synthetic materials are abrasive to ceramic glass and should be avoided.
- Our dealers have had good results from the products listed below. We cannot, however, guarantee the results of these products.
 - ◊ Brasso, Polish Plus by Kelkem, Cook Top Clean Creme by Elco, White Off by Rutland, Turtle Wax

Do not clean the glass while it is hot!

Always securely replace the window and the barrier screen before lighting.

If broken, the glass pane may only be replaced as a complete window unit as supplied by the manufacturer.

If the barrier becomes damaged, the barrier shall be replaced with the manufacturer's barrier for this appliance.

Clean the window panes following the guidelines in this section.

Clean the steel trim with mild soap and warm water. Any alcohol/solvent base cleaner will weaken the coating and damage it.

Clean the barrier screen dusting it with a soft brush.

Clean the firebox ceramic logs/rocks and walls dusting them with a soft brush. Dust can also be removed from the burner using a soft brush after removing the fuel bed. **When cleaning, make sure that no particles are brushed into the slots of the burner.**

⚠ WARNING

CHOKING HAZARD! Ensure that the fireplace area is clear of fireglass, vermiculite or other media particles as these could be ingested by small children. Vacuum thoroughly around the fireplace area after cleaning.

To remove the window for cleaning—only the front window pane needs to be removed to access the interior of the fireplace:

1. Remove the front barrier screen pull the top first then lifting it out.

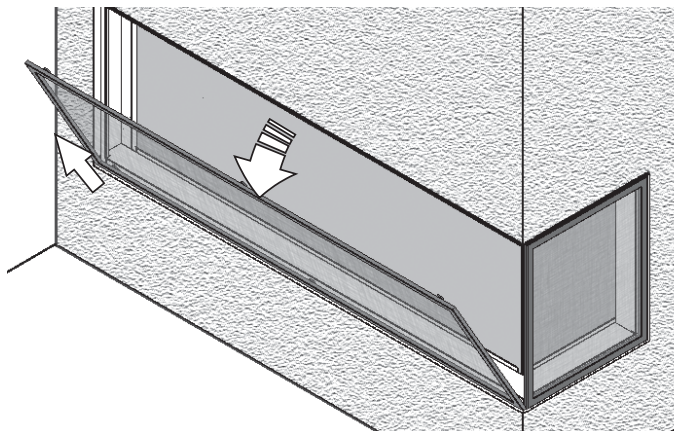

2. Hook the window handle to one of the spring-loaded window levers

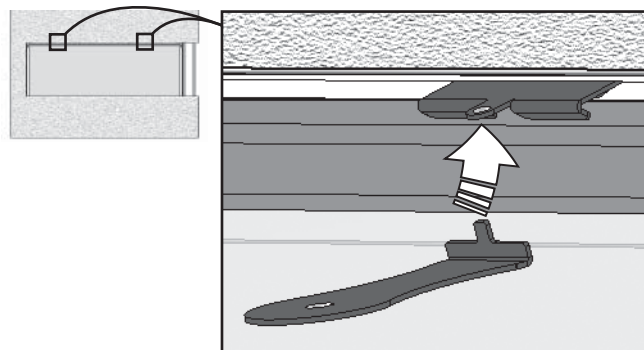

MAINTAINING YOUR FIREPLACE

3. Pull the lever up and unhook the window. Repeat with the other lever.

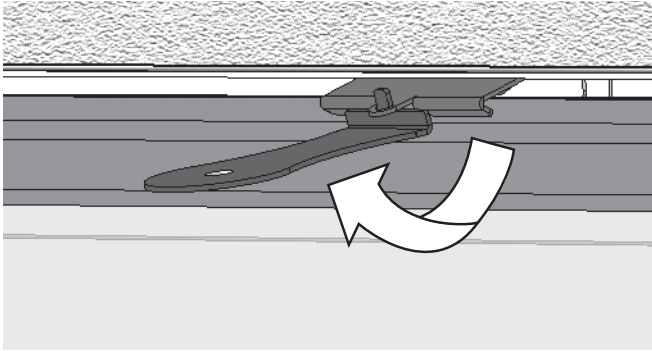

4. Pull the top of the window outward and lift it up behind the front panel to disengage it from its rail.

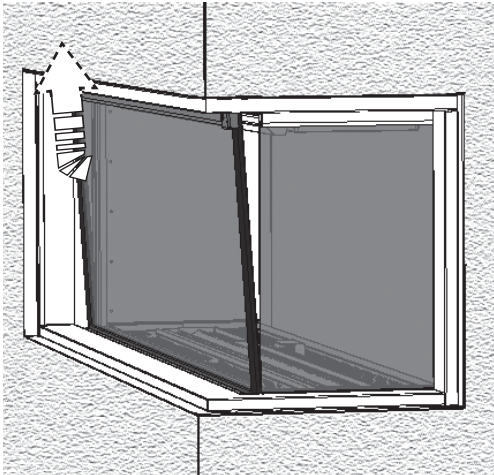

5. Once removed from the bottom rail, rotate the window pane outward to take it out completely; set it aside in a safe place to avoid damage.

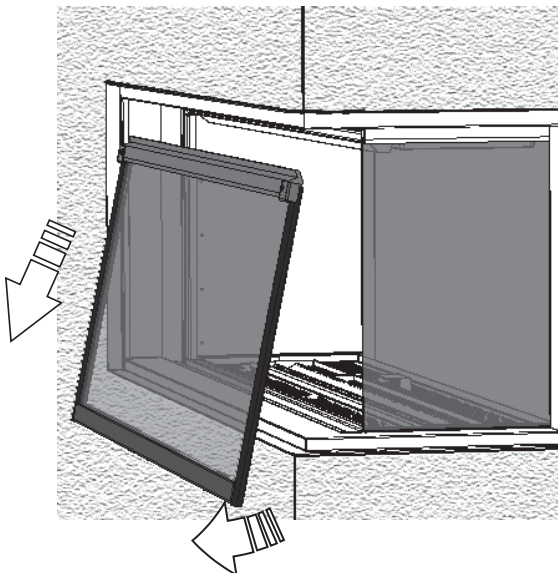

To reinstall the window:

1. Remove any fuel bed media particle from the window bottom rail before installing the window.
2. Ensure the gasket is well fitted to the bottom of the window pane.
3. Insert the window behind the appliance's front panel and lower it into its bottom rail.

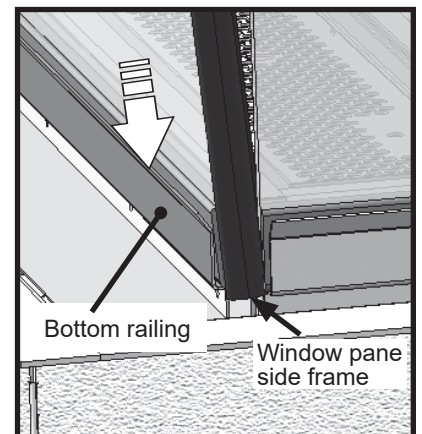
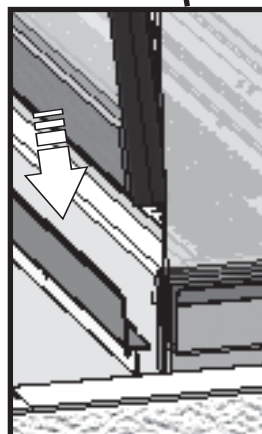
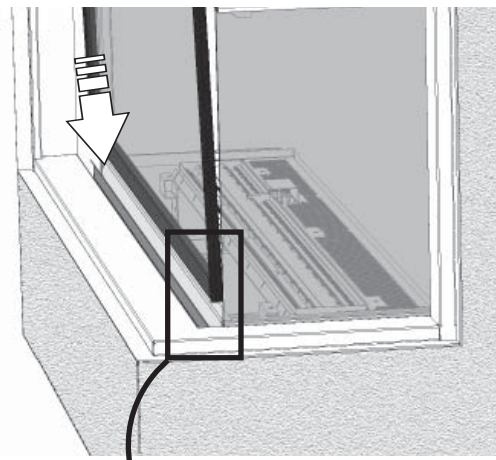
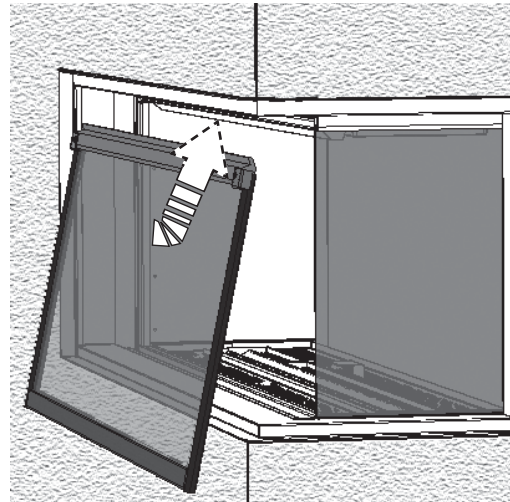

MAINTAINING YOUR FIREPLACE

4. Push the top of the window pane against the firebox. **Ensure it is centered on the firebox so it seals properly.**
5. While you hold it, pull down and hook one of the spring-loaded levers onto the window top black frame using the door handle. Repeat with the other lever.

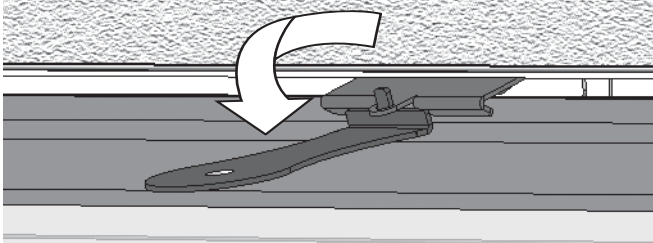

Keep the door handle with the manual for future use.

6. Apply firm hand pressure around the window pane **particularly on the top and sides** to ensure the window is sealed tight against the firebox.

ENSURE THE FRONT WINDOW'S SILICONE GASKETS ARE WELL SEALED, FROM TOP TO BOTTOM, TO THE SIDE WINDOWS!

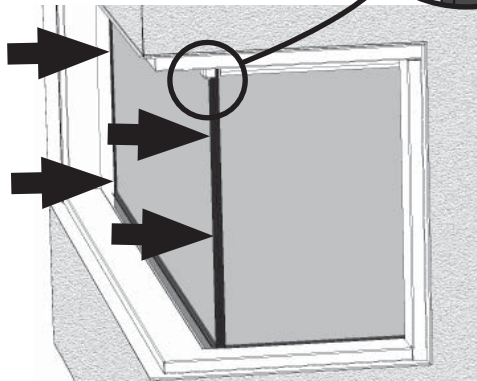
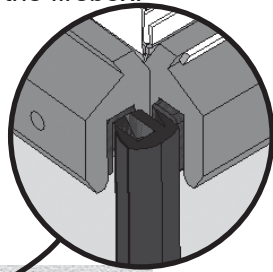

7. If the Hot Glass Warning plate has been removed from the front lower corner of the window, reinstall it by sliding it between the glass and the frame as indicated.

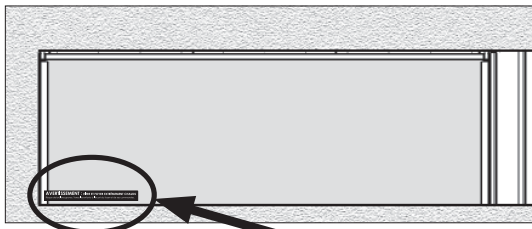

! WARNING: EXTREMELY HOT GLASS AND FIREPLACE
Risk of severe burns. Keep Children away from fireplace & controls.
Risque de brûlures graves. Tenir les enfants et animaux à l'écart du foyer et des commandes.
AVERTISSEMENT : VITRE ET FOYER EXTREMEMENT CHAUDS

! WARNING: EXTREMELY HOT GLASS AND FIREPLACE
Risk of severe burns. Keep Children away from fireplace & controls.

Hot Glass Warning Plate

! DANGER

The window unit must be correctly installed, fastened and sealed after servicing or serious bodily injury and/or damage to the appliance may result.

To ensure a safe operation:

- Double-check that the bottom of the window frame is correctly installed in the bottom support railing;
- Verify that the levers are hooked properly to the window tabs then;
- Pull out the top of the window and release it to insure the springs return it;
- Ensure the window is sealed before operation.

! WARNING

Failure to install the window correctly can leak carbon monoxide, affect the performance of the fireplace, damage components, cause overheating resulting in dangerous conditions. Damage caused by incorrect window installation is not covered by the Valor warranty.

8. Reinstall the barrier screen front panel. Place the screen, magnets inboard, against the ridge of the bottom plate; push the top of the screen against the ridge of the top plate.

! WARNING

FOR SAFETY PURPOSE, ensure the barrier screen is re-installed on the fireplace after maintenance.

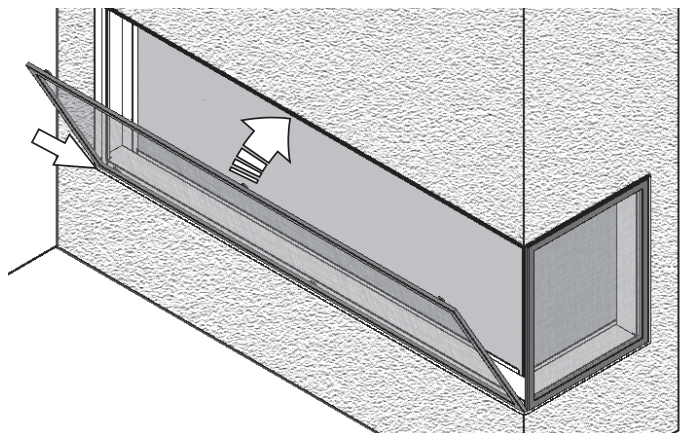

MAINTAINING YOUR FIREPLACE

Checking Pilot and Burner Flames

A periodic check of the pilot and burner flames should be made. Check after the fire has been on for at least 30 minutes. The pilot flame must cover the tip of the thermocouple probe. The main burner flame pattern will vary from appliance to appliance depending on the type of installation and climatic conditions.

The appliance area must always be kept clear and free from combustible materials, gasoline and other flammable vapors and liquids. Inspect the vent terminal outdoors regularly to make sure that snow, trees, bushes, leaves, or other objects do not obstruct it. Examine the vent system and terminal regularly. We recommend annually.



Long Beach Driftwood Kit Correct Flame Picture

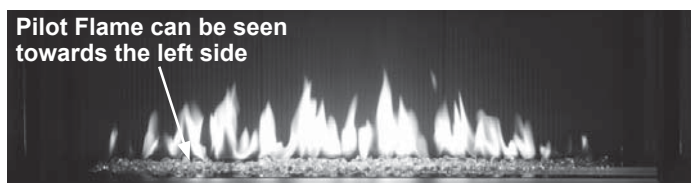

Murano Glass Fire Correct Flame Picture



Decorative Glass Set Correct Flame Picture



Splitwood Kit Correct Flame Picture



Rock & Shale Kit Correct Flame Picture

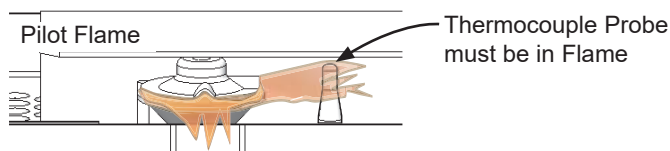

Replacing Batteries

The fireplace requires electrical power which will power the upper lighting (supplied) as well as the remote control receiver. The handset needs a battery.

If you wish to have batteries operating the fireplace in case of a power outage, insert batteries in the Remote battery and Wall Switch (supplied) installed near the fireplace.

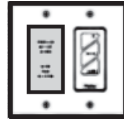

Battery holder & wall switch

DO NOT PUT BATTERIES IN THE RECEIVER OF THE FIREPLACE!
They will overheat and leak.

CAUTION

DO NOT USE a screwdriver or other metallic object to remove the batteries from the battery holder or the handset! This could cause a short circuit.

Low batteries signal: see page 14.

BEFORE changing the batteries, turn the fireplace off (including pilot).

The appliance uses four 1.5 V AA **alkaline** batteries located next to the wall switch and one 9 V **alkaline** battery in its handset. Batteries should last one to two seasons, depending on usage. Removing the batteries in the off-season will extend the battery life.

To replace the batteries:

The battery compartment is located next to the wall switch in the vicinity of the fireplace. Its front plate is attached with magnets to the wall switch box.

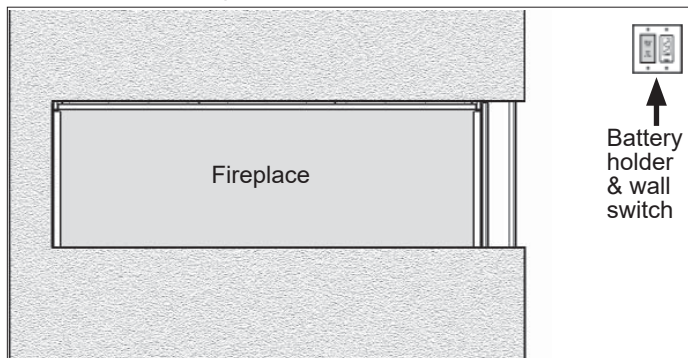

The battery holder is located beside the wall switch.

1. Pull on the plate next to the wall switch to access the batteries.

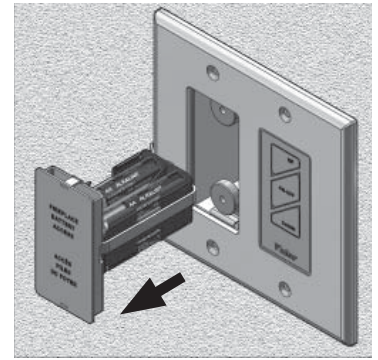

2. Disconnect the snap connector from the battery holder. **Do not pull the connector by the wire!**

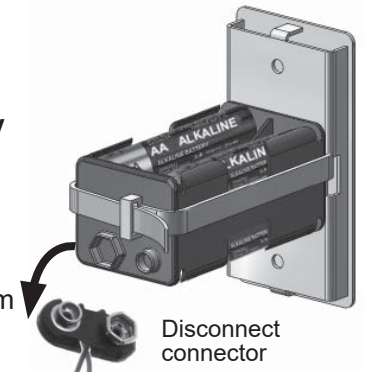

3. Replace the batteries with 4 AA **alkaline** batteries orienting them as indicated inside the holder.

4. Reconnect the snap connector to the battery holder.
5. Put the battery holder back in its place beside the wall switch and snap it in place.

Using Remote Control Handset Wall Holder

Your fireplace equipment includes a wall holder to store the handset. If it hasn't been installed, refer to the instructions further on in this manual for the installation.



Replacing Light Bulbs

Overhead Lighting (3 light bulbs)

The appliance is equipped with a decorative lighting located above the fuel bed. To replace the light bulbs, follow these steps:

1. Remove the front glass window.
2. Locate the light fixture above the firebed.

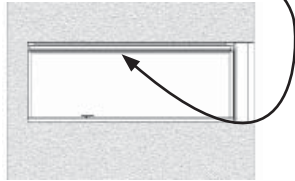

3. Turn off the lighting using the remote control handset.
4. Remove the burned light bulbs from their sockets by gently pulling on them sideways.
5. With a gloved hand, replace with new light bulbs using only a **20 watts halogen 120 volts (type GY6.35 base bi-pin)**.



6. Test the bulbs by turning the lighting on.
NOTE: If the bulbs are new and not functioning, turn off the remote control lighting and call your dealer for inspection.
7. Reinstall the front window.

Underbed lighting (14 light bulbs) (if used)

If the 2200ULK—Underbed Lighting Kit has been installed, you can replace the burned light bulbs in the following manner.

1. Remove the front glass window.
2. Remove the fuel bed.
3. Remove the media trays, front and back (3 screws each).
4. Locate the light fixture below the firebed.

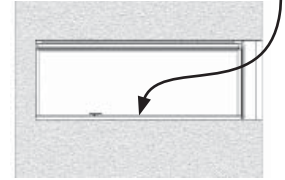

5. Turn off the underbed lighting using the wall dimmer switch.
6. Remove the burned light bulbs from their sockets by gently pulling on them towards the center.
7. With a gloved hand, replace with new light bulbs using only a **20 watts halogen 120 volts (type GY6.35 base bi-pin)**.



8. Test the bulbs by turning the lighting on.
NOTE: If the bulbs are new and not functioning, turn off the dimmer switch and call your dealer for inspection.
9. Replace the media front and rear trays.
10. Reinstall the fuel bed—see the instructions to install the fuel beds in this manual.
11. Refit the window.

SPECIFICATIONS

Approval & Codes

This appliance is certified to ANSI Z21.88-2017/CSA 2.33-2017 American National Standard / CSA Standard for *Vented Gas Fireplace Heaters* for use in Canada and USA, and to CGA 2.17-91 *High Altitude Standard in Canada*. This appliance is for direct vent installations.

This appliance complies with CSA P.4.1-15 *Testing method for measuring annual fireplace efficiencies*.

The installation must conform to local codes or, in the absence of local codes, with the *National Fuel Gas Code, ANSI Z223.1/NFPA 54* or the *Natural Gas and Propane Installation Code CAN/CGA-B149.1*. Only qualified licensed or trained personnel should install this appliance.

This appliance must be electrically grounded in accordance with local codes, or, in the absence of local codes, with the *National Electrical Code, ANSI/NFPA 70* or the *Canadian Electrical Code, CSA C22.1*.

Ratings

Model	JN	JP
Gas	Natural	Propane
Altitude (Ft.)*	0-4,500 feet*	
Input Maximum (Btu/h)	36,000	36,000
Input Minimum (Btu/h)	19,000	21,000
Manifold Pressure (in w.c.)	4.0"	9.5"
Minimum Supply Pressure (in w.c.)	5"	11"
Maximum Supply Pressure (in w.c.)	10"	14"
Main Burner Injector Marking	DMS#32	DMS#49
Pilot Injector Marking	51	30
Min. Rate By-Pass Screw	220	160

*High Altitude Installations

Input ratings are shown in BTU per hour and are certified without deration for elevations up to 4,500 feet (1,370 m) above sea level.

For elevations above 4,500 feet (1,370 m) in USA, installations must be in accordance with the current ANSI Z223.1 and/or local codes having jurisdiction. Heating value of gas in some areas is reduced to compensate for elevation—consult your local gas utility to confirm.

For installations at elevations above 4,500 feet (1,370 m) in Canada, please consult provincial and/or local authorities having jurisdiction.

Supply Gas

Heater engines 2200LJN/2200RJN are used with natural gas.

Heater engines 2200LJP/2200RJP are used with propane gas.

The supply pressure must be between the limits shown in the *Ratings* section above.

The supply connection is 1/2" NPT male and located on the rear left side of the firebox. A shut-off valve (supplied) is required on the supply line to isolate the unit during service. See *Supply Gas Installation* section for details.

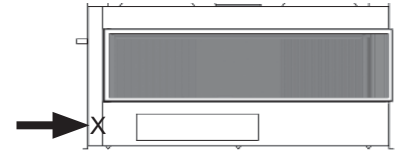

Conversion Kits

The 2200J LX2 is supplied as natural gas or propane gas and is field convertible between fuels. See instructions packaged with the conversion kit for further information.

Electrical

The 2200J is designed to run on battery power and does not require an electrical power source to operate as a heater. However, it requires electrical power to operate the interior lighting, the optional 2200ULK Underbed Lighting Kit or 1270RBK Remote Blower Kit.

LDK HeatShift Duct Kit

The 2200 MUST be installed with the LDK HeatShift Duct Kit, a convection system that redistributes the warm air flow away from the fireplace opening to a more desirable location using natural convection, without use of a fan.

The warm air flow may be relocated to a position higher up the wall, out the sidewalls, or even to another room.

The result is much cooler wall temperatures above the fireplace opening for locating televisions, artwork, etc.

Refer to the installation manual packed with the kit for more information.

This appliance is designed and approved as a supplemental heater and provides the potential for most energy conservation when used while attended. The use of an alternate primary heat source is advisable.

OVERVIEW

⚠ WARNING

Ensure weight of wall above is NOT carried by the appliance.

Vent collar supplied as 5 x 8" outlet, field convertible to 4 x 6-5/8" outlet (adapter supplied). Note - Vertical rise required in vent system when adapting to 4 x 6-5/8" venting

HeatShift Plenum (front or sides) or Duct Termination Plates (top) **mandatory!** HeatShift system supplied separately—see instructions packed with kits

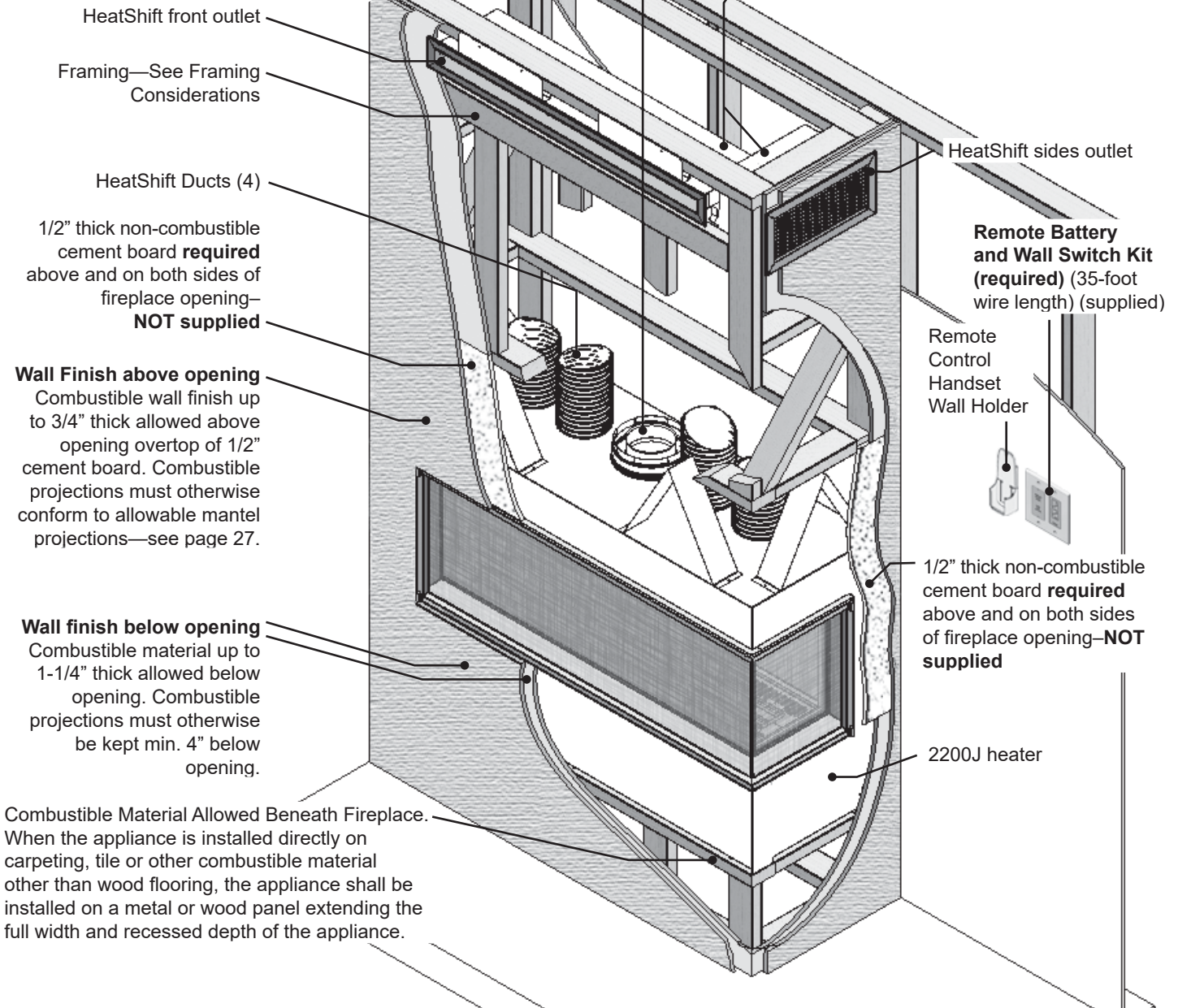

⚠ WARNING

Some materials or items, although safe, may discolor, shrink, warp, crack, peel, and so on because of the heat produced by the fireplace. Avoid placing candles, paintings, photos, and other items sensitive to heat around the fireplace.

⚠ WARNING

HOT WALL SURFACES! The walls directly above the fireplace are constructed of non-combustible materials and, although safe, it may reach temperatures in excess of 175° F depending on choice of materials. Do not touch. Finish the walls using materials suitable for these temperatures.

DIMENSIONS & LOCATION

Dimensions—Corner Right Appliance Shown

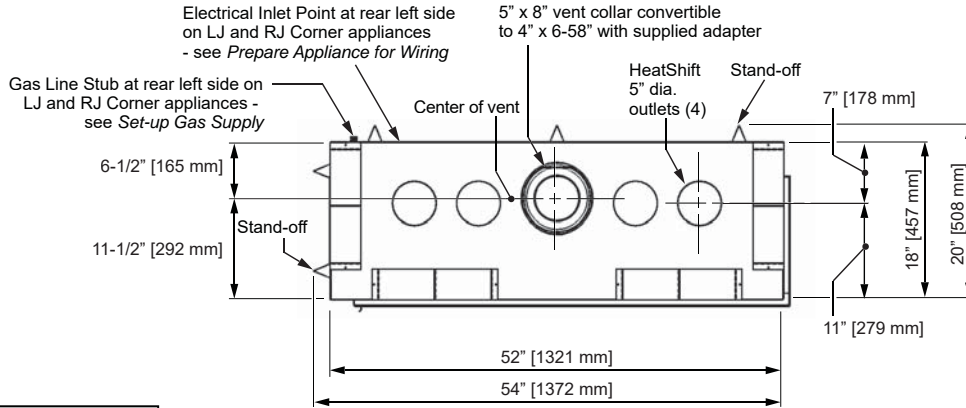

Gas Line Stub & Electrical Inlet Point at rear, on left side for both LJ and RJ corner appliances

**Top View
(corner right appliance shown)**

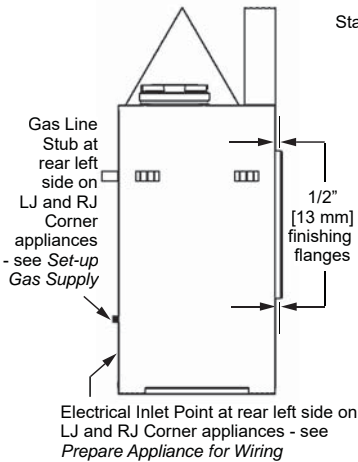

Side View

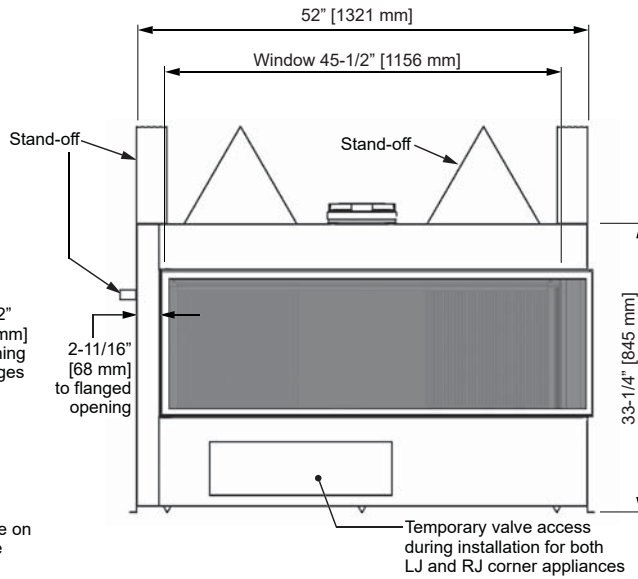

**Front View
(corner right appliance shown)**

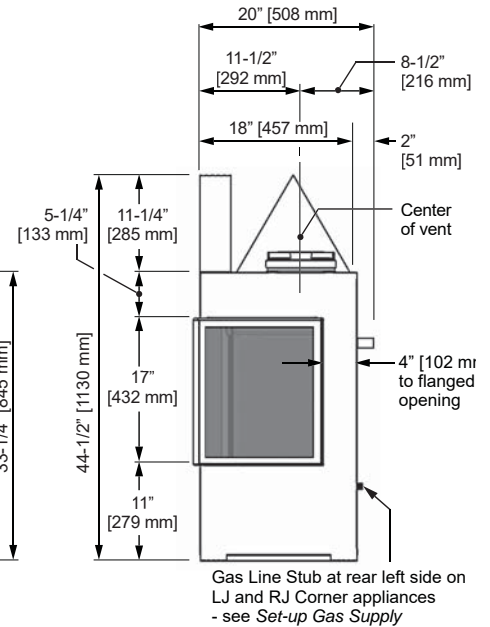

Side View

Location—Corner Right Appliance Shown

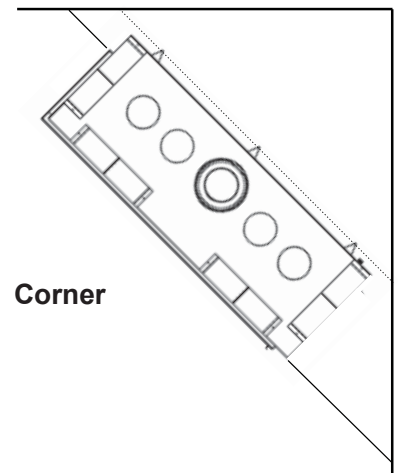
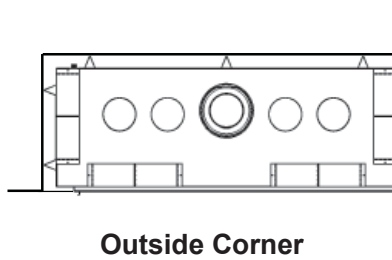
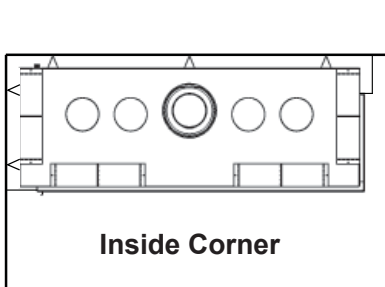

CLEARANCES TO COMBUSTIBLE PROJECTIONS

⚠ WARNING

Ensure weight of wall above is NOT carried by the appliance.

 Non-combustible material

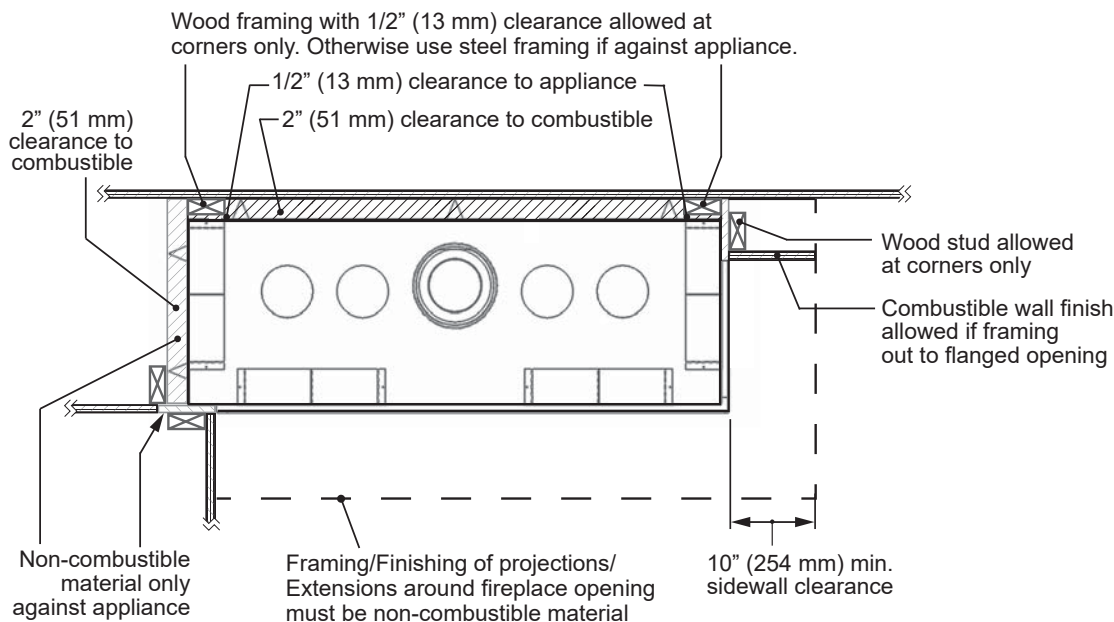

Combustible projections allowed in this area provided area is separated from the main cavity by non-combustible wall finish. Otherwise everything below stand-off height and within cavity must be non-combustible.

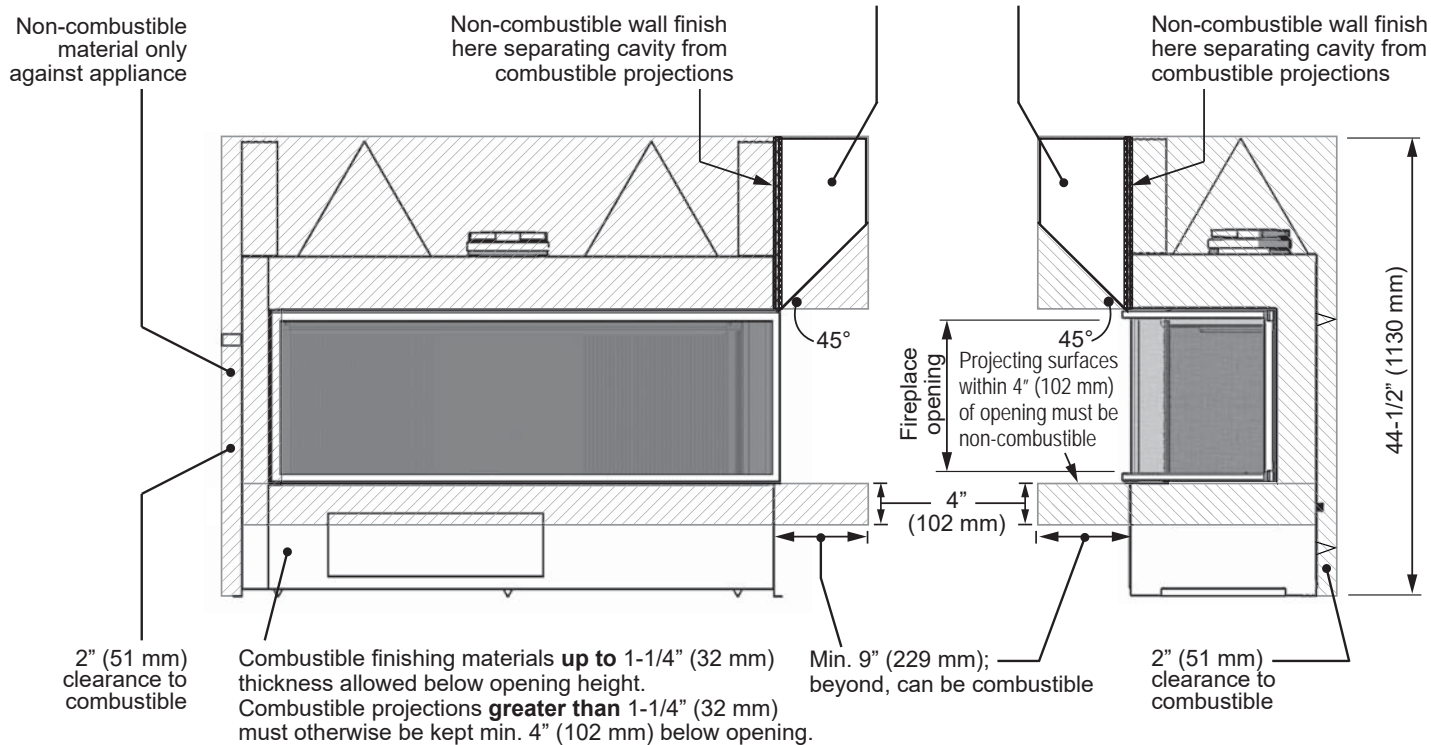

FRAMING CONSIDERATIONS

Minimal Framing

⚠ WARNING

Ensure weight of wall above is NOT carried by the appliance.

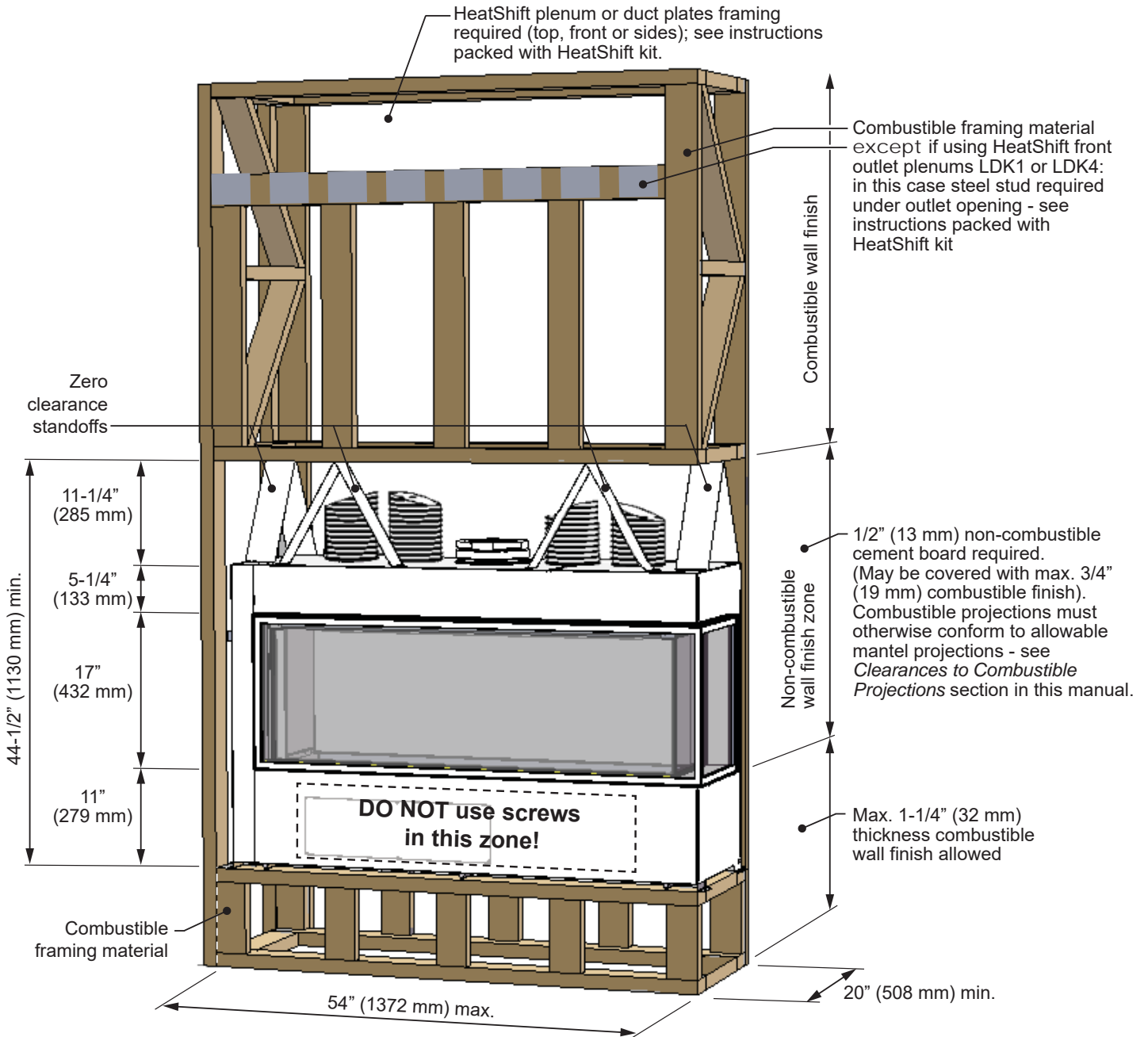

FRAMING CONSIDERATIONS

Extended Framing (steel framing required)

WARNING

Ensure weight of wall above is NOT carried by the appliance.

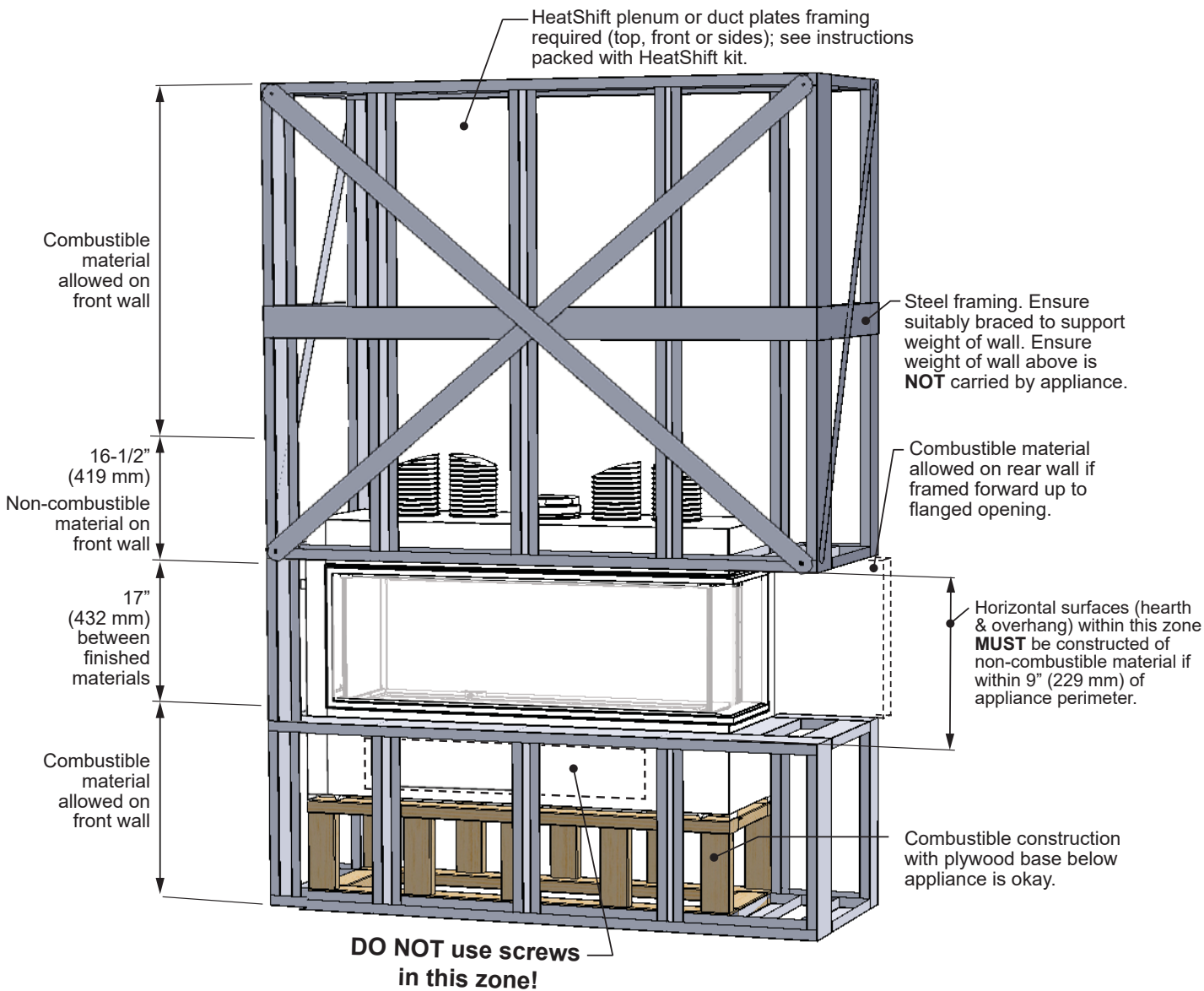

FRAMING CONSIDERATIONS

Alcove above opening

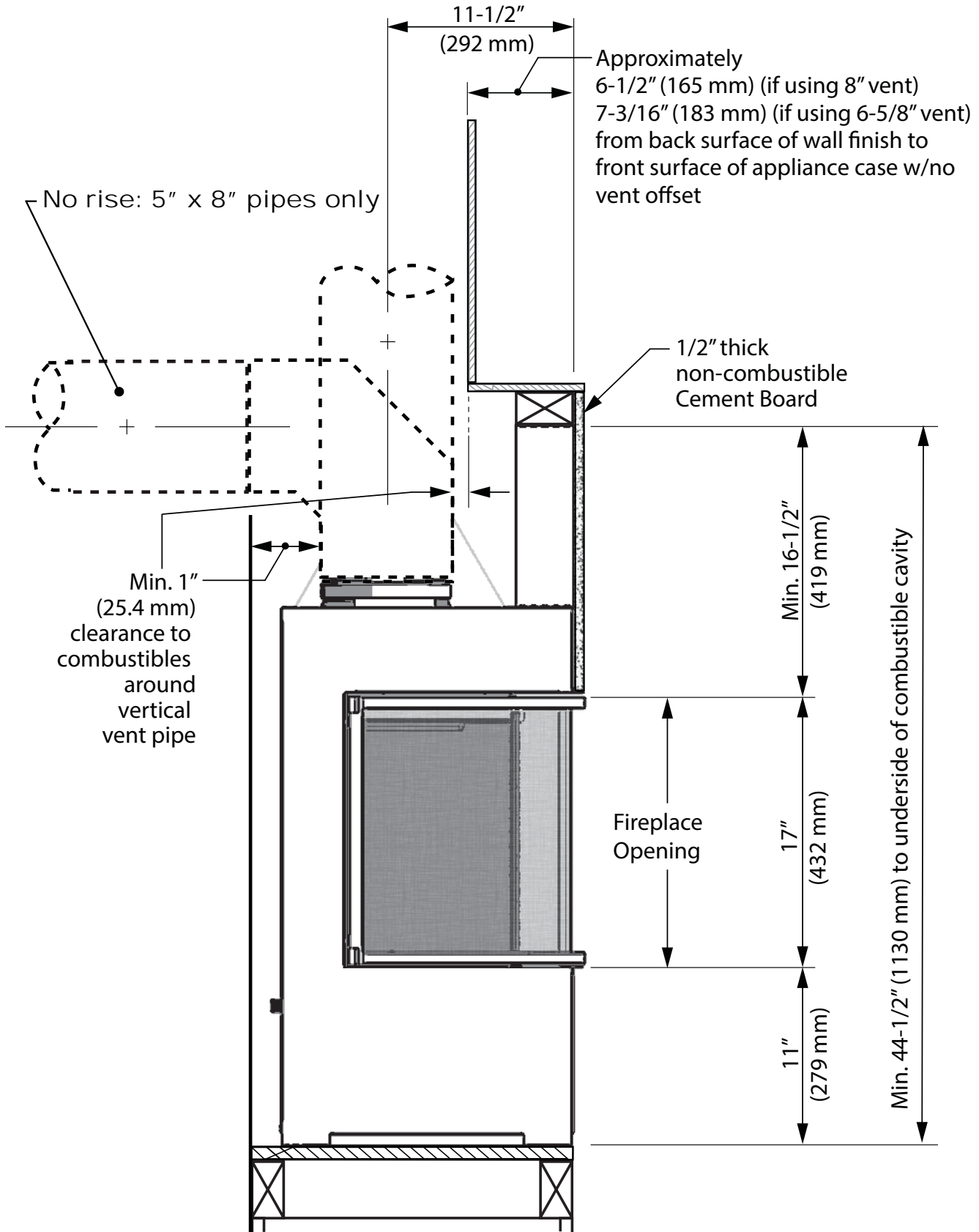

FRAMING CONSIDERATIONS

Minimum Vertical 6-5/8" Vent

* This is the minimum vent height when using 6-5/8 inch venting. If calculating the vent height using **additional** vent lengths, subtract approximately 1-1/2 inch for each pipe joint. For example, an **additional** 12-inch pipe section will add approximately 10-1/2 inches overall to this dimension. Alternatively, **substituting** a 24-inch pipe length for the min. 12-inch section will add 12 inches to this dimension as there is no additional pipe joint.

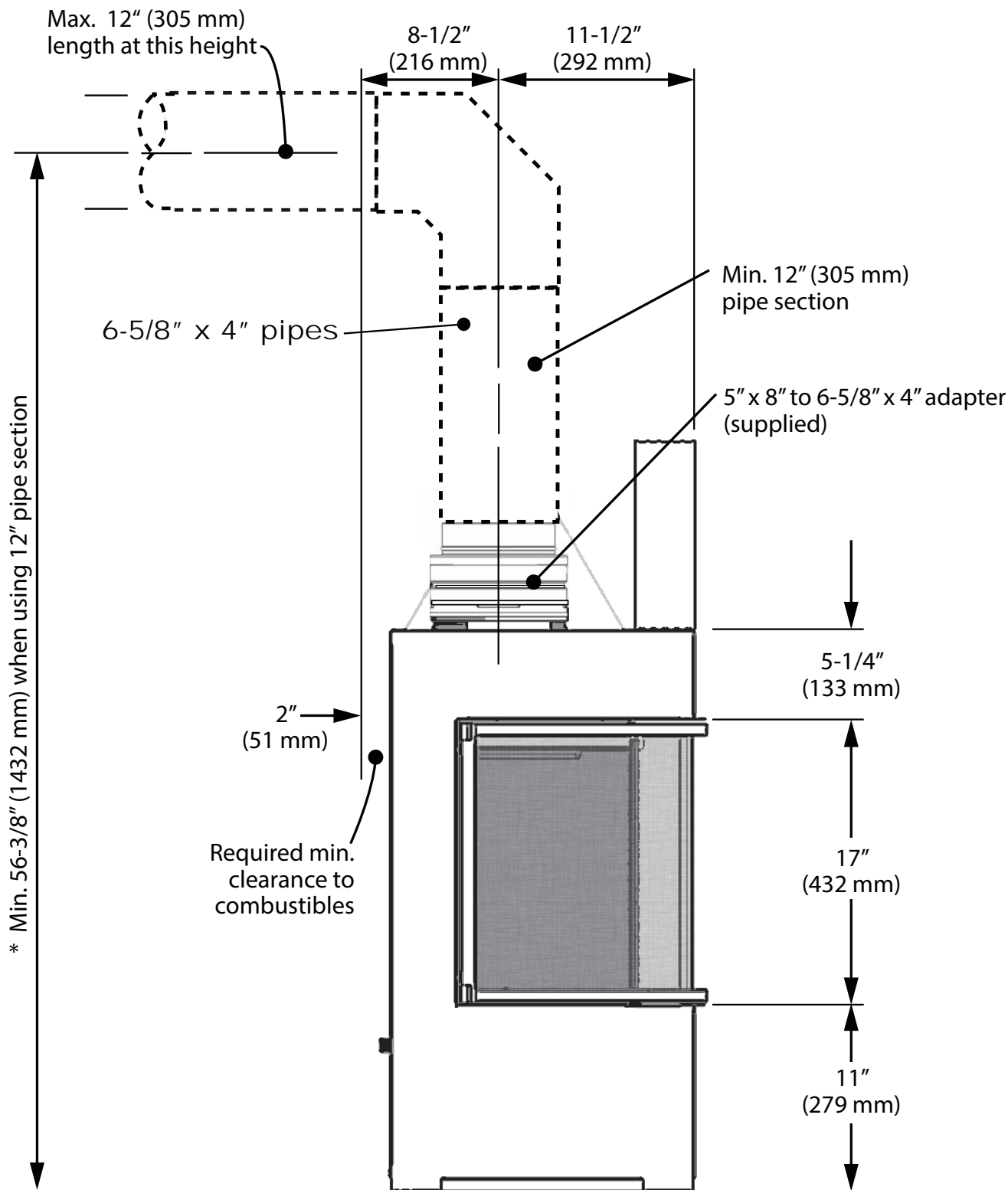

FRAMING CONSIDERATIONS

Minimum Vertical 8" Vent

* This is the minimum vent height when using 8-inch venting. If calculating the vent height using **additional** vent lengths, subtract approximately 1-1/2 inch for each pipe joint. For example, an **additional** 12-inch pipe section will add approximately 10-1/2 inches overall to this dimension.

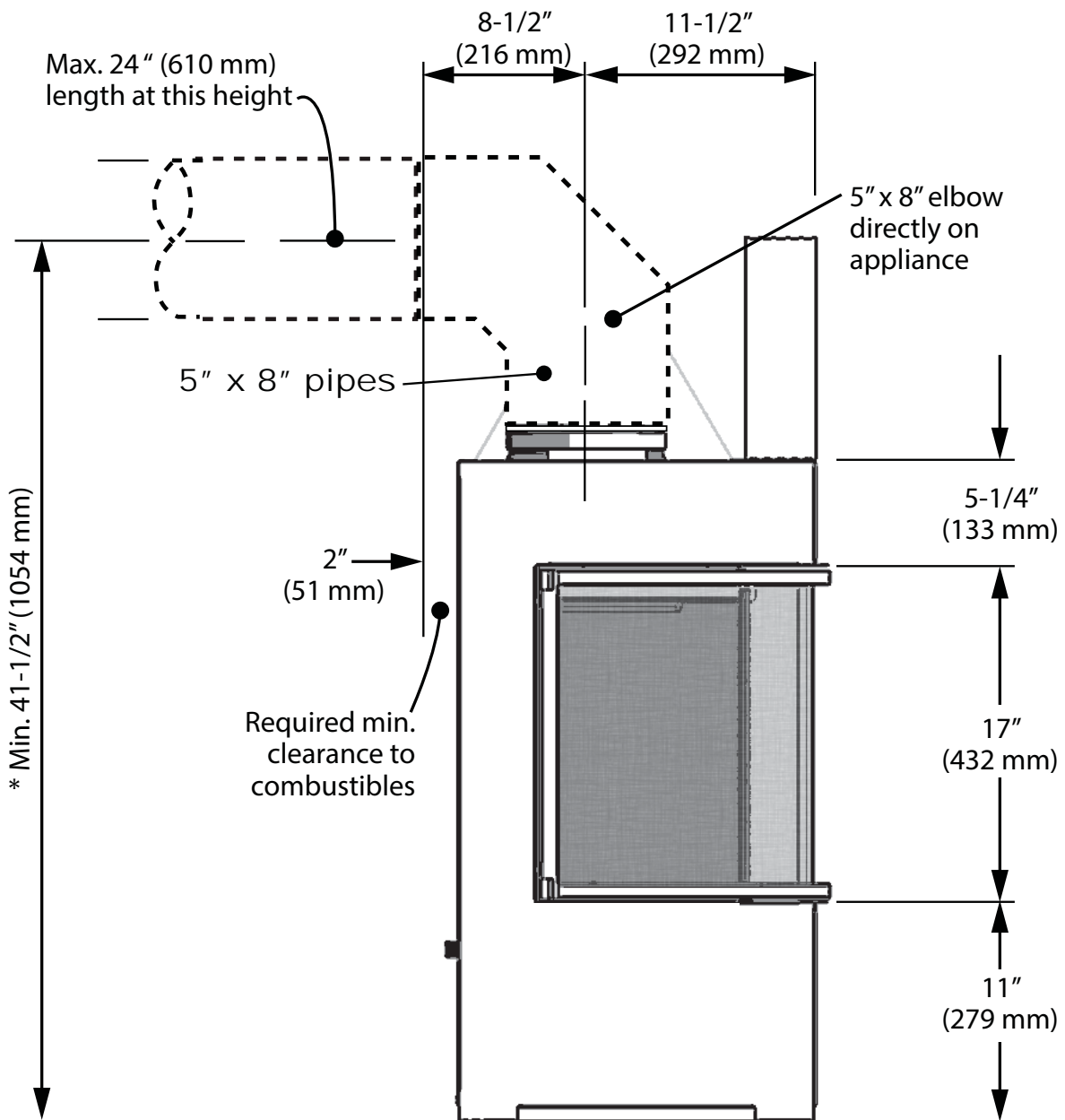

VENTING

Vent Material

This unit is approved for installation using 5 x 8 inches co-axial direct vent pipe and accessories as listed in the *Approved Venting Components* section on pages 68–69 of this manual. Follow the installation instructions supplied with the individual venting accessories.

This unit may also be converted to 4 x 6-5/8 inches co-axial direct vent pipe and accessories using the adapter supplied with the appliance—see list in the *Approved Venting Components* section on pages 68–69 of this manual.

Vent Sealing

Seal all outer coaxial pipe and elbow joints, including sectioned elbow joints, using high quality, high temperature 2 inch wide self-adhesive aluminum foil tape (Nashua-322-2 brand or similar). Wrap the tape completely around all joints and press firmly to seal.

A high temperature black silicone sealant may be used in the outer joints as a substitute to foil tape.

Ensure all the pipe joints have a minimum of 1 ¼ inch overlap.

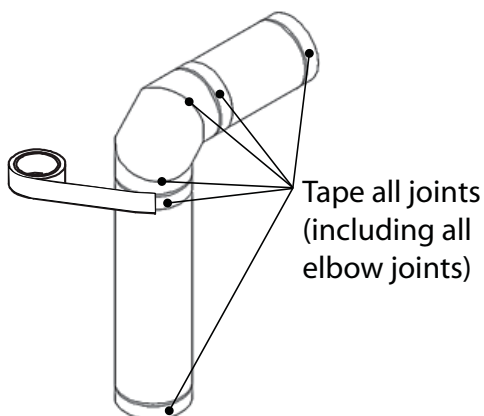

Wall Thickness

The appliance vent is suitable for penetrating a combustible wall assembly up to 8 inches in thickness. A non-combustible wall can be of any thickness up to the maximum horizontal run of vent pipe allowed for the particular installation.

Framing Vent in Combustible Walls & Ceilings (6-5/8" and 8" pipes)

When penetrating through combustible walls and ceilings, frame a **minimum of 10 in x 10 in** opening and ensure that the insulation is kept clear of the vent pipe using either a wall thimble or an attic insulation shield. Note that some vent manufacturers' wall thimble dimensions may require larger framed openings—follow the installation instructions supplied with the individual venting components.

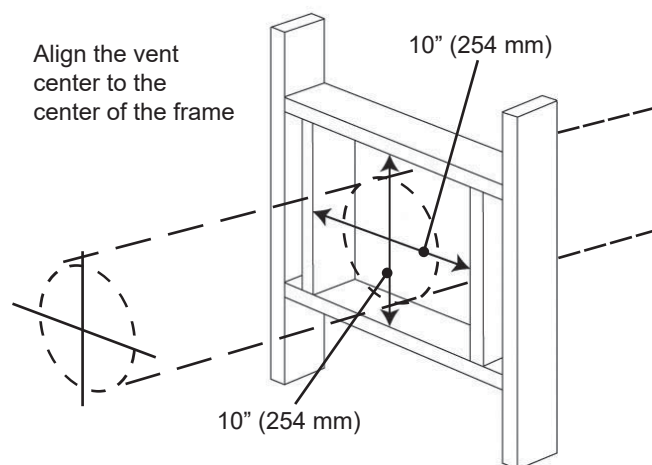

Important Installer Notice – Weather Sealing & Vapor Barriers

It is the installer's responsibility to ensure that vent installations through exterior walls are caulked and weatherproofed in such a manner as to:

- Prevent rain water from entering the wall from the weather side by adequately caulking the outer vent plate to the exterior wall surface.
- Prevent moisture inside the home from penetrating into the wall structure by ensuring the inside wall plate is adequately sealed to the inside vapor barrier.
- Prevent rain water and moisture from entering the walls by sealing the joints between the outer vent tube and the inner and outer wall plates.

We recommend the use of a high quality polyurethane sealant.

All horizontal pipe runs must be graded 1/4 inch per foot upwards in the direction of the exhaust flow. The final pipe length, when terminating through the wall may be graded downwards slightly to prevent water migration.

VENTING

Typical Co-axial Venting Components

Appliance provided with 5 x 8" vent collar and 4 x 6-5/8" vent adapter.

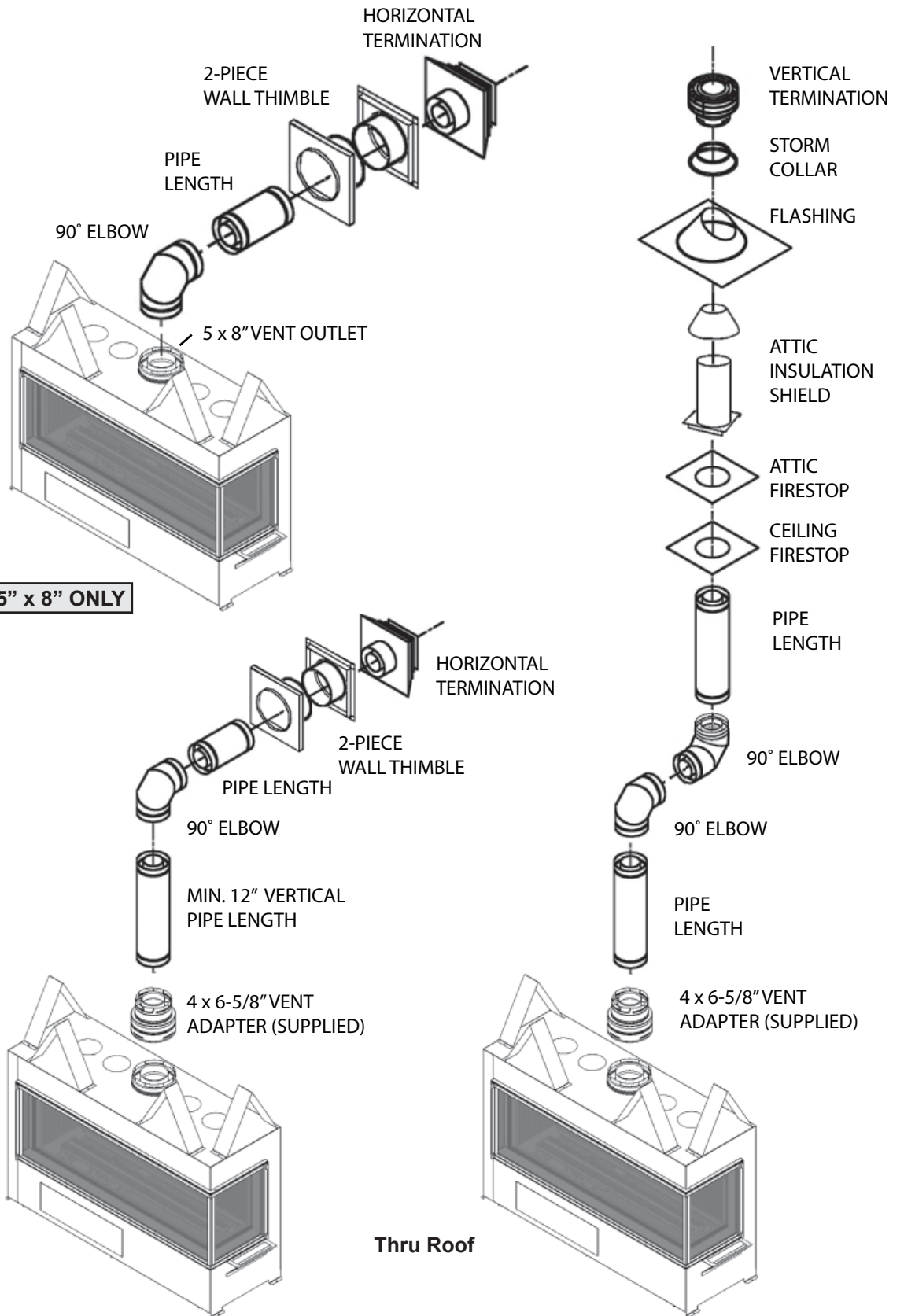

VENTING

4" x 6-5/8" Venting

How to Read the Venting Chart

The chart below applies to co-axial roof or wall termination.

1. Minimum 12 inch vertical pipe section required right at unit when using 6-5/8" venting.
2. The total length of the vent pipe cannot exceed 40 feet.
3. The minimum vertical height with roof termination is 6 feet.
4. Any combination of rise and run can be used as long as they are within the allowable limits shown on the chart below.
5. A maximum of 4 x 90 degrees elbows—or equivalent (2 x 45 degrees = 90 degrees)—can

6. Each 90 degrees elbow installed on the horizontal plane is equivalent to a 3 feet horizontal pipe; therefore, 3 feet must be subtracted from allowable horizontal run. (45 degrees elbow is equivalent to 18 inches horizontal pipe.)
7. All horizontal pipe runs must be graded 1/4 inch per foot upwards in the direction of the exhaust flow. The final pipe length, when terminating through the wall may be graded downwards slightly to prevent water migration.
8. A restrictor adjustment is required for most installations having a vertical rise—see next section.

Note: The restrictors are shipped installed at the exhaust exit of the firebox.

Venting Chart with 4" x 6-5/8" pipes

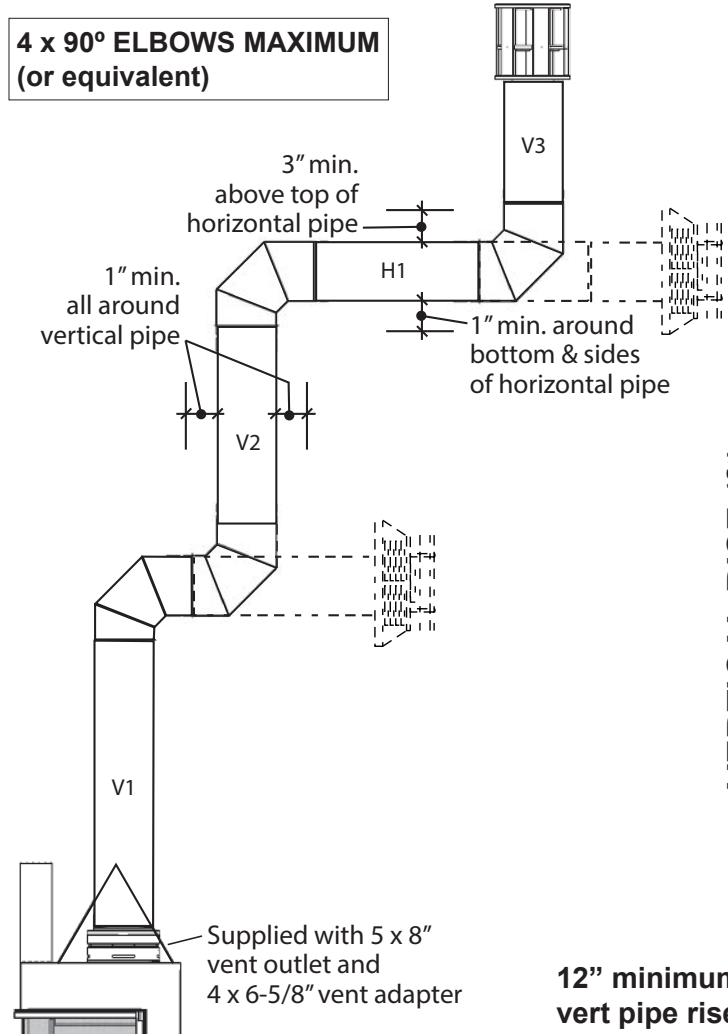

**Allowable Co-Axial Vent Configurations with restrictor positions—
Chart for 4" x 6-5/8" Venting ONLY**

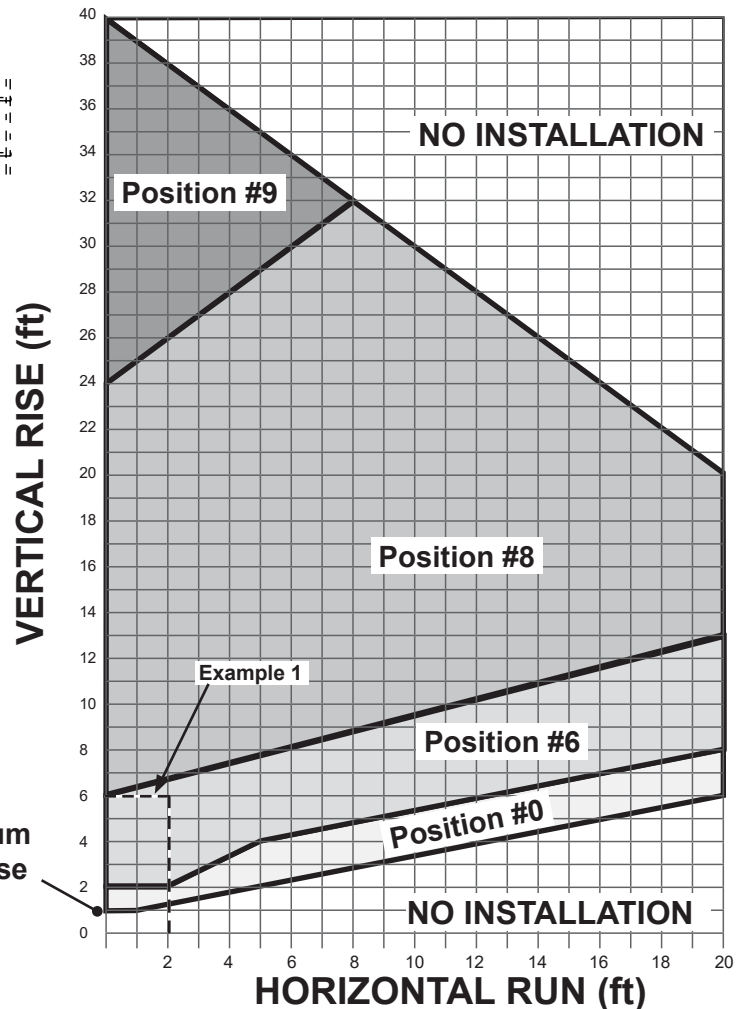

Example 1
 $V \text{ Value} = V1 (3') + V2 (2') + V3 (1') = 6'$
 $H \text{ Value} = H1 (2') = 2'$
 Restrictor position # 6 required

VENTING

5" x 8" Venting

How to Read the Venting Chart

The chart below applies to co-axial roof or wall termination.

1. Maximum 24 inch horizontal pipe section allowed when using a 90 degrees elbow directly at the appliance.
2. The total length of the vent pipe cannot exceed 40 feet.
3. The minimum vertical height with roof termination is 6 feet.
4. Any combination of rise and run can be used as long as they are within the allowable limits shown on the chart below.
5. A maximum of 4 x 90 degrees elbows—or equivalent (2 x 45 degrees = 90 degrees)—can be used. Excludes the 45 degrees take-off elbow shipped with the appliance.

Venting Chart with 5" x 8" pipes

**4 x 90° ELBOWS MAXIMUM
(or equivalent)**

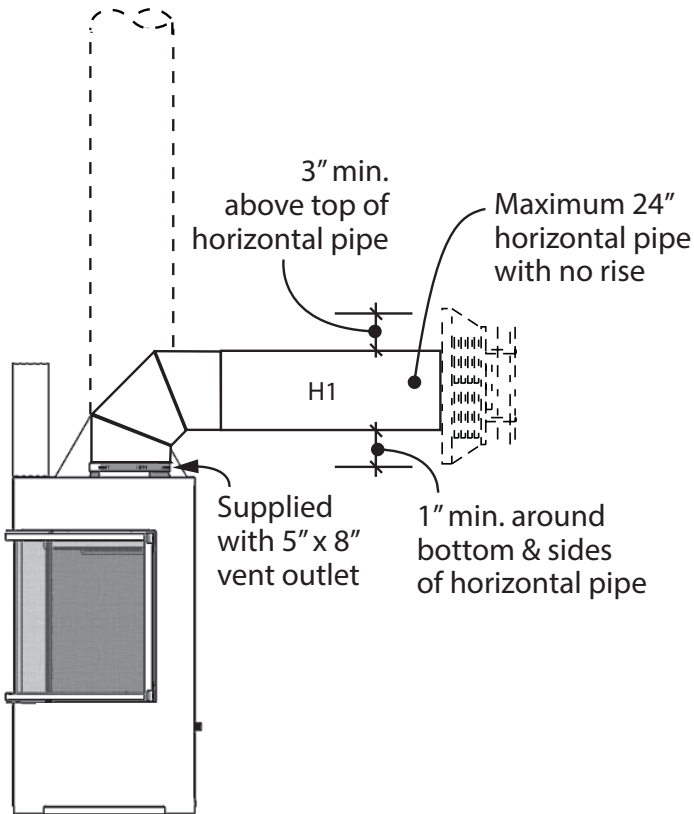

6. Each 90 degrees elbow installed on the horizontal plane is equivalent to a 3 feet horizontal pipe; therefore, 3 feet must be subtracted from allowable horizontal run. (45 degrees elbow is equivalent to 18 inches horizontal pipe.)
7. All horizontal pipe runs must be graded 1/4 inch per foot upwards in the direction of the exhaust flow. The final pipe length, when terminating through the wall may be graded downwards slightly to prevent water migration.
8. A restrictor adjustment is required for most installations having a vertical rise—see next section.

Note: The restrictors are shipped installed at the exhaust exit of the firebox.

**Allowable Co-Axial Vent Configurations
with restrictor positions—
Chart for 5" x 8" Venting ONLY**

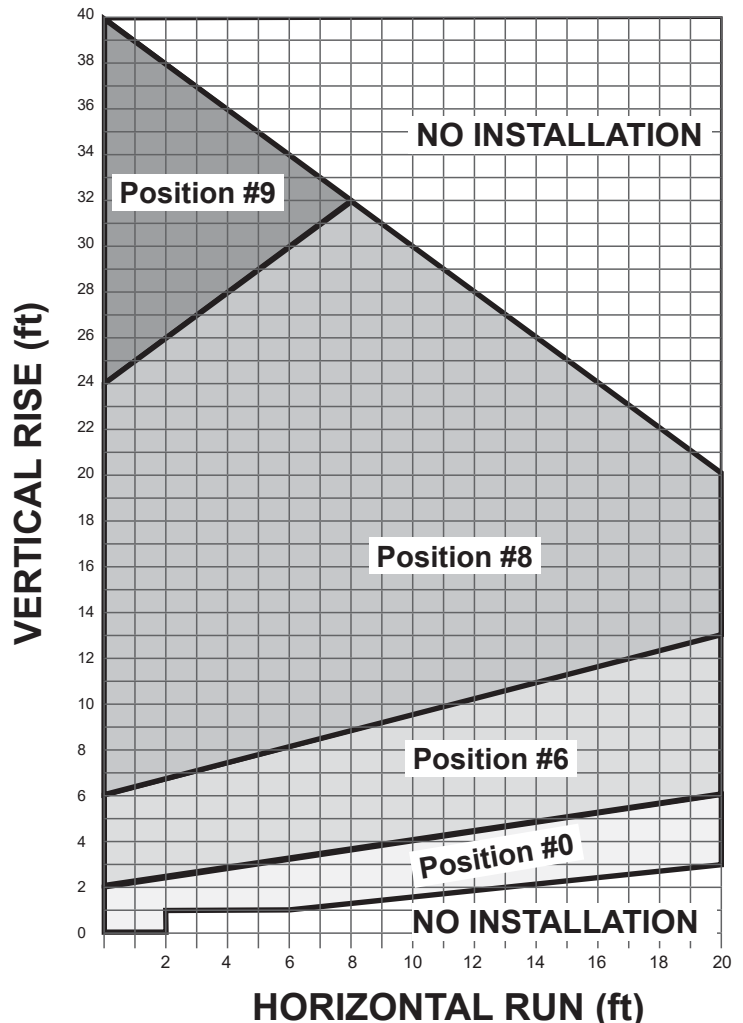

Restrictors

ALL INSTALLATIONS REQUIRE A RESTRICTOR for improved flame picture and performance. This unit is supplied with a pre-fitted restrictor having different positions or settings. The restrictor is shipped mounted at the maximum open position. The level of restriction required depends on the vertical rise in the venting system and, to a lesser degree, the horizontal run and number of elbows.

The amount of restriction is based on laboratory tests. The ideal restrictor position may vary slightly, especially when the vent pipe length is near the limits of the acceptable configurations for each type of restrictor.

The chart on the previous page shows the vent restrictor required relative to the length of the vent pipe.

The restrictors are located in the roof of the firebox hidden above the top panel.

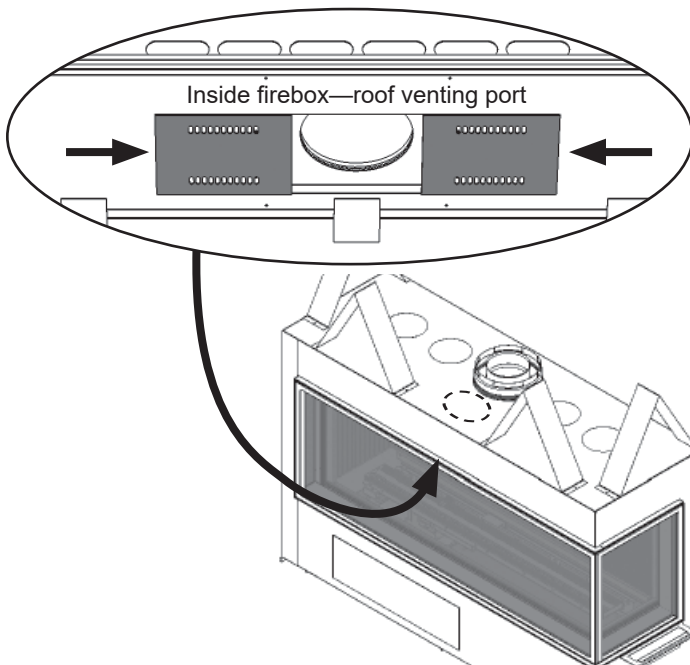

To access the restrictors, remove the top panel:

1. Release 4 screws along the back of the panel. **It is not necessary to remove the screws.**

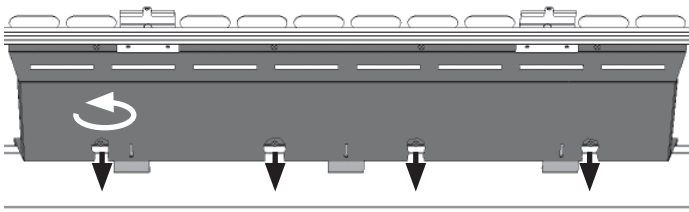

2. Remove 4 screws along the front of the panel.

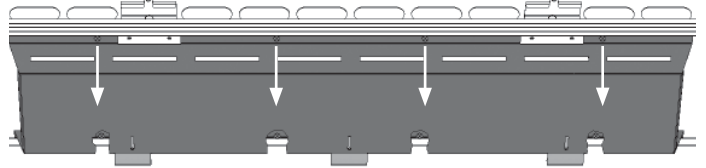

3. Slide the panel forward to unhook it and set aside.
4. The restrictors are set in position 0 at the factory. The position 0 is at the center and has the restrictors wide open; the position 10 is the farthest away from the center and has the restrictor closed totally. Adjust the restrictors position as needed—up to position 9—

DO NOT CLOSE ALL THE WAY TO POSITION 10!

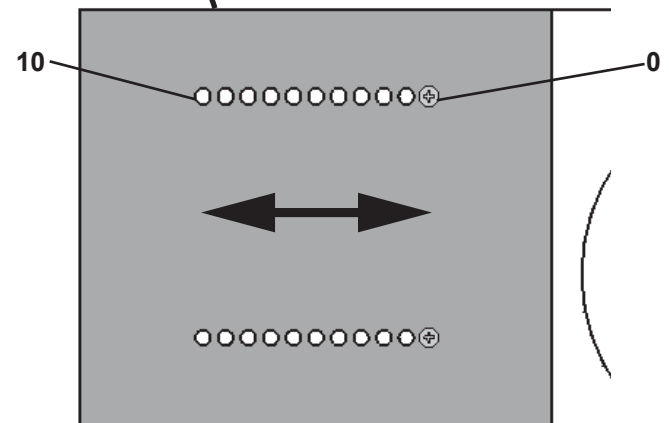
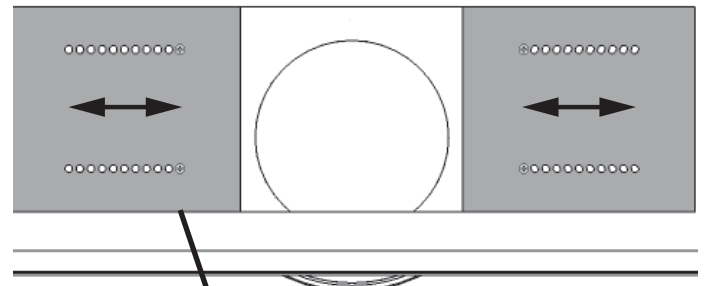

- a) Establish the required position of the restrictors looking up the appropriate venting table (according to vent pipes size) on the previous pages.
 - b) Remove the screws (2) on each restrictor already installed **on the firebox roof port**.
 - c) Slide the restrictors in the required positions.
 - d) Refit and tighten the screws.
5. Reinstall the top panel sliding it on the back screws previously released; tighten the screws.
 6. Refit and tighten the screws at the front of the panel.

VENTING

Horizontal Vent Termination Location

- The vent terminal must be located on an outside wall or through the roof.
- This direct vent appliance is designed to operate when an undisturbed airflow hits the outside vent terminal from any direction.
- The minimum clearances from this terminal that must be maintained when located on an outside wall are shown in figure below. Any reduction in these clearances could result in a disruption of the airflow

or a safety hazard. Local codes or regulations may require greater clearances.

- The vent terminal must not be recessed into a wall or siding.
- The vent terminal should be positioned where any snowdrifts will not cover it.
- Sidewall vent terminations require a terminal guard such as 658TG or 845TG when accessible—within 7' of ground.

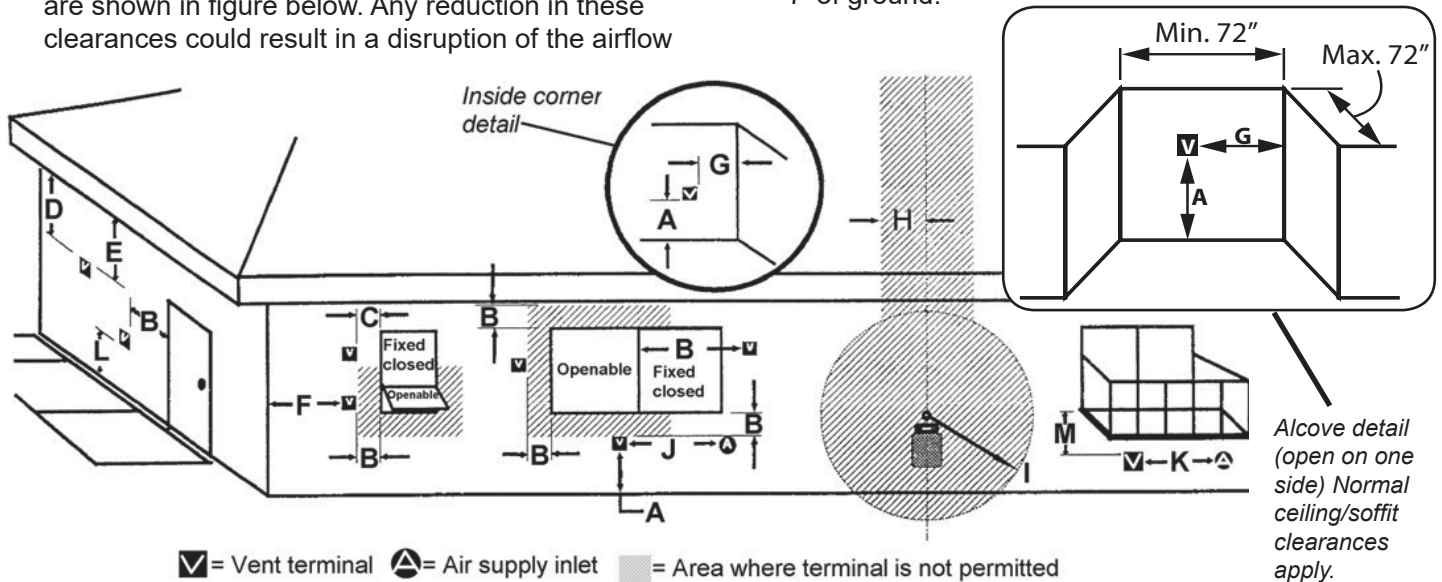

KEY	VENT TERMINAL LOCATIONS - MINIMUM DISTANCES	MINIMUM CLEARANCE	
		Inches	Cm
A	Clearance above grade, verandah, porch, deck or balcony	12	30
B	Clearance to window or door that may be opened	12	30
C	Clearance to permanently closed window (recommended to prevent condensation on window)	12	30
D	Vertical clearance to ventilated soffit located above the terminal within a horizontal distance of 2 feet (60 cm) from the center-line of the terminal	18	46
E	Clearance to unventilated soffit	12	30
F	Clearance to outside corner	12	30
G	Clearance to inside corner	12	30
H	Horizontal clearance to center-line of meter/regulator assembly located within 15 feet (4.6 m) below the terminal	36	90
I	Clearance to service regulator vent outlet	36	90
J	Clearance to non-mechanical air supply inlet to the building or the combustion air inlet to any other appliance	12	30
K	Clearance to a mechanical air supply inlet	72	180
L	Clearance above paved sidewalk or a paved driveway located on public property Note: A vent must not terminate directly above a sidewalk or paved driveway, which is located between two single-family dwellings and serves both dwellings. THIS DOES NOT APPLY to direct vent, non-condensing appliances in the Province of Ontario.	84	210
M	Clearance under a verandah, porch, deck or balcony <i>Only permitted if veranda, porch, deck or balcony is fully open on a minimum of 2 sides beneath the floor</i>	12	30

Note: Local codes and regulations may require different clearances.

VENTING

Vertical Vent Termination

Roof Pitch	Minimum "H" (feet)
Flat to 7/12	1'
Over 7/12 to 8/12	1.5'
Over 8/12 to 9/12	2'
Over 9/12 to 10/12	2.5'
Over 10/12 to 11/12	3.25'
Over 11/12 to 12/12	4'
Over 12/12 to 14/12	5'

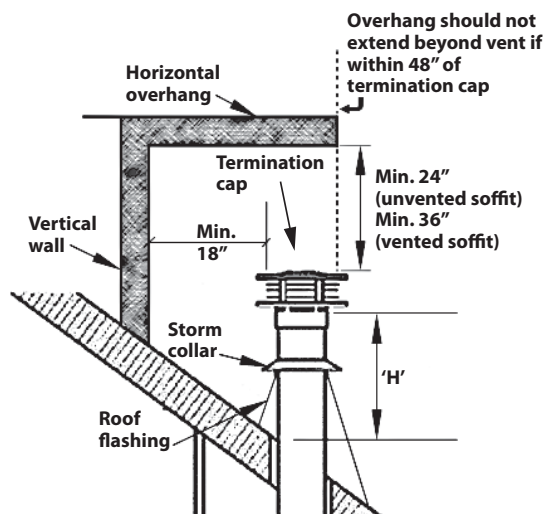

Clearance to air inlet to any other appliance is min. 12" (30 cm)

INSTALLATION PLANNING

Installer—READ THIS FIRST

Only qualified licensed or trained personnel should install this appliance.

1. **YOU NEED TO KNOW FROM THE HOMEOWNER:**
 - The height of the unit and hearth if used;
 - The thickness and type of the wall finish around the appliance;
 - What accessories (shelf, underbed lighting, etc.) will be installed with this fireplace;
 - The venting configuration - 4 x 6-5/8 or 5 x 8
2. Unpack the appliance but keep the barrier screen in its packaging to protect it; recycle the packaging.
3. Remove the bottom plate in front of the window.
4. Remove the window and all items inside the firebox.
5. Check that you have everything, using the Pack Content sheet. Also, check that you have:
 - ◇ a fuel bed (packed separately)
 - ◇ a set of liners (packed separately)
 - ◇ Remote Battery & Wall Switch Kit RBSWK
 - ◇ LDK HeatShift Duct Kit (mandatory)
 - ◇ Gas conversion kit if necessary
 - ◇ Venting accessories
 - ◇ Electrical accessories
 - ◇ 2200ULK—Underbed Lighting Kit (if used)

Please note that the LDK HeatShift Duct Kit MUST be installed on this appliance!

6. Carefully read the Installer's Checklist included with the fireplace for the installation sequence.

Please note that the following steps must be done BEFORE the appliance is placed in its final position in the cavity since the connections are done from the back of the appliance:

- electrical connections
- gas connections
- gas conversion (if needed)
- wiring of the Remote Battery & Wall Switch Kit RBWSK

INSTALLATION PLANNING

Plan Wall Finish

Non-Combustible Materials Specifications

Material which will not ignite and burn. Such materials are those consisting entirely of steel, iron, brick, tile, concrete, slate, glass or plasters, or any combination thereof.

Materials that are reported as passing ASTM E 136, Standard Test Method for Behavior of Materials in a Vertical Tube Furnace at 750 °C shall be considered non-combustible materials.

Combustible Materials Specifications

Materials made of or surfaced with wood, compressed paper, plant fibers, plastics, or other material that can ignite and burn, whether flame proofed or not, or plastered or unplastered shall be considered combustible materials.

Non-combustible cement board

The LX2 fireplace requires a 1/2" (13 mm) thick non-combustible cement board to be used as a wall surface immediately above the unit opening in the front and above and behind the opening on each side.

Extending the cement board well beyond the minimum will help avoid cracking due to differential expansion of materials.

Pre-drill cement board with oversized holes and do not over-tighten screws to avoid cracking due to heat expansion.

Standard gypsum wall board may be used beyond the perimeter of the cement board.

Non-combustible finishing over cement board

Additional non-combustible material such as tile, etc., may be applied over top of the cement board or you may choose to leave it finished clean with no tile.

Cracking wall finishes

The LDK HeatShift Duct Kit reduces the wall temperatures and minimizes the possibility of cracking wall finishes.

If a clean finish with no tile, etc. is desired, joints in the cement board and the transition to gypsum board will require special attention if future cracking is to be controlled. Be aware that temperatures on the non-combustible wall surface above the appliance can exceed 175°F.

Below are some tips on how to best avoid any cracking:

- Allow materials to dry thoroughly before finishing the wall. Cement board has the ability to absorb up to 30 percent of its weight in water and may shrink as much as 1/8" over a 48" length when drying from a saturated condition. Running the fireplace before final finishing will help drive out moisture.
- Always pre-drill screw holes through cement board and use screws with self-milling head.
- Always use tape over joints.
- Behind joints, double up studs or use studs "on the flat" to add extra support to the joint. Adhesive on the backside of wall board behind any joints can help control differential movement.
- Use multiple, thinner coats of joint compound and allow to dry thoroughly between coats.
- Ensure framing materials are dry.
- After finishing the wall, introduce heat gradually to slowly dry any excess moisture rather than drying too fast.
- Avoid notching cement board or tiles around corners of window opening and instead provide a joint that intersects the corner.

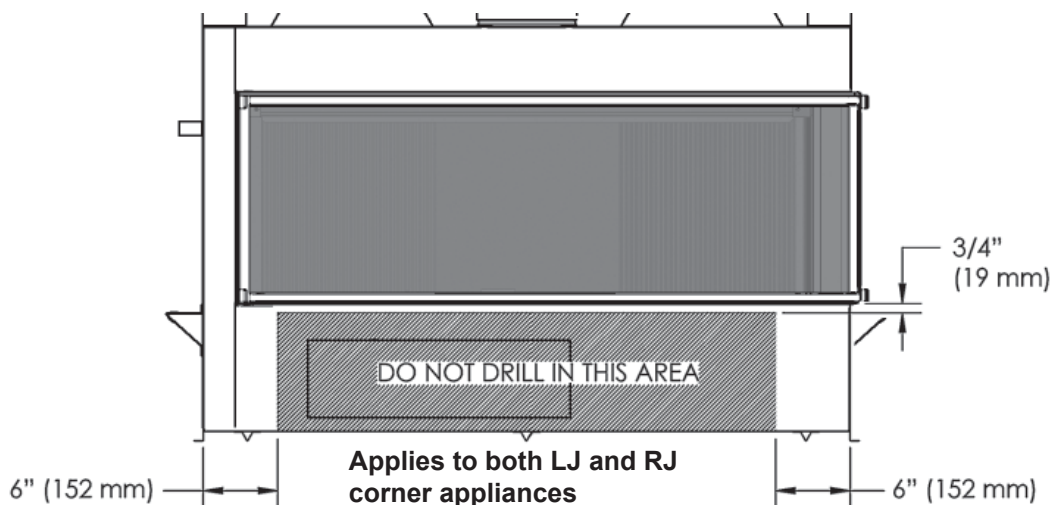

Please note that the LDK HeatShift Duct Kit MUST be installed on this appliance!

Unpack Appliance

Beware of sharp edges! Wear gloves!

1. Remove the wood pallet and packaging from the appliance and discard. Keep the barrier screen in its carton to avoid damaging it.
2. Unpack any loose items around the appliance.
3. **Verify that you have all the components required for the installation, including:**
 - *approved non combustible cement board;*
 - *liners and fuel bed (in separate cartons);*
 - *barrier screen;*
 - *venting components and accessories;*
 - *LDK HeatShift Duct Kit components;*
 - *electrical components.*

Remove Base Plate and Window

1. Remove the base plate. From the fireplace's open corner,
 - a) slide the plate sideways;
 - b) lift the plate up.

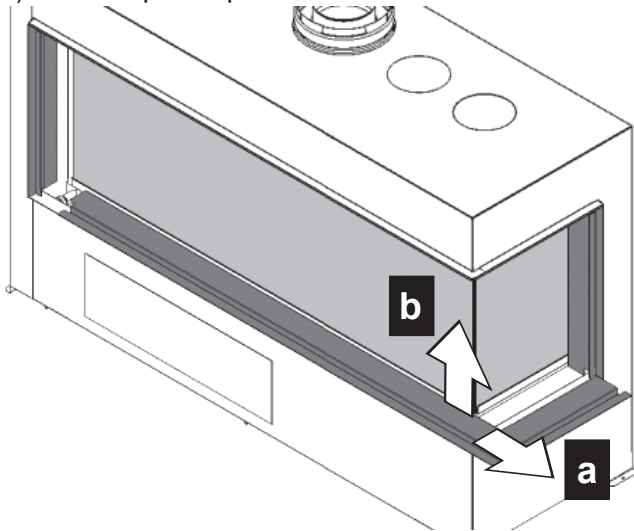

2. The window is held in place by two spring-loaded levers on the top. Hook the window handle to one of the spring-loaded window levers.

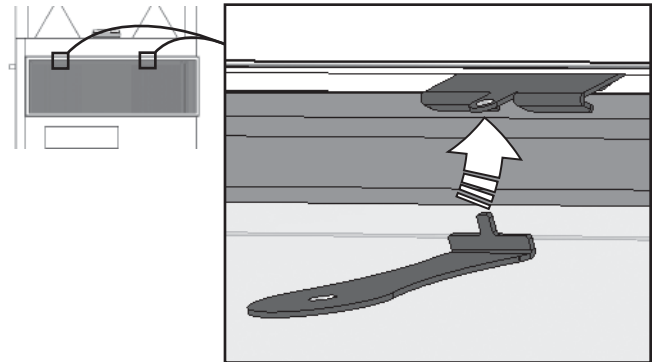

3. Pull the lever and unhook the window. Repeat with the other lever.

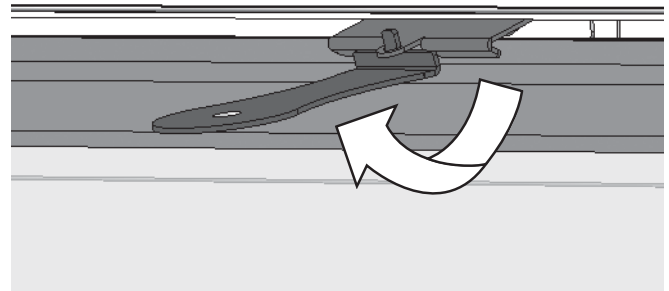

4. Pull the top of the window outward and lift it up behind the front panel to disengage it from its rail.

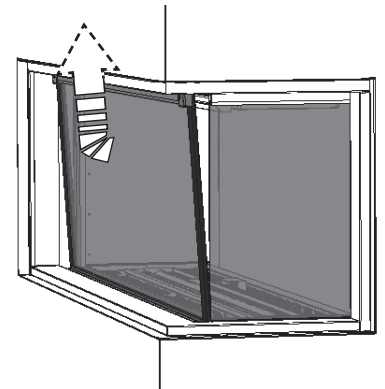

5. Once removed from the bottom rail, rotate the window pane outward to take it out completely; set it aside in a safe place to avoid damage.

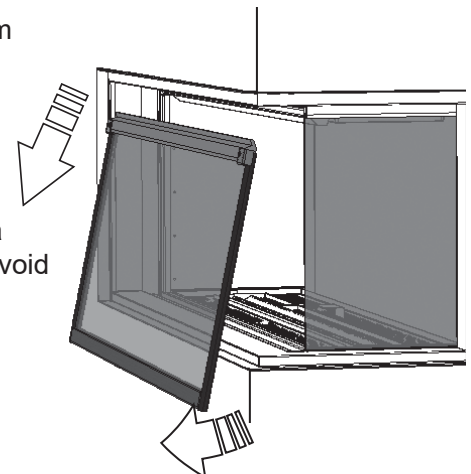

INSTALLATION

Install Standoffs

The standoffs are supplied flat. Bend them as shown and fix them to the top of the firebox.

Note: If installing with an all steel framing, the top standoffs are not necessary. Ensure that the framing is self-supporting, that is it NOT supported by the engine.

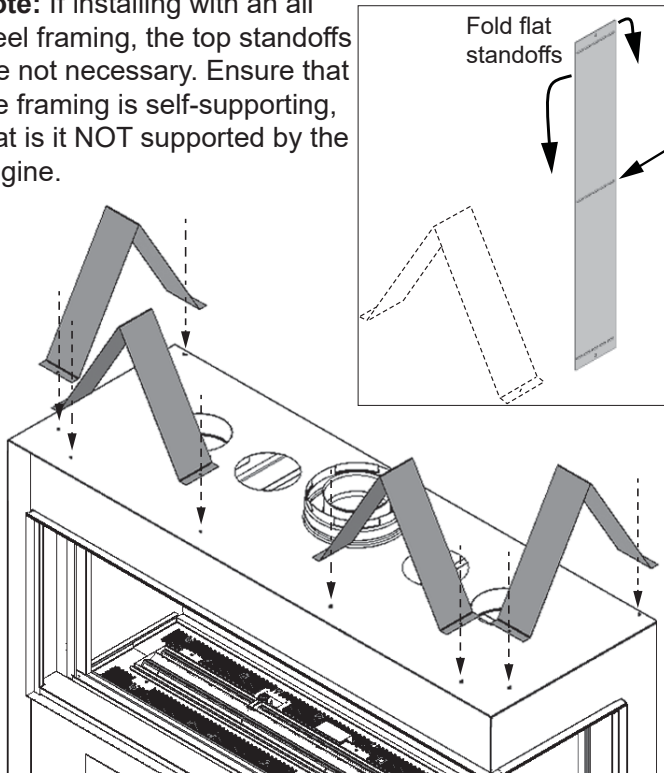

Install 6-5/8" x 4" Vent Adapter (if required)

This unit is supplied with a 5" x 8" vent outlet which can be field-converted to a 4" x 6-5/8" vent outlet by installing the vent adapter supplied with the appliance.

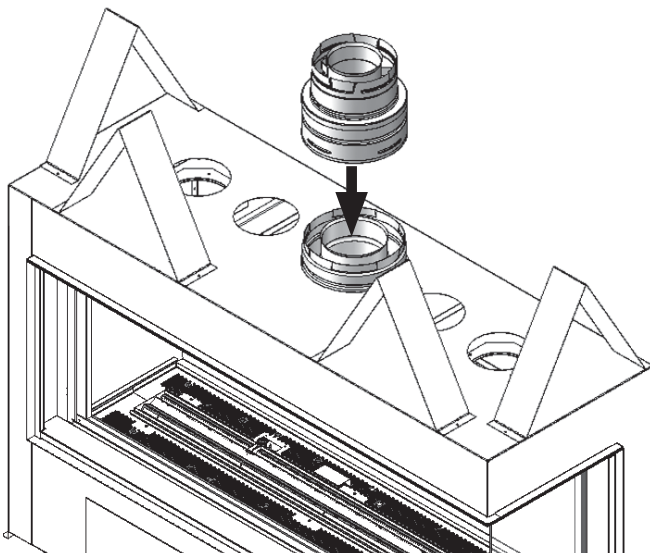

Install HeatShift Take-off Collars (required)

Install HeatShift take-off collars to appliance using screws provided with appliance. See installation instructions packed with the HeatShift kits for details.

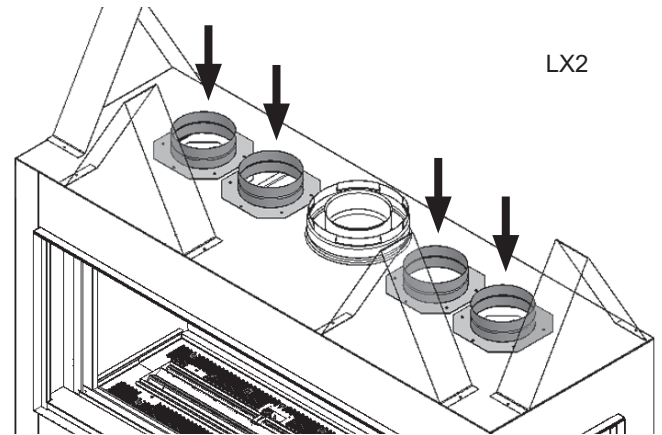

Prepare Appliance for Wiring

Decorative Lighting and Remote Battery & Wall Switch Kit (RBWSK)

The fireplace **must be connected to the electrical system of the home PRIOR to the final positioning of the fireplace** into the framing. The decorative lighting above the firebed is operated by the fireplace's remote control handset.

Wiring for the overhead lighting and RBWSK kit is accessible from the rear panel of the appliance and therefore it should be done BEFORE the final positioning of the fireplace in the framing.

Optional 2200ULK—Underbed Lighting Kit

Additionally, the 2200ULK—Underbed Lighting Kit is offered as an option (sold separately) to provide decorative light under the fuel bed. This kit **is optional and if used, the wiring is also accessible from the rear of the appliance and therefore, it must be installed BEFORE the final positioning** of the fireplace into the framing. It is operated by a dimmer switch (not supplied) installed outside the fireplace. Use the instructions provided with the kit for the installation.

All electrical installations must be performed by a qualified electrician and must be electrically wired and grounded in accordance with local codes, or, in the absence of local codes, with the *National Electrical Code, ANSI/NFPA 70* or the *Canadian Electrical Code, CSA C22.1*.

The fireplace's upper decorative lighting is connected to the v-module box located behind the appliance's front panel below the window. It is hidden under the valve shield. The v-module is powered by a three-prong plug plugged into a receptacle inside the appliance case, at the rear, on the left-hand side.

1. At the back of the fireplace case, on the left-hand side, remove the electrical box cover (4 screws).

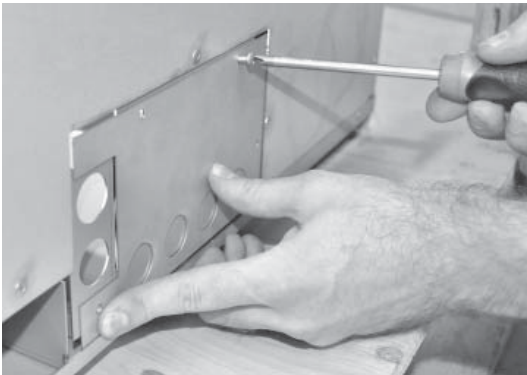
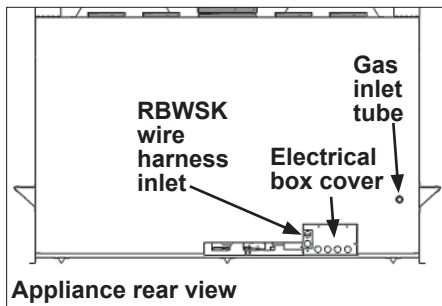

2. Remove the knock-out covers according to the number of electrical connections needed (1 for incoming power, 1 for optional 2200ULK—Underbed Lighting Kit's dimmer switch).

3. Rough in the wiring harness for the **RBWSK—Remote Battery & Wall Switch Kit**. Thread through one of the holes to the left of the electrical panel both the power connector and the white connector end of the wire harness to reach the receiver at the front of the appliance, about 3 feet (36 cm).

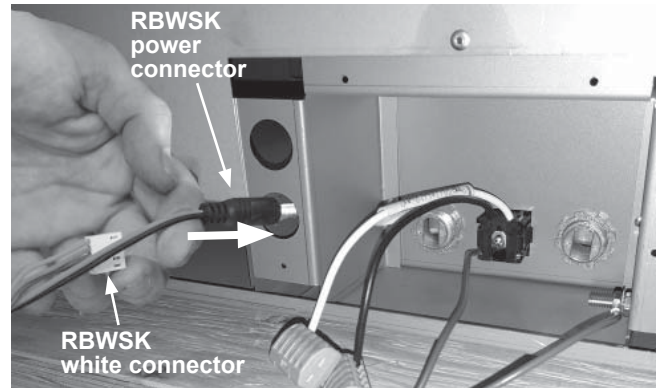

4. **If installing the optional 2200ULK—Underbed Lighting Kit, do it now** so you can connect it to the electrical wiring while the appliance is not in final position. Follow instructions provided with the ULK kit for installation into the firebox.
5. Refit the electrical box cover.
6. Remove the 4 screws retaining the appliance to its pallet. Snap off the feet attached to the pallet and discard or recycle.
7. With great care not to cut yourself on the sharp feet, set the appliance **partially** into the framing keeping in mind the need to access the rear of the appliance to connect the electrical wires.

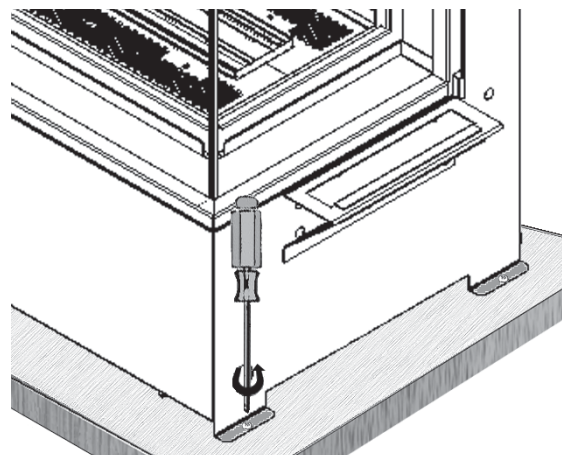

INSTALLATION

Set-up Gas Supply

The gas supply inlet connection is a 1/2" NPT male line stub located on the rear left hand side of the appliance (same location for LJ and RJ appliances).

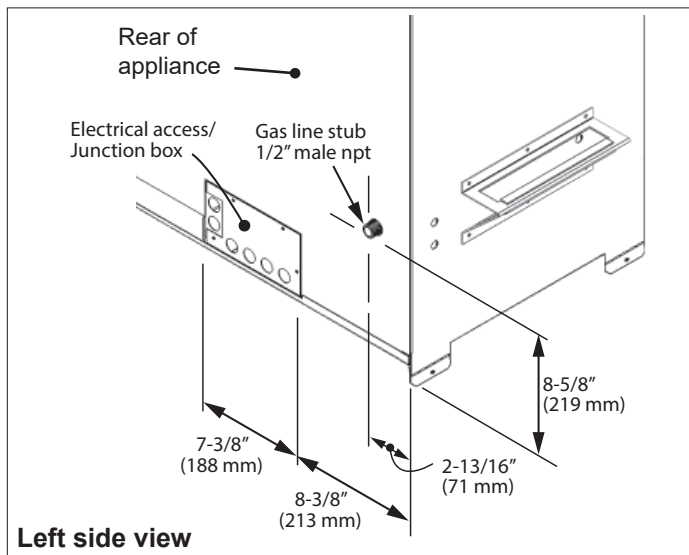
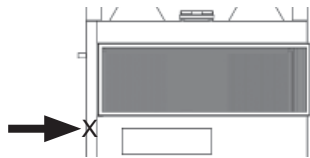

Use only new black iron or steel pipes or copper tubing if acceptable—check local codes. Note that in USA, copper tubing must be internally tinned for protection against sulfur compounds.

Unions in gas lines should be of ground joint type.

The gas supply line must be sized and installed to provide a supply of gas sufficient to meet the maximum demand of the appliance without undue loss of pressure.

Sealant used must be resistant to the action of all gas constituents including LP gas. Sealant should be applied lightly to male threads to ensure excess sealant does not enter gas lines.

Pressure test the supply line for leaks.

The appliance and its individual shut-off valve must be disconnected from the gas supply piping system during any pressure testing of that system at test pressures in excess of 1/2 psig (3.5 kPa).

The appliance must be isolated from the gas supply piping system by closing its individual manual shut-off valve during any pressure testing of the gas supply piping system at test pressures equal to or less than 1/2 psig (3.5 kPa).

Failure to either disconnect or isolate the appliance during pressure testing may result in regulator or valve damages and void the warranty. Consult your dealer in case of damages.

Pressure Test Points

The minimum supply pressure is given in the section *Specifications* of this manual—page 24.

All piping and connections must be tested for leaks after installation or servicing. All leaks must be corrected immediately.

When testing for leaks:

- Make sure that the appliance is turned off.
- Open the manual shut-off valve.
- Test for leaks by applying a liquid detergent or soap solution to all joints. Bubbles forming indicate a gas leak.

**Never use an open flame to check for leaks.
Correct any leak detected immediately.**

The pressure test tapping locations are shown in the figure below. An internal regulator within the valve controls the burner manifold pressure. The correct pressure range is shown in the table in section *Specifications* of this manual on page 24. The pressure check should be made with the burner alight and at its highest setting. See *Lighting Instructions* section for full operating details on page 16.

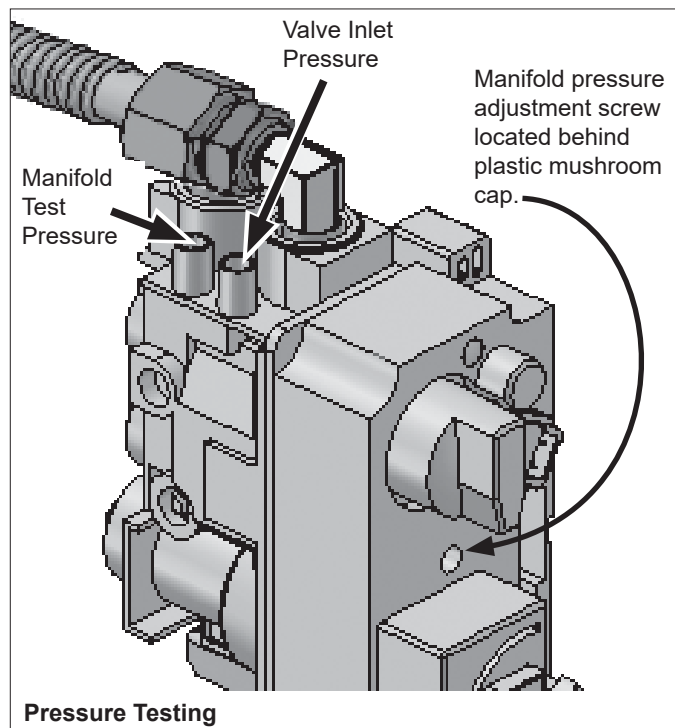

Place Appliance in Final Position

1. Taking great care not to cut your hands on the sheet metal edges, place the appliance in its final position in the framing. *Make sure that the unit is at the right height with consideration to the height of the hearth or combustible flooring.*
2. Remove carrying handles on both side.

Complete Installation of HeatShift Kit (required)

See installation instructions packed with the HeatShift kits for details.

INSTALLATION

Install Liners

Ceramic Liners: The ceramic liner panels consist of three rear sections in one carton and one end panel in a separate carton. The three sections are fitted into each other. Two of the sections are identical. Their step edges go towards the middle to fit into the middle section.

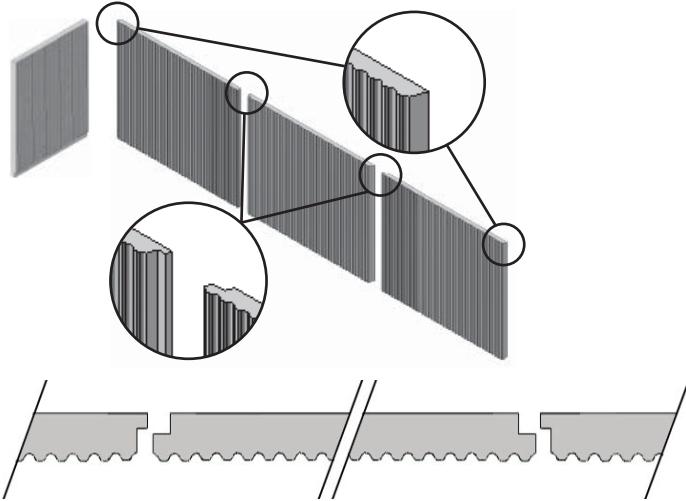

Ceramic liner panel sections—top view

Glass Liners: The glass liner panels consist of three identical rear sections in one carton and one end panel in a separate carton.

The Glass Liners install in the same manner and order as the ceramic panels; however they don't fit into each other. They sit beside each other.

Installation

1. Unpack the liner panels carefully.
2. Remove the rear media tray (3 screws).

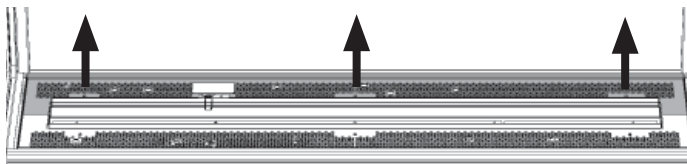

3. Inside the firebox, at the rear of the top panel and on the closed side of the firebox, release the screw of the 4 panel supports and slide the supports towards the middle of the firebox.

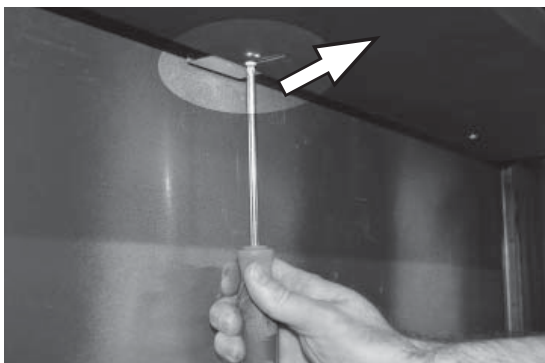

4. Place the end panel, notch at the top, against the side wall of the firebox and rest it on the ledge. Slide the panel towards the front of the firebox.

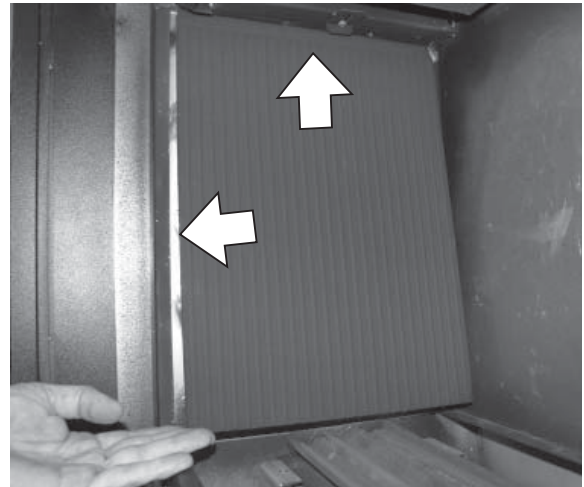

5. Place one rear end panel, top first, against the back wall of the firebox, square edge outward and step edge in the center. Slide the panel outward so it is held behind the mounting support.

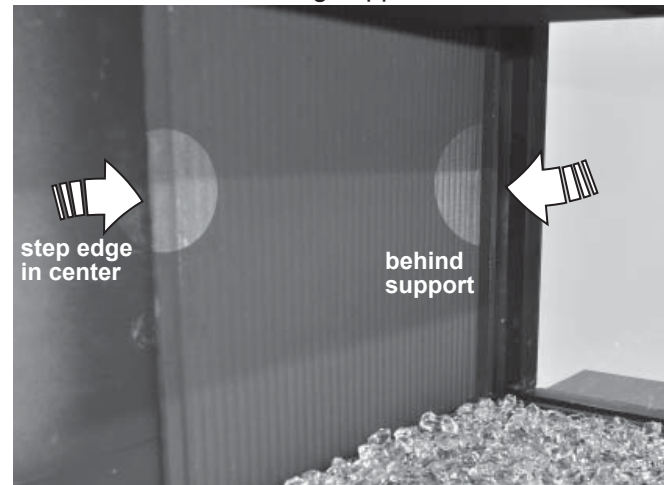

6. Repeat with the other rear end panel.
7. Fit the center panel with its step edges overlapping both end panels.



8. Slide the end panels towards the center and slide the side end panel against the rear panel to eliminate any gaps between them.

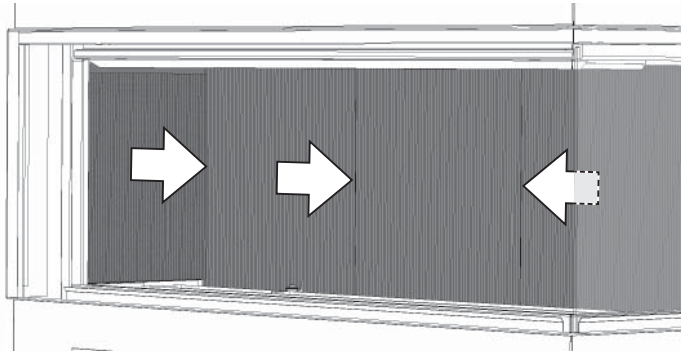

9. Ensure all panels are square against the back wall of the firebox.

10. Push the 4 panel supports against the top of each section and tighten their screw.

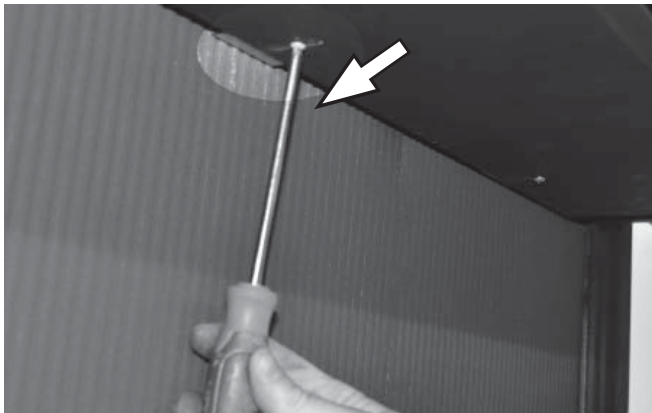

11. Two brick retainers and three glass retainers are supplied with the panels. They are used to hold the bottom of the rear panels against the rear wall of the firebox. The brick retainers have a shallower return and the glass retainers have a deeper return.

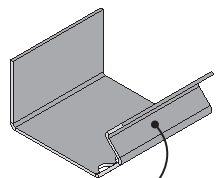

Brick retainer with a shallower return

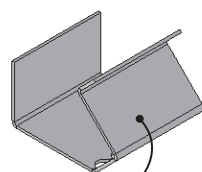

Glass retainer with a deeper return

12. Hook one retainer to the back of the firebox rear wall and fold it over the lip on which sits the ceramic panel so it holds the panel against the rear wall.

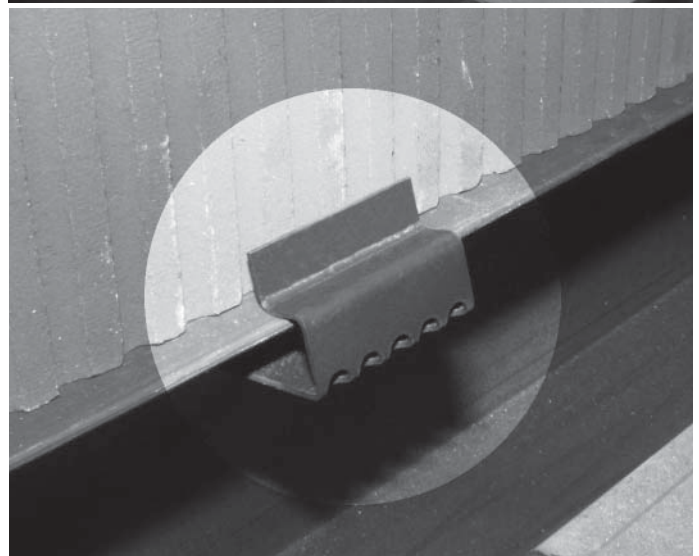
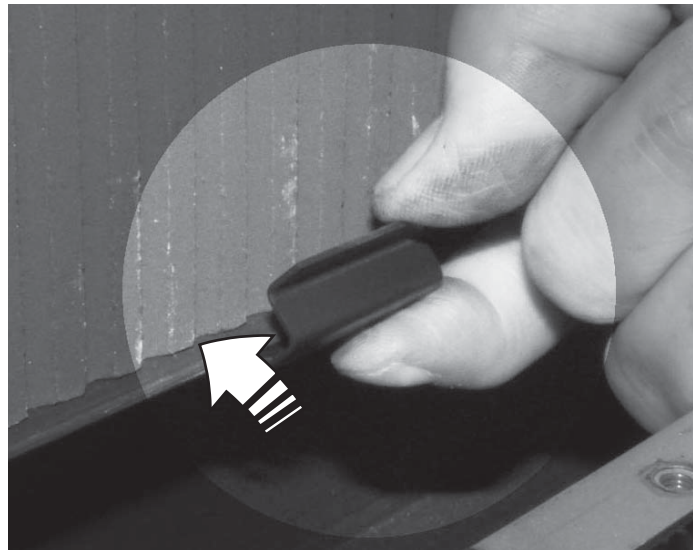

13. Repeat with the other panels.

14. Re-install the rear media tray (3 screws).

INSTALLATION

Install Long Beach Driftwood 1705DWK

Material required

- Small container to distribute vermiculite (not supplied)
- Long Beach Driftwood Kit, which contains:
 - ◇ 6 logs
 - ◇ 10 pebbles
 - ◇ 1 bag of vermiculite

Installation

Vermiculite

Carefully unpack the kit.

1. Carefully spread vermiculite by hand, on the surface of burner only, forming a single layer to the approximate level of the top of the flange at the edge of the burner. **Do not pour from the bag to avoid fine particles blocking the burner ports. Do not use the entire bag.**



NOTE: Ensure the area within the pilot shield is clear of vermiculite. Some vermiculite can be deposited into the pilot safe zone.

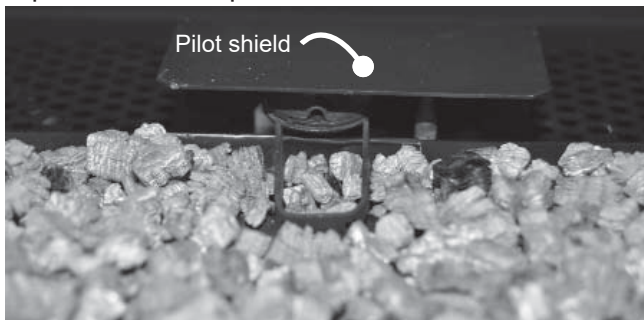

Logs and rocks

Each log has pegs to help you locate it on the media tray. Install the logs as shown below using the **round holes**.

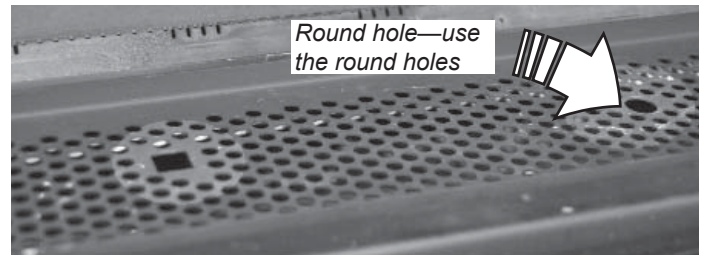

1. Place the rear left log at the left end of the media tray as indicated. Its narrow end rests on the vermiculite as indicated.

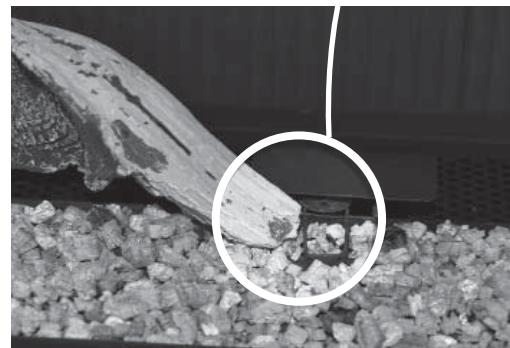
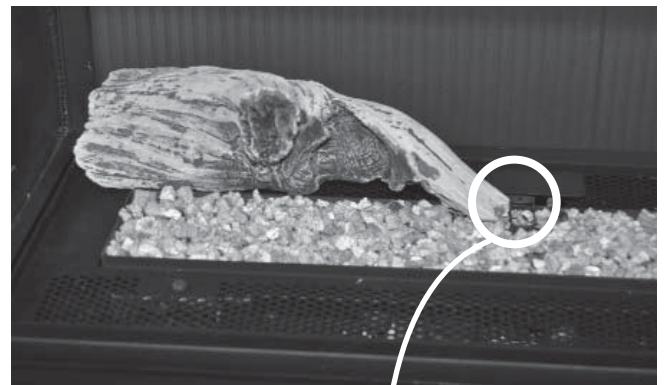
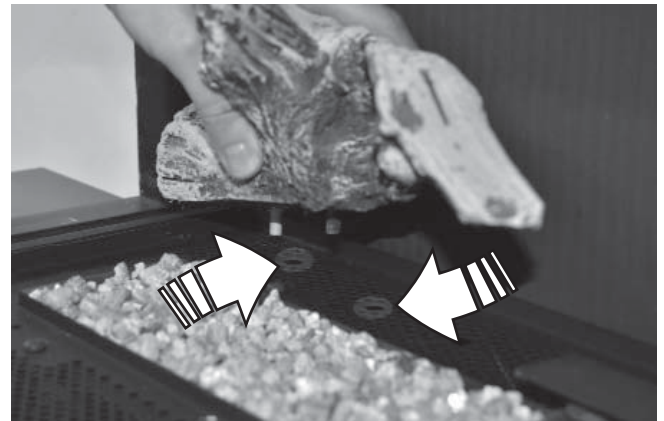

2. Place the front left log as indicated.



3. Place the center rear log as indicated.

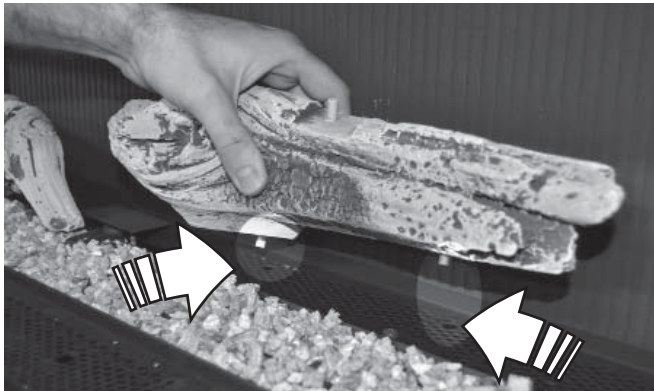

4. Add some vermiculite in the media tray at the right end of the burner and behind as indicated. This vermiculite will help keep the right rear log in position.

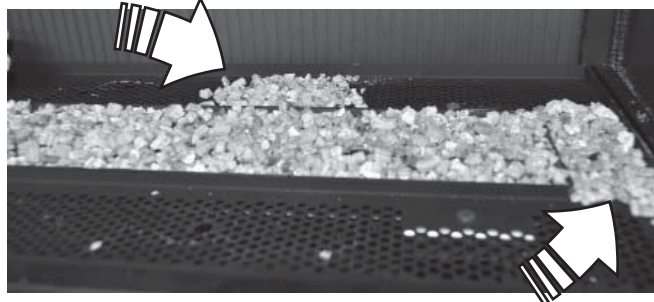

5. Place the right rear log as indicated. The small end of the log rests on the burner, 1-3/4 inch from the front edge of the burner.

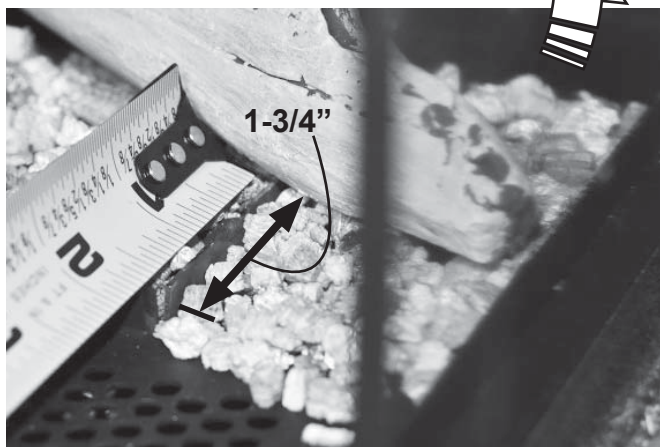
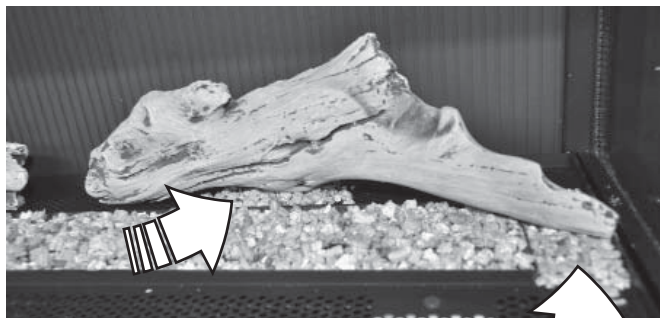

6. Place the right cross log on to recess of right rear log as indicated, ensuring it is firmly located.

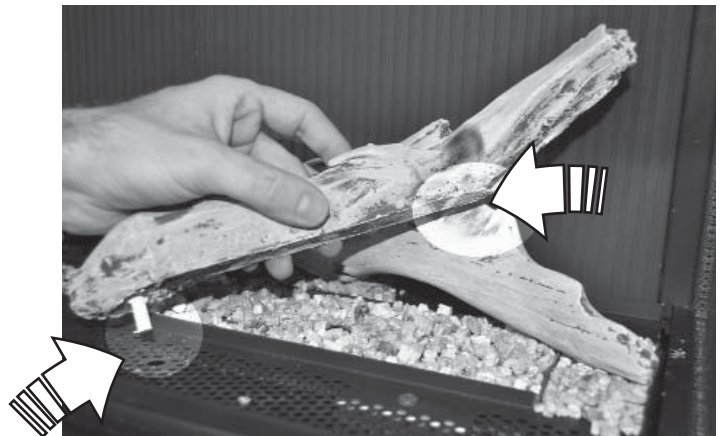

INSTALLATION



7. Lightly rotate forward the center rear log and place the centre cross log onto the rear log as indicated. .

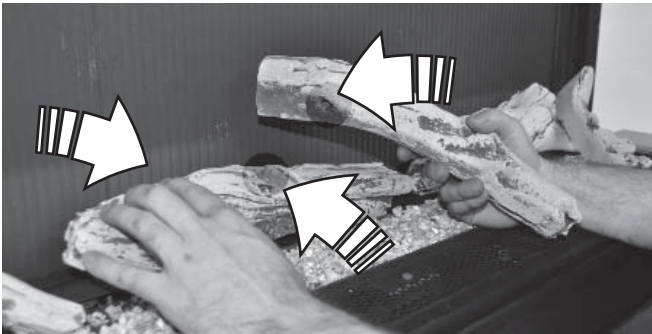

⚠ WARNING
CHOKING HAZARD! Ensure that the fireplace area is clear of vermiculite particles as these could be ingested by small children. Vacuum area after installation.

8. Vermiculite may be added outside the burner on the platform if desired around the logs.



9. Place the rocks on the platform as shown below.



Long Beach Driftwood Kit installed

INSTALLATION

Install Decorative Glass Murano 2200DGM

Material required

- Small container to distribute fire glass (not supplied)
- Decorative Glass Murano kit, which contains:
 - ◊ 1 bag of clear fireglass
 - ◊ 2-piece glass platform
 - ◊ 8 ceramic pads

Installation

Carefully unpack the kit.

1. Install the 8 ceramic pads around the burner as indicated. The pads will raise the glass platform.

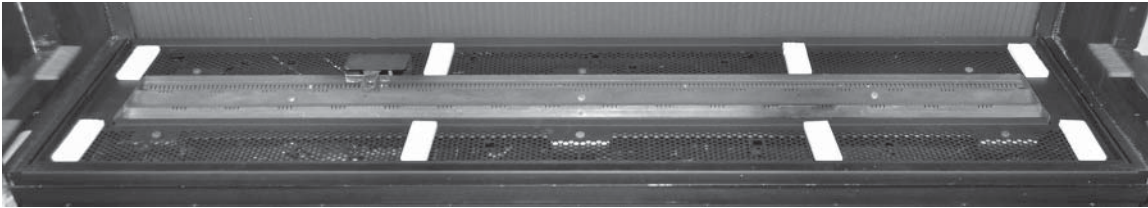

2. Install the front and rear glass platform, smooth side up, on the ceramic pads.

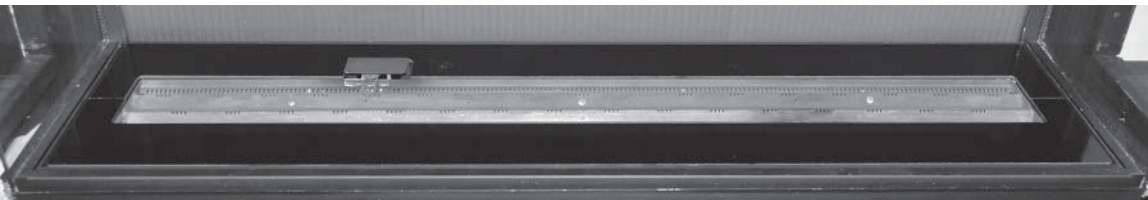

3. Carefully spread the fireglass by hand on the surface of burner forming a single layer to the level of the top edge of the flange around the burner. **Do not pour from the bag to avoid fine particles blocking the burner ports.**

NOTE: Ensure the areas *within* the pilot shield and pilot safe zone are clear of fireglass.

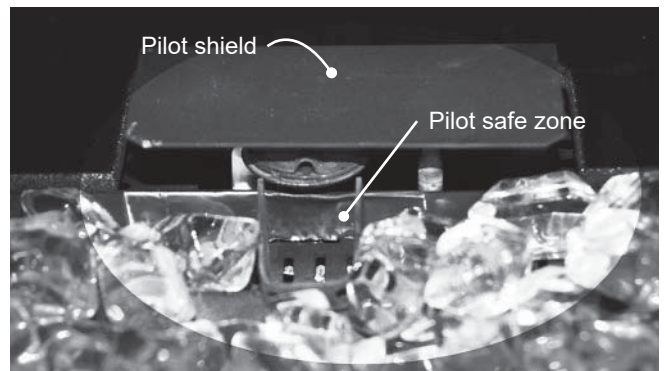

Decorative Glass Murano installed

⚠ WARNING
CHOKING HAZARD! Ensure that the fireplace area is clear of fireglass particles as these could be ingested by small children. Vacuum area after installation.

IMPORTANT: Approved for use only with the fireglass provided with your Valor fireplace. The use of any other fireglass products may void your fireplace warranty.

INSTALLATION

Install Decorative Glass Set 2200DGS

Material required

- Small container to distribute fire glass (not supplied)
- Decorative Glass set, which contains:
 - ◊ 4 bags of clear fireglass

Installation

Carefully unpack the kit.

Carefully spread the fireglass by hand on the surface of burner and the media tray covering the edge of the burner. **Do not pour from the bag to avoid fine particles blocking the burner ports.**

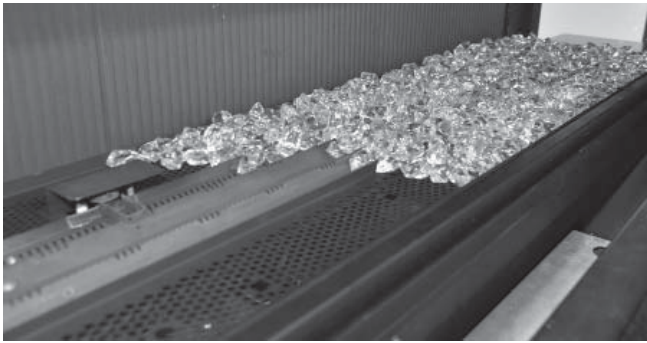

Use one bag of fireglass for the burner, one for the rear media tray and one for the front media tray. Use the fourth bag to fill up gaps or edges of the burner.

WARNING

CHOKING HAZARD! Ensure that the fireplace area is clear of fireglass particles as these could be ingested by small children. Vacuum area after installation.

IMPORTANT: Approved for use only with the fireglass provided with your Valor fireplace. The use of any other fireglass products may void your fireplace warranty.

NOTE: Ensure the areas **within** the pilot shield and pilot safe zone are clear of fireglass.

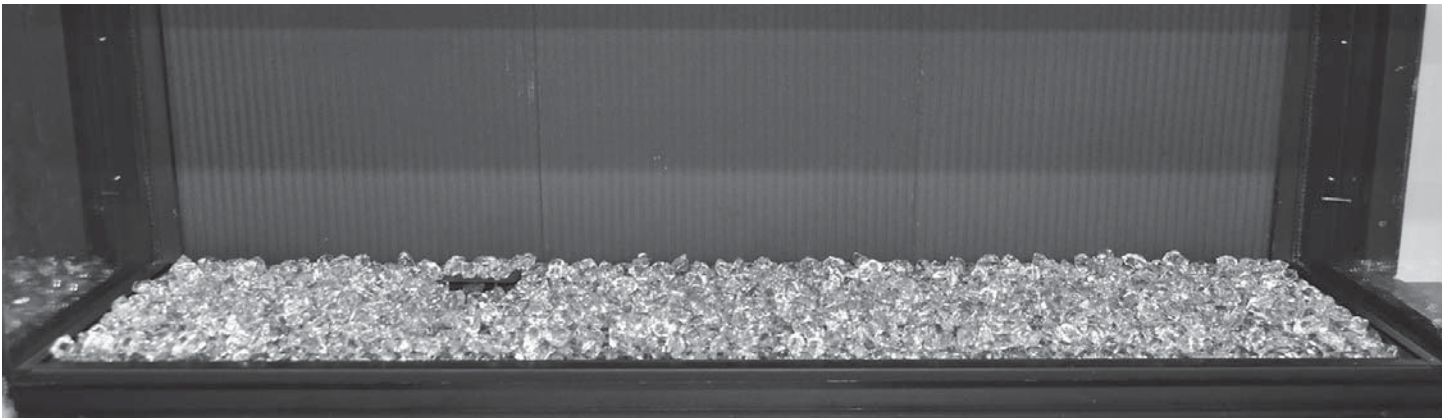
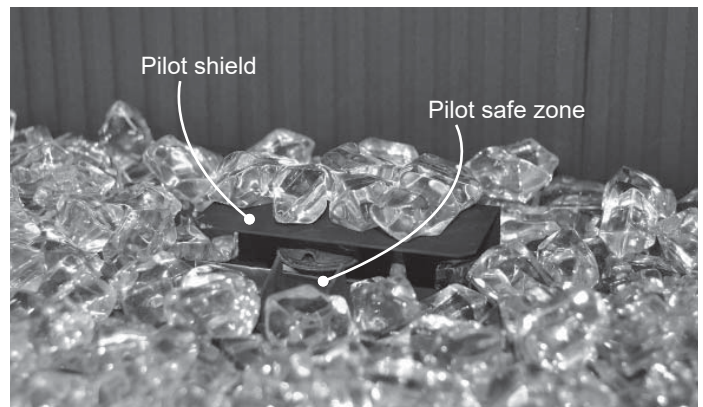

Decorative Glass Set installed

INSTALLATION

Install Splitwood Kit 1700SWK

Material required

- Split Wood Kit, which contains:
 - ◊ 1 bag of splinters
 - ◊ 1 bag of small embers
 - ◊ 11 logs

Installation

Carefully unpack the kit.

Logs, embers & splinters

Some logs are marked with a number to facilitate their identification. They also have positioning pins underneath which fit into the SQUARE holes in the media tray.

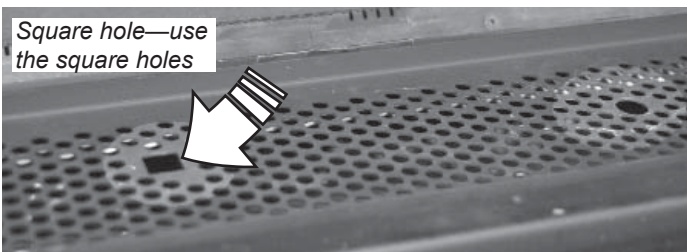

Some logs straddle the burner; make sure they rest over the smaller burner ports rather than the larger ones.

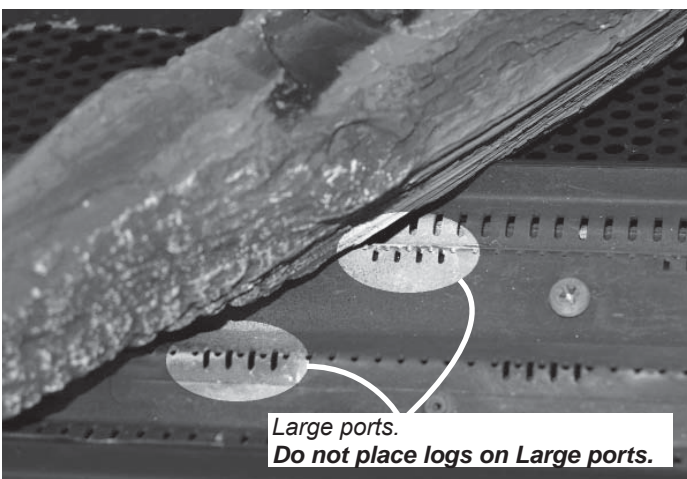

INSTALLATION

1. Install the logs according to the images below. See image of full layout of logs in the following pages. Use the following order: log 1, 2, 3, 4, 6, 5, 7, 9, 8, 10 and 11.

Notes

◇ Log 1 rests on the media tray.

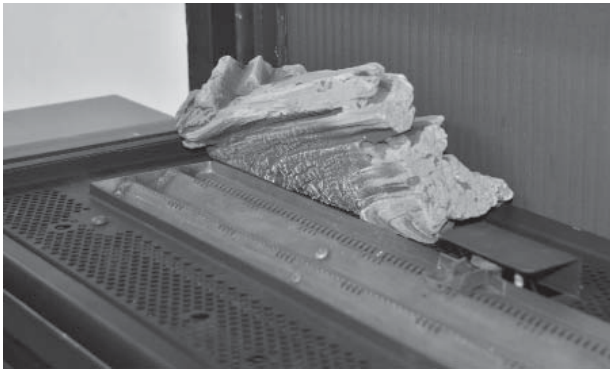

◇ Log 2 rests on notch of log 1.



◇ Log 3 rests across the front corner of the burner.

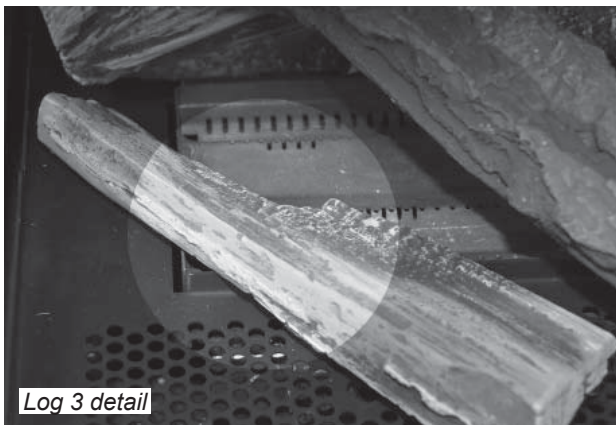

◇ Log 4 straddles the burner, rests on two pieces of ember—do not cover the large burner ports.

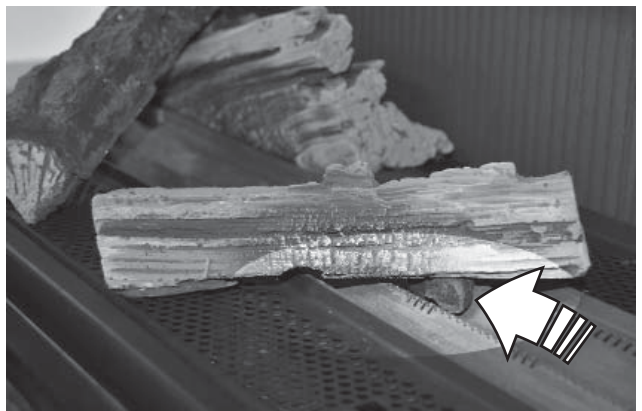

◇ Log 6 straddles the burner—do not cover the large burner ports.

◇ Log 5 rests on rear notch of log 6.

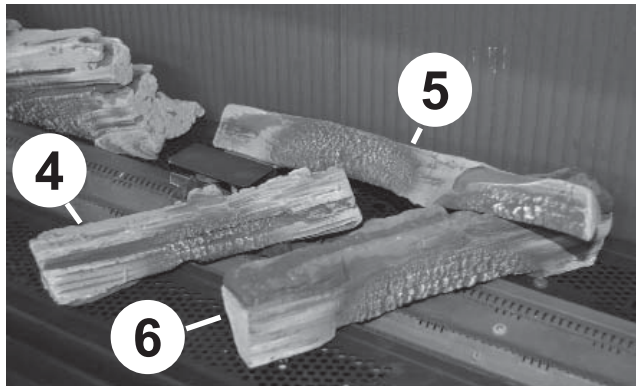

◇ Log 7 rests on front notch of log 6.



INSTALLATION

QUALIFIED
INSTALLER

◇ Log 9 straddles the burner—do not cover the large burner ports.



◇ Log 8 rests on the notch of log 9.

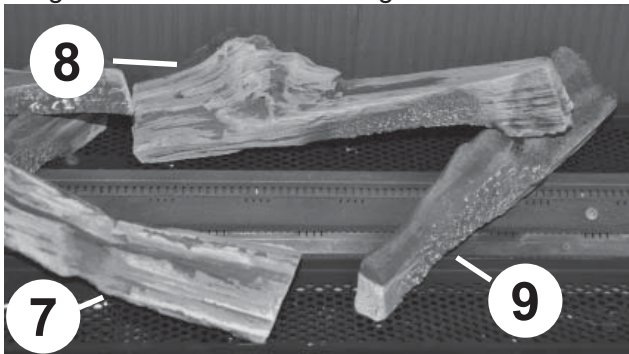

◇ Log 10 rests on the rear and the right edge of the media tray wrapping around the corner of the burner. **Note: the right side of the log does NOT touch the window.**

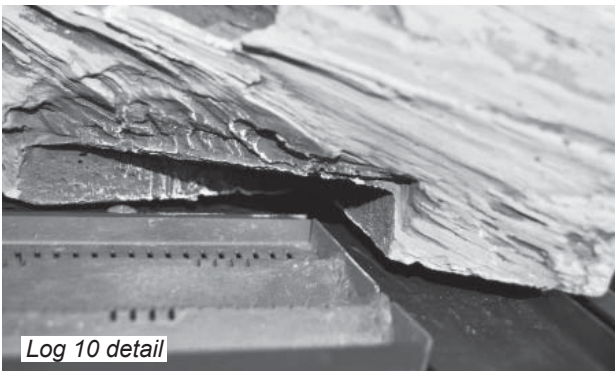

◇ Log 11 rests on notch of log 10.



INSTALLATION

Logs installed—full layout

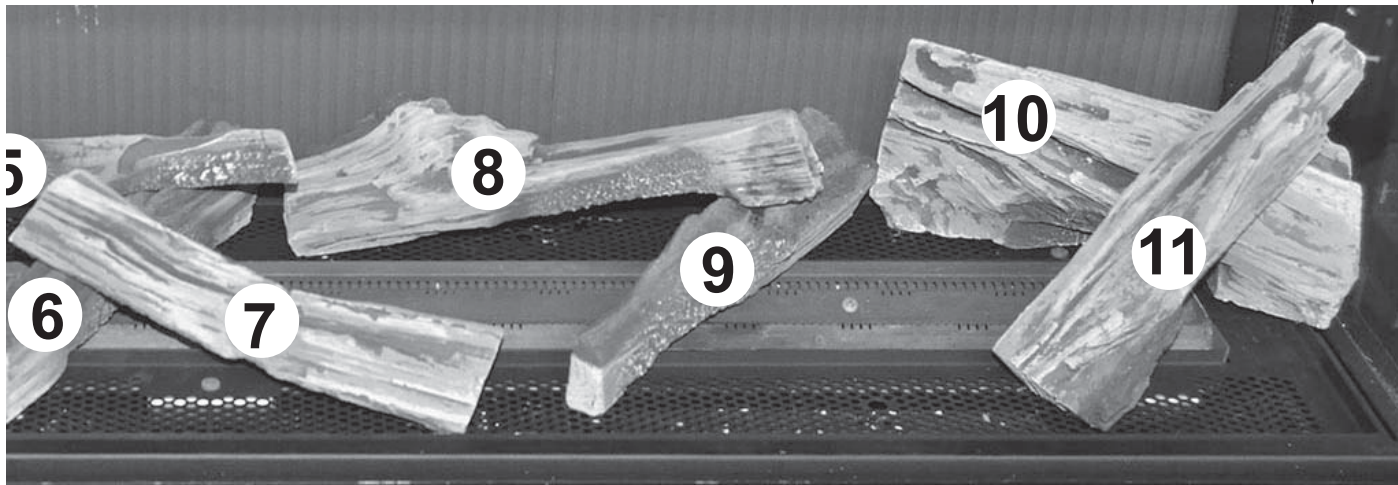
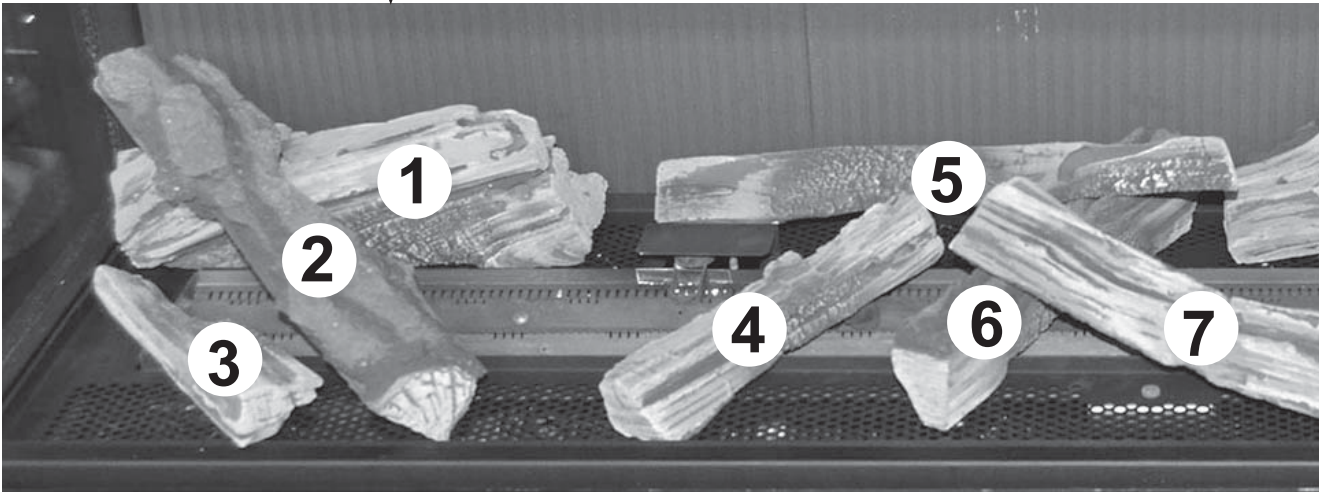
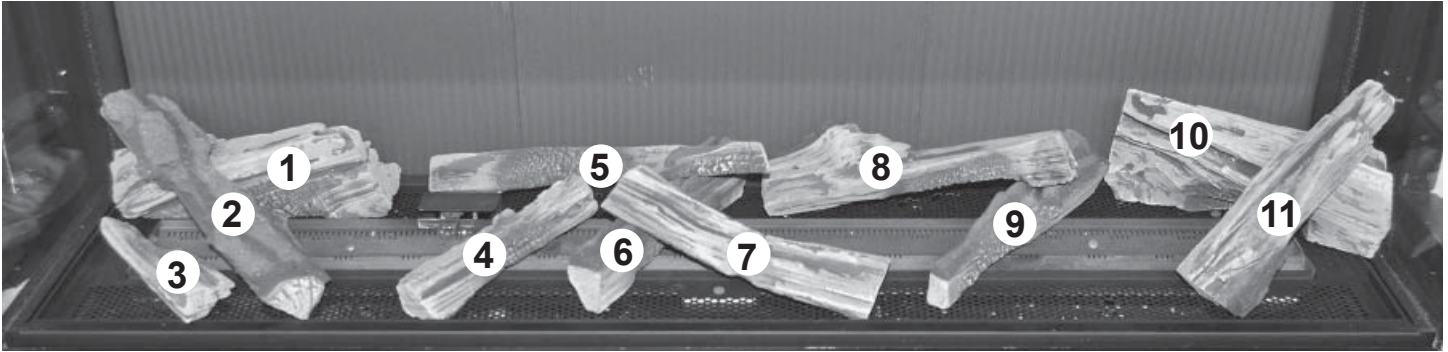

2. Carefully spread the embers by hand, loosely in a single layer on the surface around the logs. **Do not pour from the bag to avoid fine particles blocking the burner ports.**



3. Use the embers to cover the edge of the burner and the round holes.

4. Spread some splinters to the embers.
NOTE: Ensure the areas *within* the pilot shield and pilot safe zone are clear of embers or splinters.

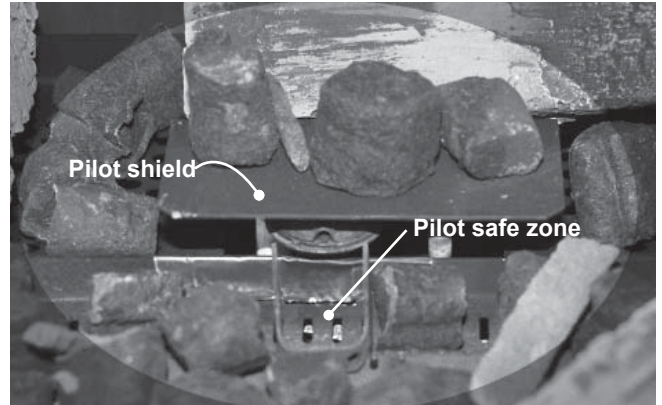

IMPORTANT: Approved for use only with the ceramic embers and splinters provided with your Valor fireplace. The use of any other products may void your fireplace warranty.

⚠ WARNING

CHOKING HAZARD! Ensure that the fireplace area is clear of embers/splinters particles as these could be ingested by small children. Vacuum area after installation.



1700SWK installed

INSTALLATION

Install Rocks & Shale 1714RSS

Material required

- Small container to distribute shale (not supplied)
- Rock & Shale Set, which contains:
 - ◊ 1/2lb-bag of 3/4" grey shale
 - ◊ 1/2lb-bag of 3/4" black shale
 - ◊ 5 twigs
 - ◊ 34 rocks

Installation

Carefully unpack the kit.

1. Mix the black and grey shale pieces and spread them by hand in one layer thick on top of the burner. **Do not pour from the bag to avoid fine particles blocking burner ports. Do not overfill!**



NOTE: Ensure the areas *within* the pilot shield, on the pilot shield and in pilot safe zone are clear of shale. **Do not put rocks on the pilot shield!**

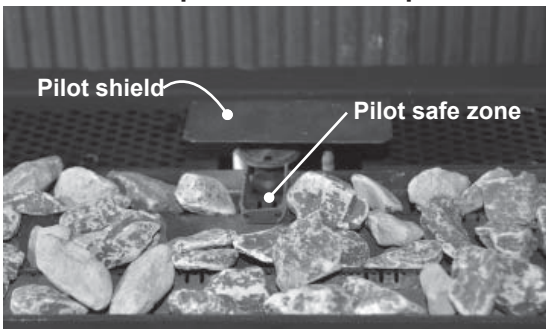

2. Place rocks around the shale bed as indicated. These rocks will be used to support the twigs. The rocks used is not important.

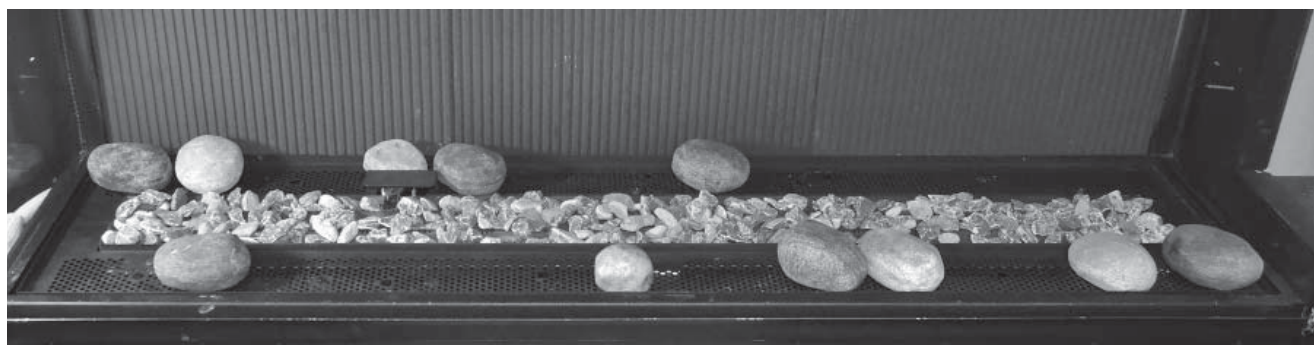

3. Place the twigs on the rocks as shown.

Note: The position of the twigs are specific to obtain the best flame pattern. The twigs should not rest flat on the shale bed. Their position across the shale bed allows some air underneath.

 - a) Place the one of the curvy twigs as indicated.



- b) Place a short Y twig on the rocks behind the pilot shield; rest the other end on the shale bed.



INSTALLATION

c) Place the long Y twig as indicated.



d) Place the other short Y twig as indicated.



e) Place the other curly twig as indicated.



IMPORTANT: Use only the ceramic rocks, twigs and shale provided with your Valor fireplace. The use of any other types of rocks, twigs or shale may void your fireplace warranty.

⚠ WARNING

CHOKING HAZARD! Ensure that the fireplace area is clear of shale pieces as these could be ingested by small children. Vacuum area after installation.

4. Install the remaining rocks around the shale bed. **Do not put any rock on the pilot shield! Do not put rocks on the shale!**

The acceptable variations are only for rocks installed outside of the shale bed.

Suggested positions for additional rocks around shale bed



INSTALLATION

To reinstall the window:

1. Remove any fuel bed media particle from the window bottom rail before installing the window.
2. Ensure the gasket is well fitted to the bottom of the window pane.
3. Insert the window behind the appliance's front panel and lower it into its bottom rail.

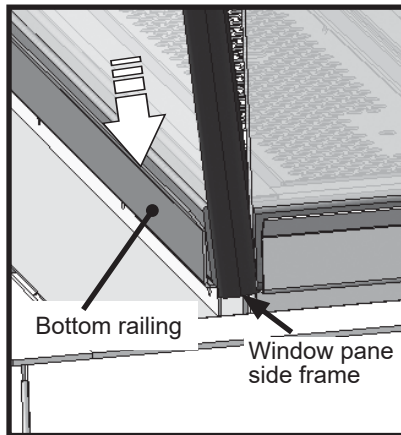
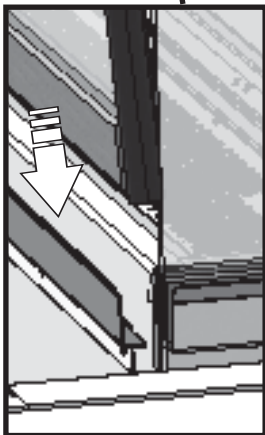
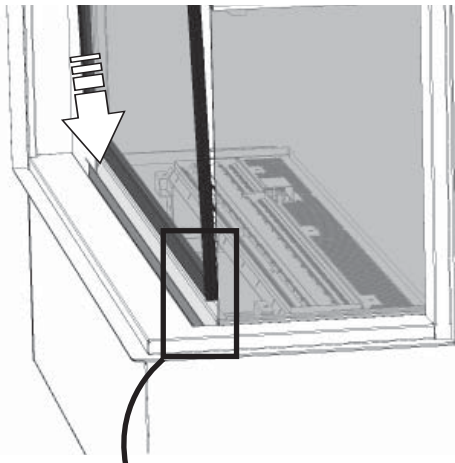
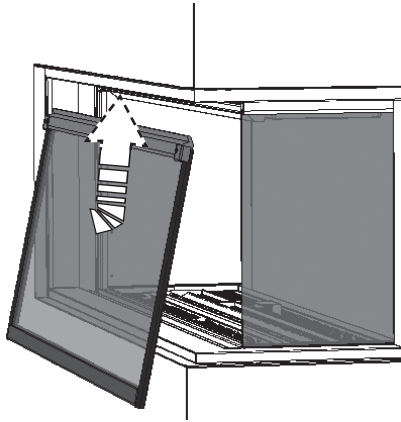

⚠ DANGER

The window unit must be correctly installed, fastened and sealed after servicing or serious bodily injury and/or damage to the appliance may result.

To ensure a safe operation:

- Double-check that the bottom of the window frame is correctly installed in the bottom support railing;
- Verify that the levers are hooked properly to the window tabs then;
- Pull out the top of the window and release it to insure the springs return it;
- Ensure the window is sealed before operation.

⚠ WARNING

Failure to install the window correctly can leak carbon monoxide, affect the performance of the fireplace, damage components, cause overheating resulting in dangerous conditions. Damage caused by incorrect window installation is not covered by the Valor warranty.

4. Push the top of the window pane against the firebox. **Ensure it is centered on the firebox so it seals properly.**
5. While you hold it, pull down and hook one of the spring-loaded levers onto the window top black frame using the door handle. Repeat with the other lever.

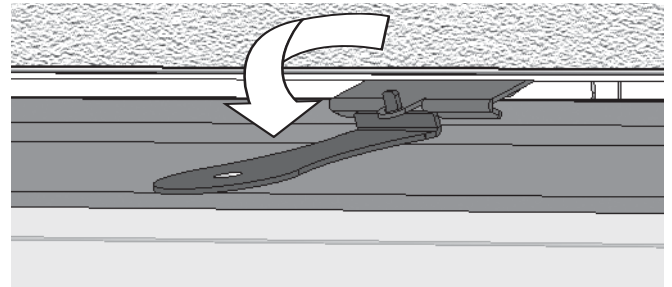

Keep the handle with the manual for the homeowner's use in the future.

INSTALLATION

6. Apply firm hand pressure around the window pane particularly on the top and sides to ensure the window is sealed tight against the firebox.

ENSURE THE FRONT WINDOW'S SILICONE GASKETS ARE WELL SEALED, FROM TOP TO BOTTOM, TO THE SIDE WINDOWS!

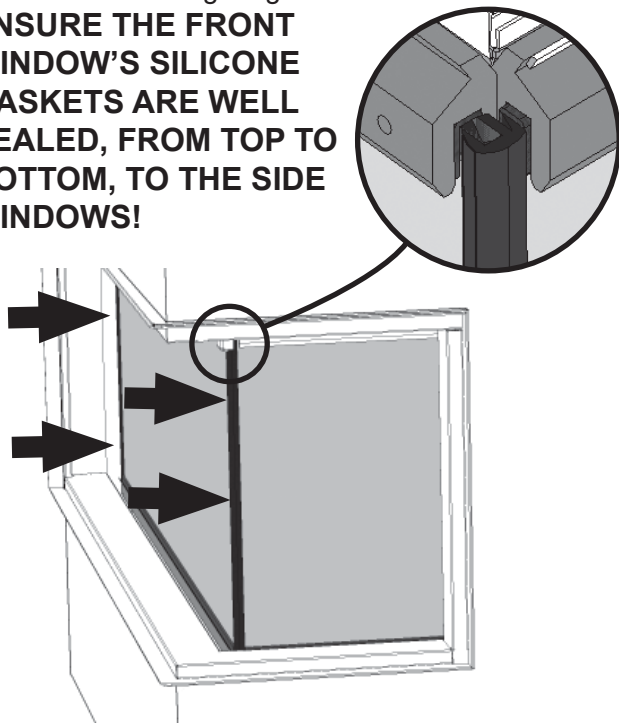

7. If the Hot Glass Warning plate has been removed from the front lower corner of the window, reinstall it by sliding it between the glass and the frame as indicated.

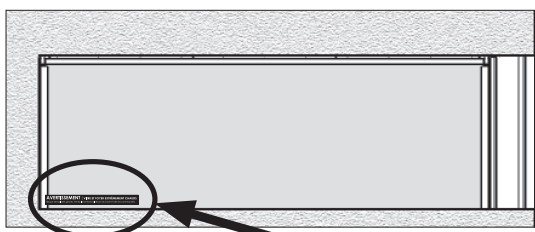

! WARNING: EXTREMELY HOT GLASS AND FIREPLACE
Risk of severe burns. Keep Children away from fireplace & controls.
AVERTISSEMENT : VITRE ET POYER EXTREMEMENT CHAUDS
Risque de brûlures graves. Tenir les enfants à l'écart du foyer et des commandes.

! WARNING: EXTREMELY HOT GLASS AND FIREPLACE
Risk of severe burns. Keep Children away from fireplace & controls.

Hot Glass Warning Plate

INSTALLATION

Install Remote Battery and Wall Switch Kit RBWSK (required)

The Remote Battery and Wall Switch Kit is provided with this appliance. It must be connected to the receiver in the fireplace.

Please note that the batteries cannot be inserted into the receiver inside the appliance. They will overheat and possibly leak and cause the system to stop functioning.

Material required

- 4 AA 1.5V alkaline batteries supplied with the engine
- Remote Battery and Wall Switch Kit, which contains:
 - ◇ 1 Wall Switch
 - ◇ 2 Screws
 - ◇ 1 Battery Holder
 - ◇ 1 Plate with magnets
 - ◇ 1 Battery Cover assembly
 - ◇ 1 Harness assembly - 35 ft
 - ◇ 1 Junction Box
 - ◇ 1 Cover plate and Screws
 - ◇ 1 Cable tie

Installation

The receiver is located behind the appliance's front panel, at the right of the control valve. It is maintained in position with *Velcro* bands.

1. From the front of the appliance through the access panel, grab the wire harness threaded from the back and bring it towards the receiver at the front of the appliance.
2. Pull out the receiver from its location to connect the wiring harness power connector to receiver's jack.



CAUTION

Do not run the switch wire over the top of the firebox. Route the wire so it does not contact the firebox.

3. Connect the harness' white connector to the auxiliary 5-pin junction on the receiver.



4. Run the harness assembly to the mounted position of the junction box, securing the harness to the framing using insulated staples (not supplied).
5. Feed the harness assembly through a restraint on the rear of the junction box, feeding through until the harness sheath is pinched by the retainer and ensuring sufficient length to make the connection to the rear of the switch and battery holder.



6. Secure the junction box to the mounting surface using appropriate fasteners (not supplied).

INSTALLATION

QUALIFIED
INSTALLER

7. Align the molex connection on the switch cable of the harness assembly and connect to switch.

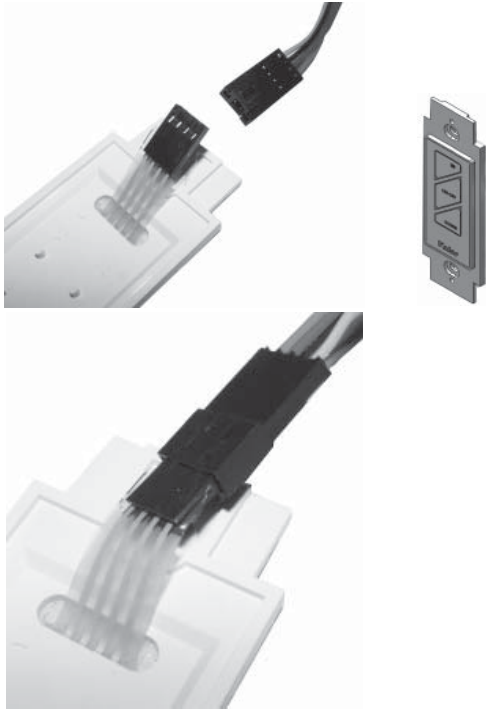

8. Mount the switch plate to the junction box with 2 screws provided. Note: Place the switch left or right to suit the homeowner wishes.

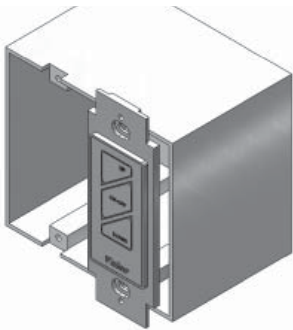

9. Locate and secure the magnet plates using 2 'long' screws provided.

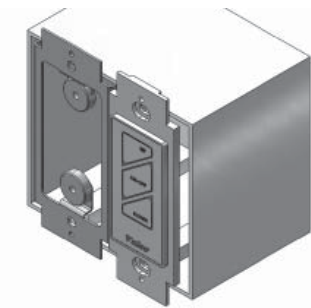

10. Place and secure the cover plate to the box using 4 screws provided.

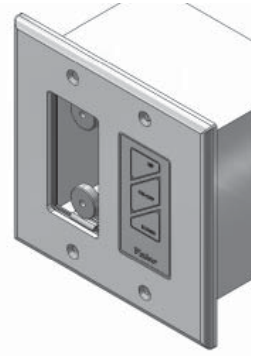

11. Feed the cable tie through the 2 side slots of the battery cover assembly.
12. Position the battery holder to the rear face and secure together with a cable tie. Note that clearance is required for battery snap connection.

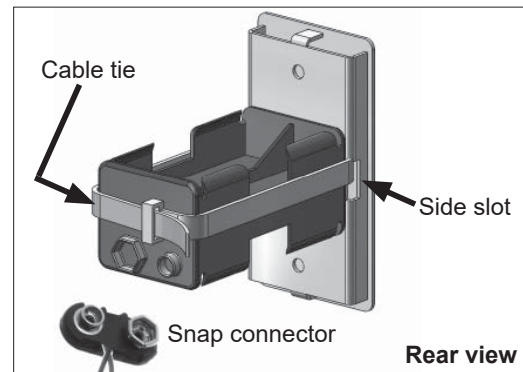

13. Make the snap connection, load 4 AA alkaline batteries into the holder (included with fireplace) then feed back into the junction box assembly.

Note: Do not put batteries in the receiver, only in the battery holder by the wall switch.

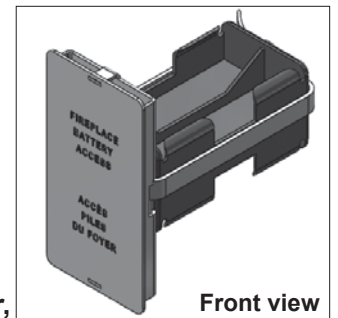

14. Test the operation of the wall switch—see page 15.

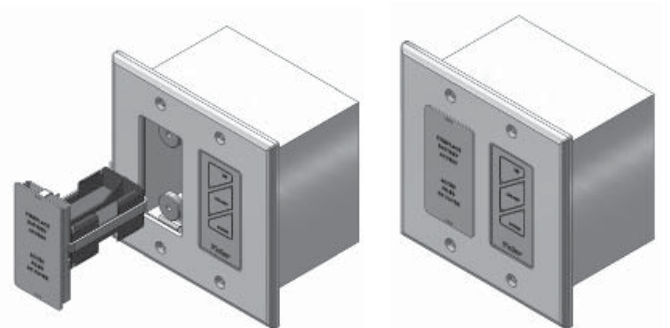

INSTALLATION

Initialize Remote Control

The receiver and the handset of the remote control system must be initially synchronized before the first use. The receiver is located on the bottom of the fireplace behind the front panel under the valve heat shield. The battery holder is located next to the wall switch.

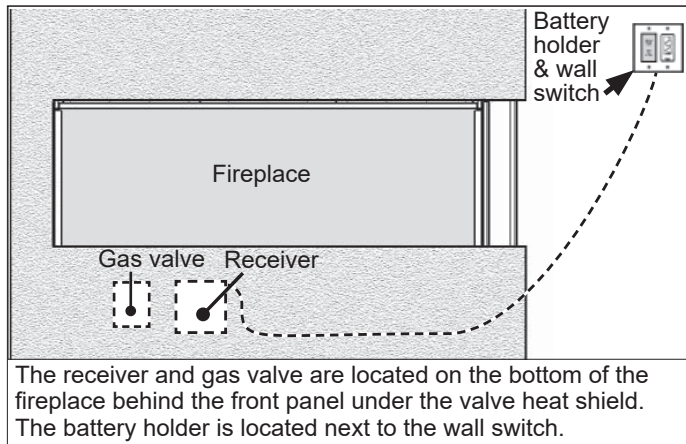

The receiver and gas valve are located on the bottom of the fireplace behind the front panel under the valve heat shield. The battery holder is located next to the wall switch.

1. Insert one 9 V **alkaline** battery in the handset.
2. Behind the front panel of the appliance, slide the valve heat shield to the right and locate the receiver. Detach it from the Velcro and pull it out.

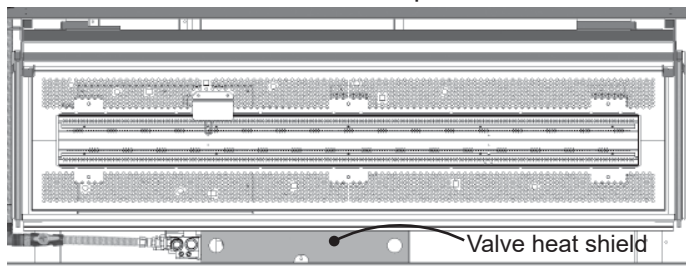

Top view—Valve heat shield closed

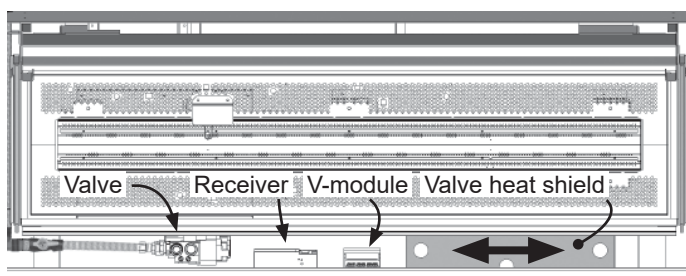

Top view—Slide valve heat shield opened

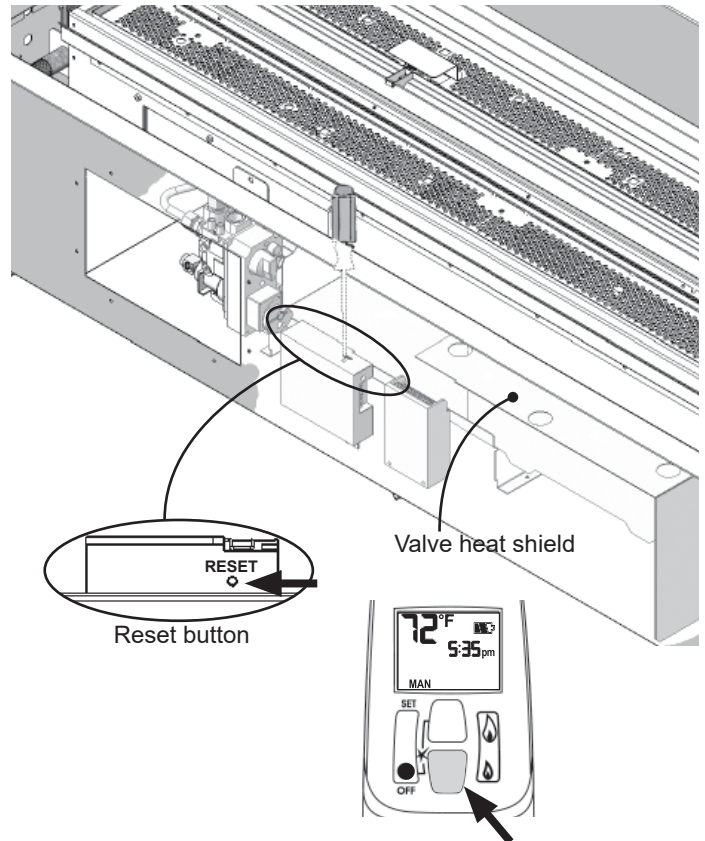

3. Locate the Reset button on the top side of the receiver.
4. With a sharp object, press and hold the receiver's reset button until you hear one short and one long beeps. Release the reset button after the second beep.
5. Within the subsequent 20 seconds, press the (small flame button ()) on the remote handset until you hear two short beeps confirming the synchronization is set. This is a one time setting only and is not required when changing the batteries in the remote battery holder. The remote control system is now ready to use.
6. Put the valve heat shield back in place, over the valve, receiver and v-module.

WARNING

ALWAYS PUT THE VALVE HEAT SHIELD BACK IN PLACE over the valve, receiver and v-module! Otherwise, the controls can overheat and the fireplace stop working.

Check Operation

Turn the fireplace flame up and down using the remote control to confirm that the full range of inputs is achieved—see the remote control operation instructions on pages 9–15.

Set Aeration (if necessary)

Light the fire and allow the unit to warm up for 10–15 minutes to evaluate the flame picture. The burner is equipped with an adjustable shutter to control primary aeration. The shutter is factory-set to an aeration gap which will give optimum performance for the vast majority of installations.

Depending of fuel bed used, altitude and other considerations, the flame picture may be improved by adjusting the aeration. The need for adjustment should be determined only by operating the appliance with the fuel bed, liners and window installed and evaluating the flame picture after a 15-minute warm-up.

Increasing aeration will cause the flames to appear more transparent and blue showing more ceramic effects glow.

Decreasing aeration will cause the flames to appear more yellow or orange showing less ceramic effects glow.

Too little aeration may result in black carbon forming and dropping into the firebox.

To access the air shutter, remove the barrier screen and the base plate. The air shutter lever is located in front of the firebox behind the appliance front panel. Adjust the shutter by using a screwdriver as a lever to slide the shutter left or right.

Air Shutter

(same location for LJ and RJ appliances)

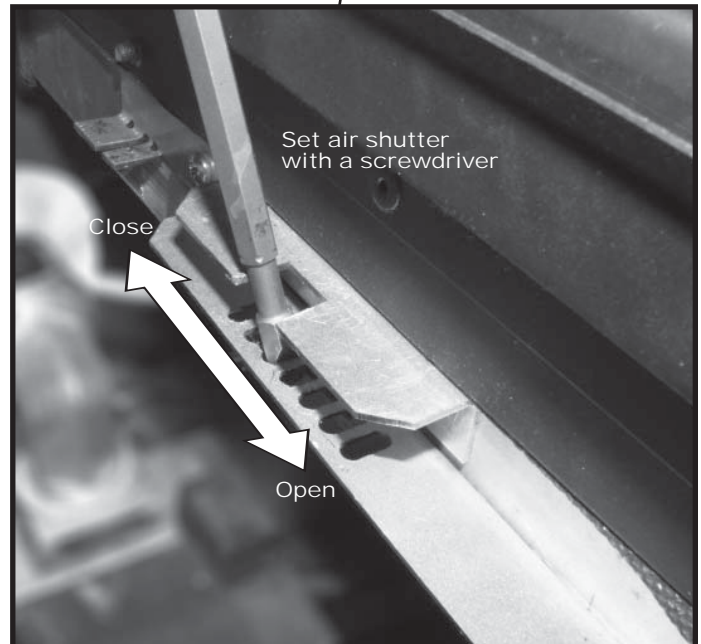
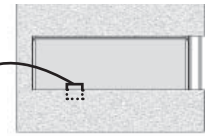

INSTALLATION

Reinstall Base Plate

1. Place the base plate on the fireplace's front flange with the **magnets behind the fireplace's front panel**.

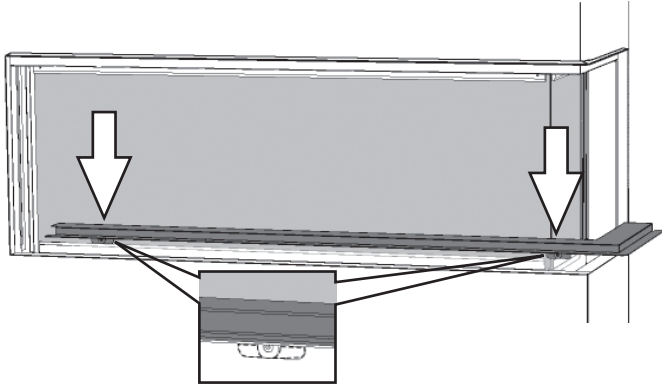

2. Ensuring the plate is lined up with the flange, slide the plate sideways so both its ends butt with the vertical panels of the black frame.

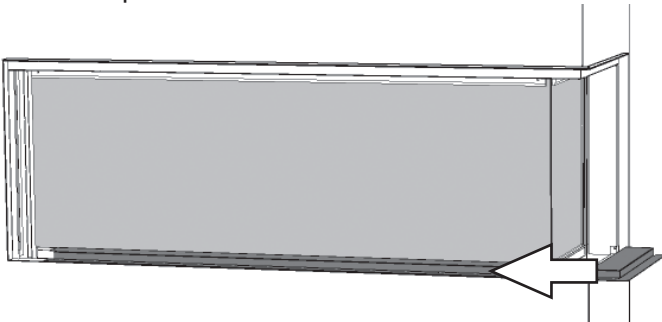

3. Pull the plate forward so it is flush with the fireplace's front flange.

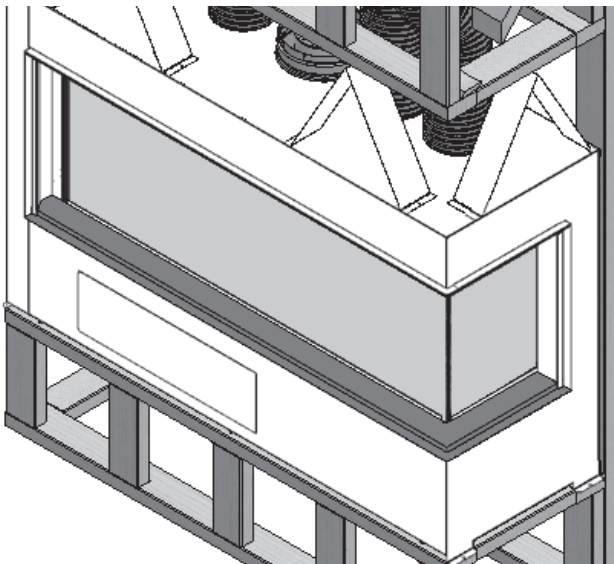

Install Barrier Screen

⚠ WARNING

FOR SAFETY PURPOSE, ensure the barrier screen is installed on the fireplace.

Install the barrier screen onto the appliance.

1. Place the side screen on the base plate of the appliance opening, magnets inboard against plate flange. Push top against top plate flange.
2. Place the front screen on the base plate of the appliance opening, magnets inboard against plate flange. Push top against top plate flange.
Note: The front screen frame overlaps the side screen frame.
3. Ensure that the screens are secure.

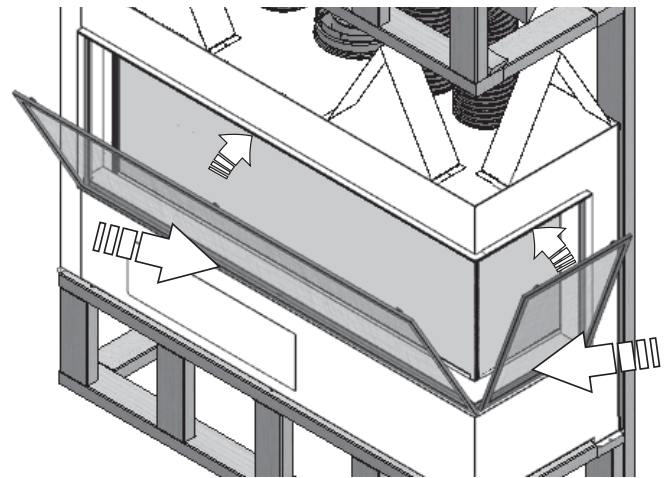

Install Remote Control Handset Wall Holder

The remote control kit for this fireplace comes complete with a wall-mounted holder. This holder is not required in all installations but is provided as an optional feature for those customers who wish to mount the remote handset to the wall.

To install the holder to the wall, find a convenient location and use the hardware provided with the kit. See the diagram below for required hardware and configurations. Note that the holder can be installed at the base of a light switch plate.

IMPORTANT. The location of the remote control handset is important to assure proper temperature regulation. To obtain a constant temperature, we recommend that the handset should be between 3 and 15 feet away from the appliance **but not directly above it**. We also advise that the handset should be located away from any other heat source and not in direct sunlight as this may affect the temperature sensor located in the remote handset.

WIRING DIAGRAM

NOTE - ALL WIRING IS SPECIFIC TO THIS APPLIANCE
SHOULD ONLY BE REPLACED WITH ORIGINAL
EQUIPMENT WIRING FROM THE MANUFACTURER

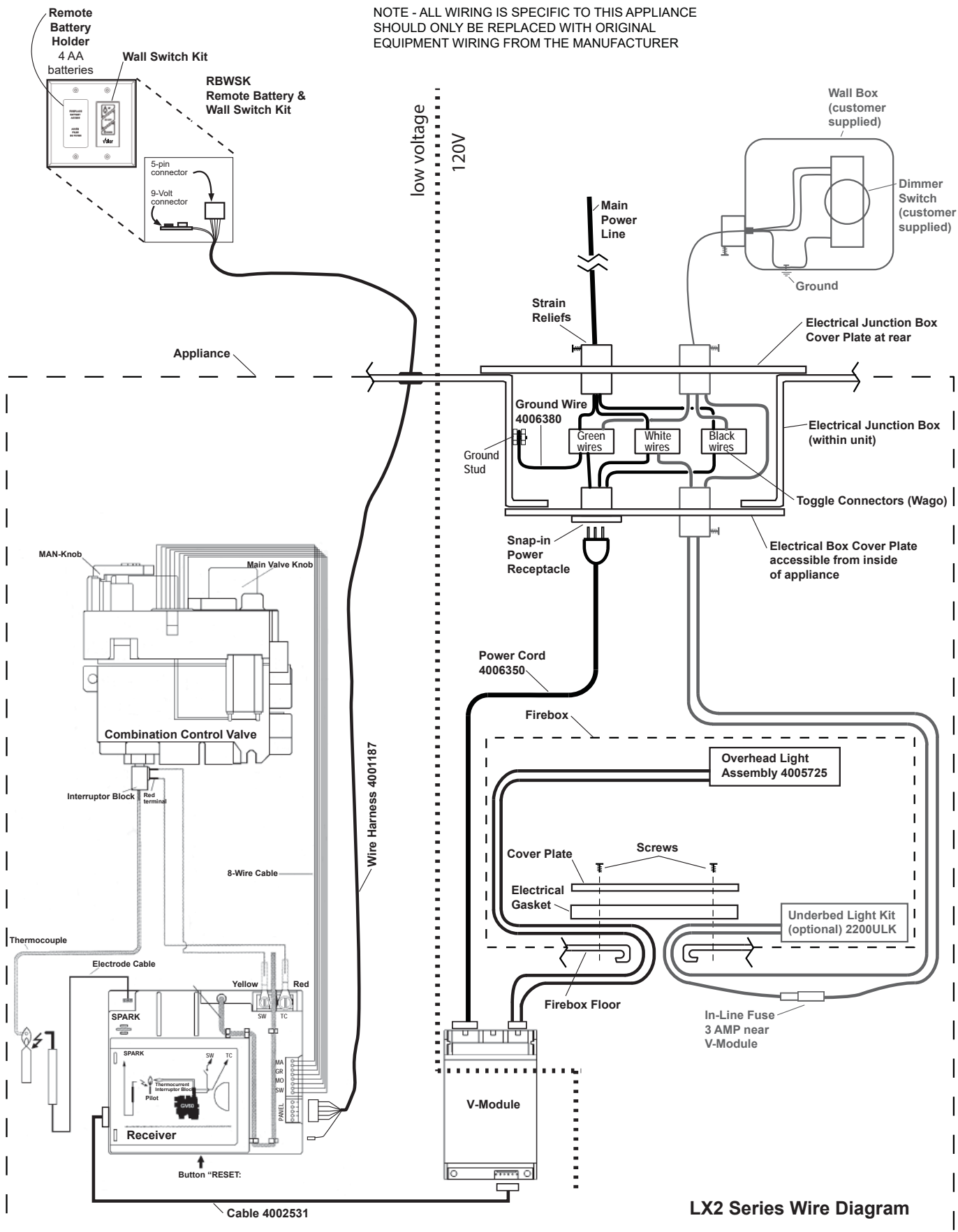

LX2 Series Wire Diagram

APPROVED VENTING COMPONENTS

Approved Direct Vent Suppliers - Valor Models 2200J

		Venting Parts Description	Venting Parts Code / availability by Manufacturer									
			DURA-VENT 4 x 6-5/8"	DURA-VENT 5 x 8"	SELKIRK	ICC EXCEL DIRECT	SECURE VENT	RLH INDUSTRIES	AMERIVENT	MILES INDUSTRIES	BDM	
Termination Caps	Horizontal	Standard Co-axial	46DVA-HC	58DVA-HC	4DT-HC	—	—	—	—	658DVK2	940160	
		Deluxe Co-axial	—	—	—	—	—	—	4DHCS square	—	940160	
		High Wind Co-axial	—	—	—	—	SV4CHC	—	—	—	—	
	Vertical	Standard Co-axial	46DVA-VC	58DVA-VC	4DT-VT	TM-4VT	—	HSDV4658-1313	4DVC	—	940264	
		High Wind Co-axial	46DVA-VCH	58DVA-VCH	—	—	SV4CGV		—		—	—
		Extended Co-axial	46DVA-VCE	58DVA-VCE	—	—	—		—		—	—
			Snorkel, 14" Rise	—	—	4DT-ST14	TM-4ST14	—	—	4D14S	—	94040614
		Snorkel, 36" Rise	—	—	4DT-ST36	TM-4ST36	—	—	4D36S	—	94040636	
Adjustable Pipe Length and Pipe Extensions 4" x 6-5/8"	Galvanized or Black	46DVA-08A 46DVA-08AB (3" to 7")	—	—	4DT-ADJ 4DT-ADJ(B)	—	—	—	4D7A or 4D7AB (3" to 5")	—	94610608 (4" to 8-1/2")	
	Galvanized or Black	46DVA-16A 46DVA-16AB (3" to 14-1/2")	—	—	—	—	SV4LA SV4LBA	—	4D12A or 4D12AB (3" to 10")	—	94610616 (4" to 16")	
	Galvanized or Black	46DVA-17TA 46DVA-17TAB (11" to 17")	—	—	—	TC-4DLT TC-4DLTB	SV4LA12 SV4LBA12	—	4D16A or 4D16AB (3" to 14")	—	—	
	Galvanized or Black	46DVA-24TA 46DVA-24TAB (17" to 24")	—	—	—	—	SV4LA24 SV4LBA24	—	4D26A or 4D26AB (3" to 24")	—	—	
	Coaxial Flex	46DVA-48FF 46DVA-120FF	—	—	—	—	—	—	—	—	—	
	DV 45° Elbows	Galvanized	46DVA-E45	58DVA-E45	—	TE-4DE45	—	—	—	4D45L	—	94620645
Black		46DVA-E45B	58DVA-E45B	—	TE-4DE45B	SV4EBR45	—	—	4D45LB	—	94620645B	
Galvanized Swivel		—	—	4DT-EL45	—	SV4E45	—	—	—	—	—	
Black Swivel		—	—	4DT-EL45(B)	—	SV4EB45	—	—	—	—	—	
DV 90° Elbows	Galvanized	46DVA-E90	58DVA-E90	—	TE-4DE90	—	—	—	4D90L	—	—	
	Black	46DAV-E90B	58DAV-E90B	—	TE-4DE90B	SV4EBR90	—	—	4D90LB	—	—	
	Galvanized Swivel	—	—	4DT-EL90	—	SV4E90	—	—	—	—	94620690	
	Black Swivel	—	—	4DT-EL90(B)	—	SV4EB90	—	—	—	—	94620690B	

APPROVED VENTING COMPONENTS

**QUALIFIED
INSTALLER**

Venting Parts Description		Venting Parts Code / availability by Manufacturer									
		DURA-VENT 4 x 6-5/8"	DURA-VENT 5 x 8"	SELKIRK	ICC EXCEL DIRECT	SECURE VENT	RLH INDUSTRIES	AMERIVENT	MILES INDUSTRIES	BDM	
Pipes	6" long	Galvanized	46DVA-06	58DVA-06	4DT-06	TC-4DL6	SV4L6	—	—	—	94610606
		Black	46DVA-06B	58DVA-06B	4DT-06(B)	TC-4DL6B	SV4LB6	—	—	—	90410606B
	7" long	Galvanized	—	—	—	—	—	—	4D7	—	—
		Black	—	—	—	—	—	—	4D7B	—	—
	9" long	Galvanized	46DVA-09	58DVA-09	4DT-09	—	—	—	—	—	94610609
		Black	46DVA-09B	58DVA-09B	4DT-09(B)	—	—	—	—	—	94610609B
	12" long	Galvanized	46DVA-12	58DVA-12	4DT-12	TC-4DL1	SV4L12	—	4D12	—	94610612
		Black	46DVA-12B	58DVA-12B	4DT-12(B)	TC-4DL1B	SV4LB12	—	4D12B	—	94610612B
	18" long	Galvanized	46DVA-18	58DVA-18	4DT-18	—	—	—	—	—	94610618
		Black	46DVA-18B	58DVA-18B	4DT-18(B)	—	—	—	—	—	94610618B
	24" long	Galvanized	46DVA-24	58DVA-24	4DT-24	TC-4DL2	SV4L24	—	4D2	—	94610624
		Black	46DVA-24B	58DVA-24B	4DT-24(B)	TC-4DL2B	SV4LB24	—	4D2B	—	94610624B
	36" long	Galvanized	46DVA-36	58DVA-36	4DT-36	—	SV4L36	—	4D3	—	94610636
		Black	46DVA-36B	58DVA-36B	4DT-36(B)	—	SV4LB36	—	4D3B	—	94610636B
	48" long	Galvanized	46DVA-48	58DVA-48	4DT-48	TC-4DL4	SV4L48	—	4D4	—	94610648
		Black	46DVA-48B	58DVA-48B	4DT-48(B)	TC-4DL4B	SV4LB48	—	4D4B	—	94610648B
Flashings	Roof Flashing 0/12-6/12	46DVA-F6	58DVA-F6	4DT-AF6	TF-4FA	SV4FA	—	4DF (0/12-5/12)	—	949606012	
	Roof Flashing 7/12-12/12	46DVA-F12	58DVA-F12	4DT-AF12	TF-4FB	SV4B	—	4DF12 (6/12-12/12)	—	949606712	
	Flat Roof Flashing	46DVA-FF	58DVA-FF	—	TF-4F	SV4F	—	—	—	949606001	
	Masonry Flashing	—	—	—	TF-4MF	—	—	—	—	—	
	New Siding Flashing	—	—	—	—	—	—	—	658NSFK	—	
Various Venting System Parts	Wall Thimble	46DVA-WT	58DVA-WT	4DT-WT	TM-4WT	SV4RSM	—	4DWT	—	949064U	
	Storm Collar	46DVA-SC	58DVA-SC	4DT-SC	TM-SC	SV4AC	—	4DSC	—	94960608	
	Decorative Plate	46DVA-DC	58DVA-DC	4DT-CS	TM-4TR	SV4PF	—	4DFPB	—	94940612	
	Cathedral Ceiling Support	46DVA-CS	58DVA-CS	4DT-CCS	—	—	—	4DRSB	—	949506KT	
	Ceiling Firestop / Floor Support	46DVA-FS	58DVA-FS	4DT-FS	TM-CS	SV4BF SV4SD	—	4DFSP	—	94980612	
	Attic Radiation Shield / Firestop	—	—	—	TM-4AS	—	—	4DAIS12 (12") 4DAIS36 (36")	—	94930620A	
	Wall Strap	46DVA-WS	58DVA-WS	4DTWS	TM-WS	—	—	4DWS	—	949164	
	Vinyl Siding Standoff	46DVA-VSS	58DVA-VSS	4DT-VS	TM-VSS	SV4VS	—	4DHVS	—	94800615S	
	Elbow Strap / Offset Support	46DVA-ES	58DVA-ES	4DT-OS	TM-OS	—	—	—	—	949264	
	Terminal Guard	46DVA-WG	58DVA-WG	—	—	—	—	—	658TG	940164SHRD	

- Notes:
1. Follow instructions supplied with each manufacturer's components.
 2. **Unless otherwise specified, all the parts and assemblies from the above table are to be used with 4" x 6-5/8" pipes.**
 3. **Do not mix components from different vent manufacturers.**
 4. Termination caps manufactured by RLH Industries or American Metal Products are from Homestyle Chimney Collection and can be ordered in one of the following finishes: a) aluminium; b) black powder coated; c) solid copper.

State of Massachusetts Carbon Monoxide Detector/Vent Terminal Signage Requirements

For all side wall horizontally vented gas fueled equipment installed in every dwelling, building or structure used in whole or in part for residential purposes, including those owned or operated by the Commonwealth and where the side wall exhaust vent termination is less than seven (7) feet above finished grade in the area of the venting, including but not limited to decks and porches, the following requirements shall be satisfied:

1. INSTALLATION OF CARBON MONOXIDE DETECTORS. At the time of installation of the side wall horizontal vented gas fueled equipment, the installing plumber or gas fitter shall observe that a hard wired carbon monoxide detector with an alarm and battery back-up is installed on the floor level where the gas equipment is to be installed. In addition, the installing plumber or gas fitter shall observe that a battery operated or hard wired carbon monoxide detector with an alarm is installed on each additional level of the dwelling, building or structure served by the side wall horizontal vented gas fueled equipment. It shall be the responsibility of the property owner to secure the services of qualified licensed professionals for the installation of hard wired carbon monoxide detectors.

a. In the event that the side wall horizontally vented gas fueled equipment is installed in a crawl space or an attic, the hard wired carbon monoxide detector with alarm and battery back-up may be installed on the next adjacent floor level.

b. In the event that the requirements of this subdivision can not be met at the time of completion of installation, the owner shall have a period of thirty (30) days to comply with the above requirements; provided, however, that during said thirty (30) day period, a battery operated carbon monoxide detector with an alarm shall be installed.

2. APPROVED CARBON MONOXIDE DETECTORS. Each carbon monoxide detector as required in accordance with the above provisions shall comply with NFPA 720 and be ANSI/UL 2034 listed and IAS certified.

3. SIGNAGE. A metal or plastic identification plate shall be permanently mounted to the exterior of the building at a minimum height of eight (8) feet above grade directly in line with the exhaust vent terminal for the horizontally vented gas fueled heating appliance or equipment. The sign shall read, in print size no less than one-half (1/2) inch in size, "GAS VENT DIRECTLY BELOW. KEEP CLEAR OF ALL OBSTRUCTIONS".

4. INSPECTION. The state or local gas inspector of the side wall horizontally vented gas fueled equipment shall not approve the installation unless, upon inspection, the inspector observes carbon monoxide detectors and signage installed in accordance with the provisions of 248 CMR 5.08(2)(a)1 through 4.

(b) EXEMPTIONS: The following equipment is exempt from 248 CMR 5.08(2)(a)1 through 4:

1. The equipment listed in Chapter 10 entitled "Equipment Not Required To Be Vented" in the most current edition of NFPA 54 as adopted by the Board; and
2. Product Approved side wall horizontally vented gas fueled equipment installed in a room or structure separate from the dwelling, building or structure used in whole or in part for residential purposes.

(c) MANUFACTURER REQUIREMENTS - GAS EQUIPMENT VENTING SYSTEM PROVIDED. When the manufacturer of Product Approved side wall horizontally vented gas equipment provides a venting system design or venting system components with the equipment, the instructions provided by the manufacturer for installation of the equipment and the venting system shall include:

1. Detailed instructions for the installation of the venting system design or the venting system components; and
2. A complete parts list for the venting system design or venting system.

(d) MANUFACTURER REQUIREMENTS - GAS EQUIPMENT VENTING SYSTEM NOT PROVIDED.

When the manufacturer of a Product Approved side wall horizontally vented gas fueled equipment does not provide the parts for venting the flue gases, but identifies “special venting systems”, the following requirements shall be satisfied by the manufacturer:

1. The referenced “special venting system” instructions shall be included with the appliance or equipment installation instructions; and
2. The “special venting systems” shall be Product Approved by the Board, and the instructions for that system shall include a parts list and detailed installation instructions.

(e) A copy of all installation instructions for all Product Approved side wall horizontally vented gas fueled equipment, all venting instructions, all parts lists for venting instructions, and/or all venting design instructions shall remain with the appliance or equipment at the completion of the installation.

WARRANTY

If you have a problem with this unit, please contact your dealer or supplier immediately. Under no circumstances should you attempt to service the unit in any way by yourself. The warranties in paragraphs 1 and 2 are provided only to the initial owner of this unit, are not transferable and are subject to the conditions and limitations in paragraphs 3, 4 and 5. Please review the conditions and limitations carefully and strictly follow their requirements.



1. Extended Warranty Coverage

For a period of up to ten (10) years, Miles Industries Ltd., (the "Company") or its appointed distributor will at its option pay the initial owner for the repair of, or will exchange the following parts or components which are found to be defective in material or workmanship under normal conditions of use and service:

Part or Component	Defect Covered	Maximum Warranty Period
Exterior steel casing	Corrosion	10 years
Glass	Loss of structural integrity	10 years
Cast iron parts	Corrosion	10 years
Firebox and heat exchanger	Corrosion (but not discoloration) causing loss of structural integrity	10 years

2. Two-Year Parts Warranty

In addition, for two (2) years from the date of purchase, the Company, at its option, can repair or exchange all parts and components not listed above but that are found to have a *bona fide* defect in material or workmanship under normal conditions of use.

3. Conditions and Limitations

- a) The warranty registration card must be completed by the initial owner and returned to the Company within 90 days of purchase. Alternatively, the warranty registration form may be filled out online at www.valorfireplaces.com.
- b) Installation and maintenance must be performed by an authorized and trained dealer in accordance with the Company's installation instructions.
- c) This warranty is void where installation of the unit does not conform to all applicable codes including national and local gas appliance installation codes and building and fire codes.
- d) The owner must comply with all operating instructions.
- e) The Company is not responsible for the labor costs to remove defective parts or re-install repaired or replacement parts.
- f) The initial owner of the unit will be responsible for any shipping charges for replacement parts as well as travel time incurred by the dealer to perform the warranty work.
- g) This warranty applies to non-commercial use and service and is void if it is apparent that there is abuse, misuse, alteration, improper installation, accident or lack of maintenance to the unit.
- h) This warranty does not cover damage to the unit due to:
 - i) Improper installation, operational or environmental conditions.
 - ii) Inadequate ventilation in the area or competition for air from other household equipment or appliances.
 - iii) Chemicals, dampness, condensation, or sulphur in the fuel supply lines which exceeds industry standards.
- i) This warranty does not cover glass, log breakage or damage to the unit while in transit.
- j) The Company does not allow anyone to extend, alter or modify this warranty and assumes no responsibility for direct, indirect or consequential damages caused by the unit. State or provincial laws where the first purchaser or user resides may provide specific rights to extend this warranty and, if so, the Company's sole obligation under this warranty is to provide labor and/or materials in accordance with those laws.

4. Discharge of Liability

After two (2) years from the date of purchase, the Company may, at its option, fully discharge all obligations under this warranty by paying to the first owner the wholesale price of any defective parts.

5. No Other Warranty

All obligations to repair this unit are defined in this warranty. Some states or provinces may specifically mandate additional warranties on the part of manufacturers, but in the absence of such specific legislation, there is no other warranty or obligation expressed or implied.

SPARE PARTS

	Description	Part No.
1	Vent reducer - converts to 4 x 6-5/8"	58DVA-X46
2	Window assembly - left - LJN/LJP	4005724
	Window assembly - right - RJN/RJP	4005723
3	Side screen assembly	4006888X
4	Exhaust restrictors (2)	4005911
5	Rear panels retaining brackets (3)	4005907
6	End panel retaining bracket	4006740
7	Wire cover	4006270
8	Electrical passage gasket	4006274
9	Burner assembly	4006942AH
10	Media tray - rear	4005939BY
11	Pilot cover	4005940BY
12	Media tray - front	4005938BY
13a	Door gasket - front	4006238A
13b	Door gasket - side	4006238B
14	Window assembly - front	4005722
15	Silicone window seals (2)	4005846
16	Door handle	4006269
17	Door retainer assembly (2)	4005913
18	Hot Glass warning plate	4003093
19	Light assembly - upper	4005725
20	Bi-pin halogen bulb GY6.35 20 W (3)	4005700
21	Front screen assembly	4006887X
22	Burner module assy - natural gas	4006685S
	Burner module assy - propane gas	4006154S
23	Pilot assembly (natural gas)	4006738
	Pilot assembly (propane gas)	4006739
24	Thermocouple	4000061
25	Pilot injector #51 (natural gas)	4000735
	Pilot injector #30 (propane gas)	4000736
26	Pilot tube	4000732
27	Pilot hood 2-flame	4000730
28	Extended nut	4001855
29	Electrode	4001856
30	Gas orifice DMS #32 (natural gas)	4007000-32
	Gas orifice DMS #49 (propane gas)	4007000-49
31	Pilot gaskets (2)	4000715
32	Pilot stand extrusion	4006649
33	Air shutter	4006594
34	Pivot bracket	4006583
35	Module tray gasket - long (2)	4006256
36	Module tray gasket - short (2)	4006257

	Description	Part No.
37	Block/pipe connector	4006689
38	Gas supply line	4006688
39	Flex line c/w flare to flare fittings	4000345
40	GV60 Gas valve assy - natural gas	4003986X
	GV60 Gas valve assy - propane gas	4003987X
41	Thermocurrent interruptor	4001037
42	Nut olive - pilot fitting	220K913
43	V-Module	4002530
44	Receiver 'MAX'	4002422
45	Wire harness GV60	4001187
46	Yellow cable to interrupter	4002096
47	Red cable to interrupter	4001035
48	Ignition cable sleeve 530 mm	4002244
49	Ignition cable 500 mm	4001039
50	Handset wall holder	9000008
51	Handset MAX	4002251
52	Remote Battery & Wall Switch Kit	RBWSKX
52a	Junction box	4005527
52b	Cover plate & 4 screws	4005526
52c	Battery holder	4005525
52d	Cable tie	4005524
52e	Harness assembly	4005523
52f	Plate with magnets	4005391
52g	Long screws (4)	4001444
52h	Wall switch with 2 screws	4005522
52i	Battery cover assembly	4005390
53	Ceramic liner panels - complete set	
	Fluted Black Liners	2200FBL
	Limestone Liners	2200LML
54	Rear panel—center	
	Fluted Black	4003955
	Limestone	4005779
55	Rear panel—sides	
	Fluted Black (2)	4003727
	Limestone (2)	4005778
56	Ceramic panel retainers (3)	
	Fluted Black (2)	4006499X
	Limestone (2)	4006499X
57	Reflective Glass Liners	2200RGL
58	Panel retainers (3)	4006500X
59	Glass panels (3)	4005845

SPARE PARTS

	Description	Part No.
60	End panel (LJ and RJ appliances)	
	Fluted black end panel	2200FBP
	Limestone end panel	2200LMP
61	Reflective glass end panel	2200RGP
62	Murano Glass Set	2200DGM
63	1/2" clear fireglass	4004521
64	1/4" ceramic pads (8)	4006367
65	Murano glass platform - front	4005729
66	Murano glass platform - rear	4005738
67	Decorative Glass Set	2200DGS
68	1/2" clear fireglass (4 bags)	4004521
69	Long Beach Driftwood Kit	1705DWK
70	Rear log	4002938
71	LH end log	4002965
72	LH front log	4002967
73	Center cross log	4003721
74	RH rear log	4003928
75	RH Cross log	4003929
76	Brown beach pebble	4003082
77	Grey beach pebble (2)	4003083
78	Small grey beach pebble	4003086
79	White beach pebble (2)	4003084
80	Black beach pebble (2)	4003085
81	Small beige beach pebbles (2)	4003087
82	Grade 1A vermiculite, bagged	4002940
83	Rocks & Shale Set	1714RSS
84	LH twig	4001827
85	LH twig - short (2)	4001827S
86	RH twig (2)	4001828
87	Grey Rock S4-A (7)	4002338
88	Dark Grey Rock S4-A (5)	4002339
89	Grey Rock S4-B (5)	4002340
90	Dark Grey Rock S4-B (8)	4002341
91	No 7 Grey 5 Matte pitted rock	4002650
92	No 9 Grey 5 Matte rock (2)	4002652
93	No 11 Grey 3 Matte rock (2)	4002654
94	No 14 Grey 9 Gloss rock	4002657
95	No 16 Warm Grey 3 Gloss pitted rock (2)	4002659
96	No 17 Grey 5 Gloss pitted rock	4002660
97	Shale 3/4" - grey, black 0.5lb ea	4004792

	Description	Part No.
98	Split Wood Kit	1700SWK
99	Splinters grey, bagged	4005813
100	Small embers, bagged	4006134
101	Split Wood Logs	4006196
	Log #1	4006122
	Log #2	4006123
	Log #3	4006124
	Log #4	4006125
	Log #5	4006126
	Log #6	4006127
	Log #7	4006128
	Log #8	4006129
	Log #9	4006130
	Log #10	4006131
	Log #11	4006132
102	GV60 Valve Repair Kit	4004544

SPARE PARTS

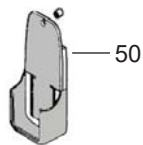
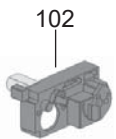
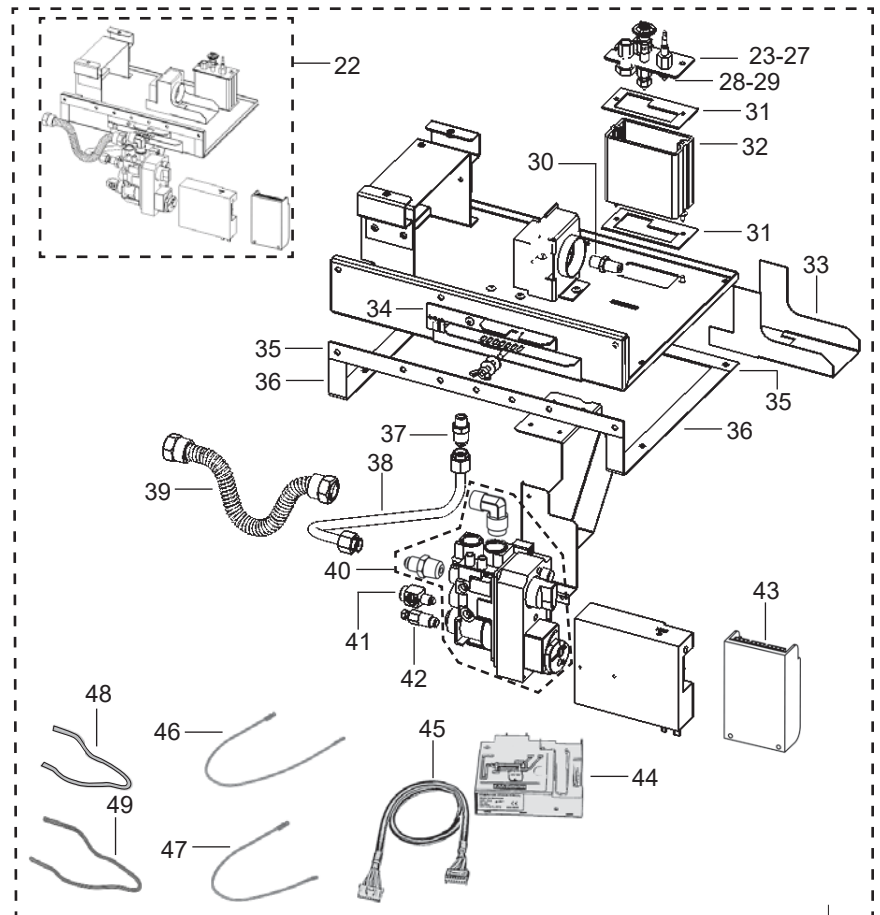
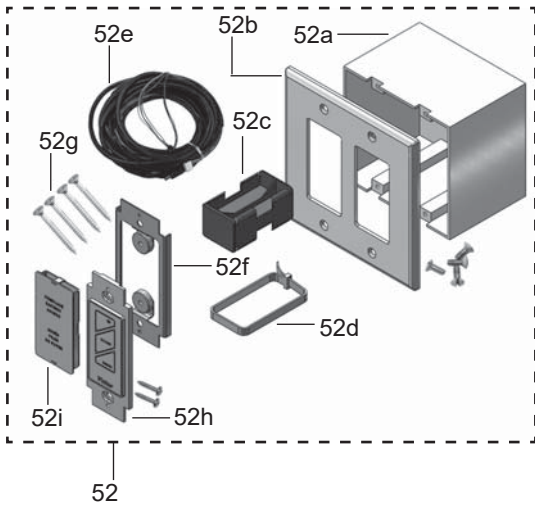
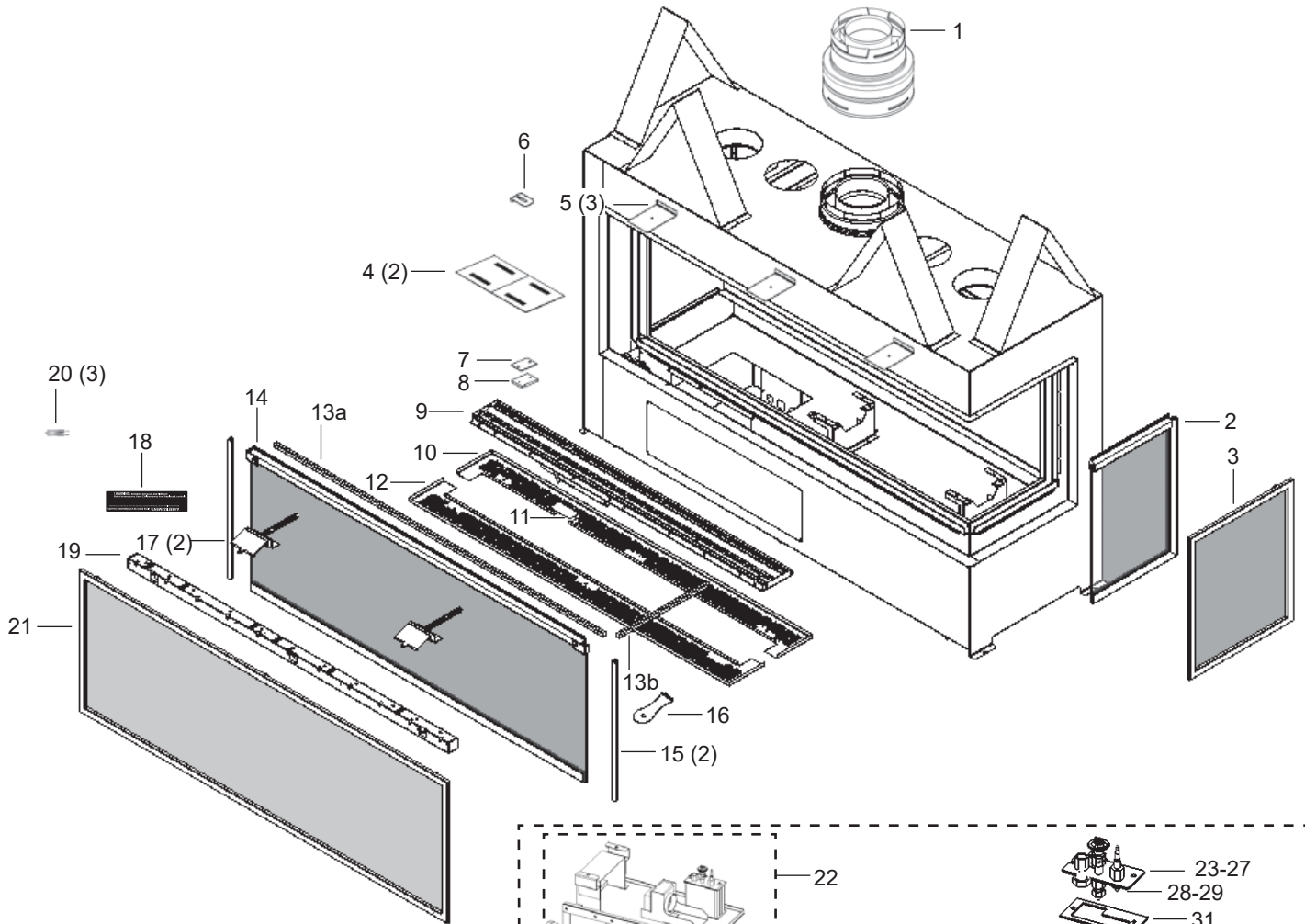

SPARE PARTS

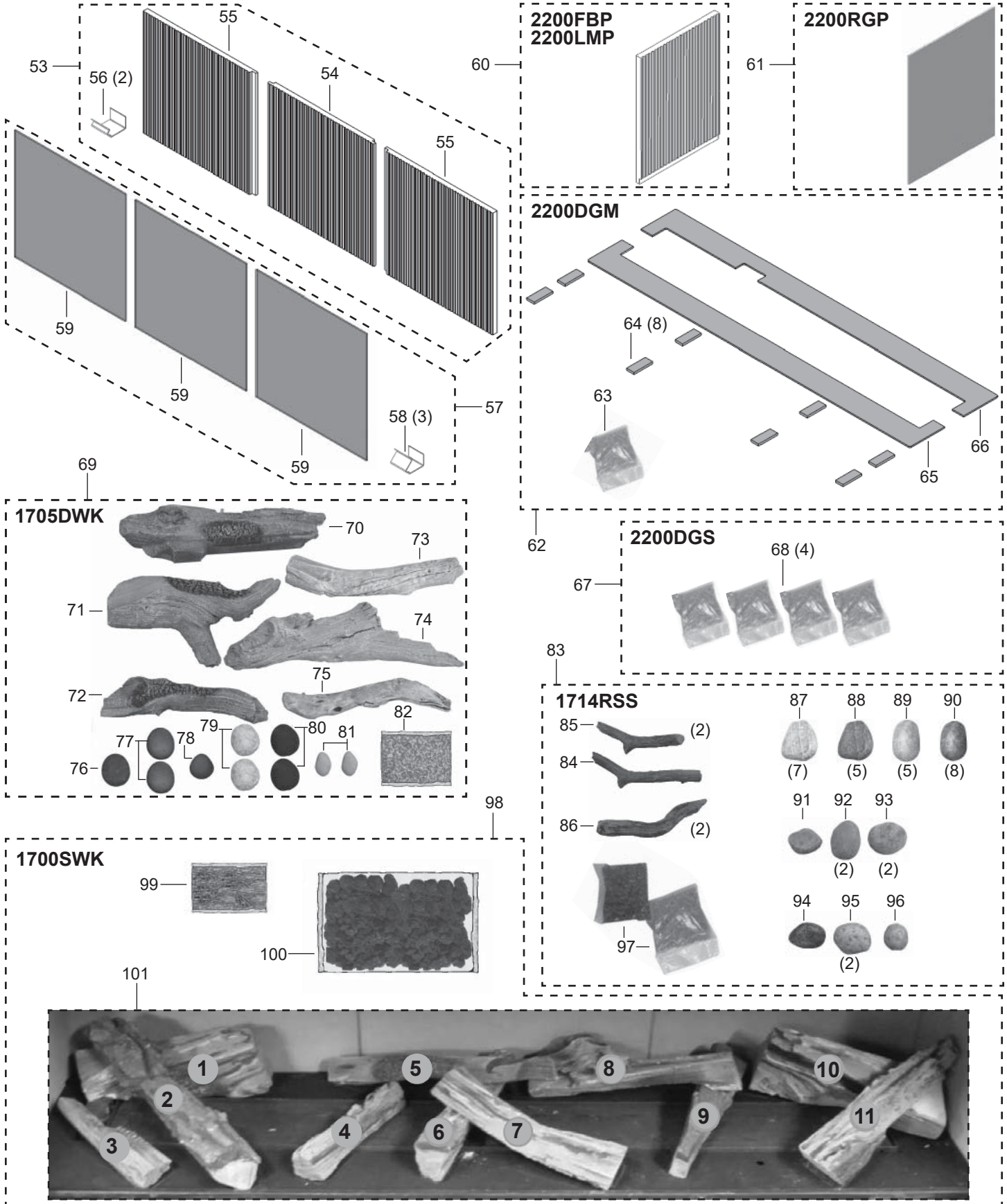

Thank You ...

For purchasing a Valor by Miles Industries. Your new radiant gas heater is a technical appliance that must be installed by a qualified installer.

Please fill in the information below. The information provided will be used for customer records only.



Fireplace Information

Model Number: 2200 LJN LJP RJN RJP

Serial Number:

Date Purchase (yyyy-mm-dd):

Dealer:

Customer Information

First Name:

Last Name:

Contact Information

Email:

Mailing Address

Address:

City:

Province/State:

Postal/Zip Code:

Country:

Cut out page, fill information, and mail to Miles Industries Ltd.

Online Warranty registration at www.valorfireplaces.com



Tape Shut



Fold here



Postage
needed

Miles Industries Ltd.
190 - 2255 Dollarton Highway
North Vancouver, BC V7H 3B1
Canada

Online Warranty registration at www.valorfireplaces.com



Thank you for choosing a Valor Product