

Installation Manual



L2

Direct Vent Zero Clearance
Gas Fireplace
natural gas 1700KN
propane gas 1700KP

Installer: Place model/serial number here.

Installer: Leave this manual with the appliance.
Consumer: Retain this manual for future reference.

⚠ WARNING:
FIRE OR EXPLOSION HAZARD
Failure to follow safety warnings exactly could result in serious injury, death, or property damage.

Do not store or use gasoline or other flammable vapors and liquids in the vicinity of this or any other appliance.

WHAT TO DO IF YOU SMELL GAS

- Do not try to light any appliance.

- Do not touch any electrical switch; do not use any phone in your building.
- Leave the building immediately.
- Immediately call your gas supplier from a neighbor's phone. Follow the gas supplier's instructions.
- If you cannot reach your gas supplier, call the fire department.

Installation and service must be performed by a qualified installer, service agency or the gas supplier.

⚠ DANGER



Hot glass will cause burns.
Do not touch glass until cooled.
Never allow children to touch glass.

A barrier designed to reduce the risk of burns from the hot viewing glass is provided with this appliance and must be installed for the protection of children and other at-risk individuals.

This appliance may be installed in an after-market permanently located, manufactured (mobile) home where not prohibited by local codes. This appliance is only for use with the type of gas indicated on the rating plate. This appliance is not convertible for use with other gases, unless a certified kit is used.

INSTALLER: Leave this manual with the appliance.
CONSUMER: Retain this manual for future reference.

Massachusetts:

The piping and final gas connection must be performed by a licensed plumber or gas fitter in the State of Massachusetts. Also, see Carbon Monoxide Detector requirements, page 64.

⚠ WARNING

This product can expose you to chemicals including Benzene, which is known to the State of California to cause cancer and birth defects or other reproductive harm. For more information go to www.P65Warnings.ca.gov.

Note: Natural gas, in its original state, contains Benzene.

This manual contains instructions to install the **ENGINE ONLY**. A trim kit is **REQUIRED** to complete the installation. A barrier screen is provided with the trim kit. **Refer to the manual supplied with the trim for installation.**

This appliance is a domestic room-heating appliance. It must not be used for any other purposes such as drying clothes, etc.

This appliance is suitable for installation in a bedroom or bed sitting room.

Ce guide est disponible en français sur demande.



We recommend a US Certified National Fireplace Institute (NFI) specialist install our gas hearth products.



The information contained in this manual is believed to be correct at the time of printing. Miles Industries Ltd. reserves the right to change or modify any information or specifications without notice. Miles Industries Ltd. grants no warranty, implied or stated, for the installation or maintenance of your heater, and assumes no responsibility for any consequential damage(s).

© Copyright Miles Industries Ltd., 2024. All rights reserved.
Designed and manufactured for Miles Industries Ltd.

Welcome to Valor®

This appliance has been professionally installed by:

Dealer Name: _____

Phone: _____

Fireplace Safety	4
Specifications	6
Kits & Accessories.....	7
Dimensions & Location.....	8
Installation Planning.....	9
Before Installing.....	9
Overview	10
Mantel Clearances	11
Framing.....	13
Wall Finish	16
Material Specifications	16
Non-Combustible Cement Board.....	16
Avoiding Cracking Wall Finishes.....	18
Venting.....	19
Overview	19
Co-Axial	20
Typical Co-axial Venting Components	20
Venting Chart.....	21
Restrictor Settings	22
Horizontal Vent Termination	23
Vertical Vent Termination	24
Co-Linear Conversion.....	25
Applications.....	25
Existing Fireplace Preparation	25
Complete installation into fireplace cavity	26
Partial Installation Into an Existing Fireplace	27
Installation Into an Adjacent Chimney.....	28
Example of co-linear conversion accessories.....	29
Installation	30
Appliance Preparation	30
Unpack Appliance	30
Fit Standoffs.....	30
Remove Heat Shield.....	30

Please read this manual BEFORE installing and operating this appliance.

Convert from Top to Rear Outlet (if required).....	31
Fit Appliance into Framing	32
Remove Window	33
HeatShift™ System—if used	34
Remove Convection Baffle	34
Install HeatShift Take-Off Collars to Appliance....	34
Electrical Wiring	35
Gas Supply.....	37
Liners	39
Fuel Beds	41
Driftwood Kit 1705DWKV2	41
Decorative Glass Murano 1700DGM.....	44
Rocks & Shale Set 1714RSS.....	45
Splitwood Kit 1705SWKV2	48
Birch Kit 1705BLKV2	51
Window Re-Installation & Checking	54
Wall Switch.....	55
Remote Control Pairing.....	57
Checking Operation and Aeration	59
Trim & Barrier Screen.....	60
Wiring Diagram.....	61
Approved Venting Components	62
Commonwealth of Massachusetts	64
Appendix A—Lighting Instructions.....	66
Appendix B—Remote Control Operation	67
Appendix C—Wall Switch Operation	74
Appendix D—HeatShift System	75
Appendix E—Spare Parts	96

Fireplace Safety

This manual contains very important information about the safe installation and operation of the fireplace. Read and understand all instructions carefully before installing and operating the fireplace. Failure to follow these instructions may result in possible fire hazard and will void the warranty.

Replacement manuals are available by contacting the Valor Customer Service at 1-800-468-2567, or by visiting valorfireplaces.com.

WARNING: Extremely Hot!

Heat and flammability

- Some parts of the fireplace are extremely hot, particularly the glass windows. Use the barrier screens provided or a gate to reduce the risk of severe burns.
- The glass windows can exceed 500°F at full capacity.
- Always keep the appliance clear and free from combustible materials, gasoline, and other flammable vapors and liquids.
- Be aware of hot wall surfaces! The walls directly above the fireplace can get very hot when the fireplace heats. Although safe, it may reach temperatures in excess of 200°F (93°C) depending on choice of optional accessories. Do not touch!
- Be aware of hot hearth/floor surfaces! Any projections directly around the fireplace can get very hot when the fireplace heats. Although safe, they may reach temperatures in excess of 200°F (93°C) depending on elevation of hearth. Be careful of touching these! Temperature of projection surfaces will be reduced when barrier screens are installed.
- Some materials or items, although safe, may discolor, shrink, warp, crack, peel, and so on because of the heat produced by the fireplace. Avoid placing candles, paintings, photos and other combustible objects sensitive to heat or furniture within 36 inches (0.9 m) around the fireplace.
- Due to its high temperatures, the appliance should be located out of traffic areas and away from furniture and draperies.
- Clothing or flammable material should not be placed on or near the appliance.

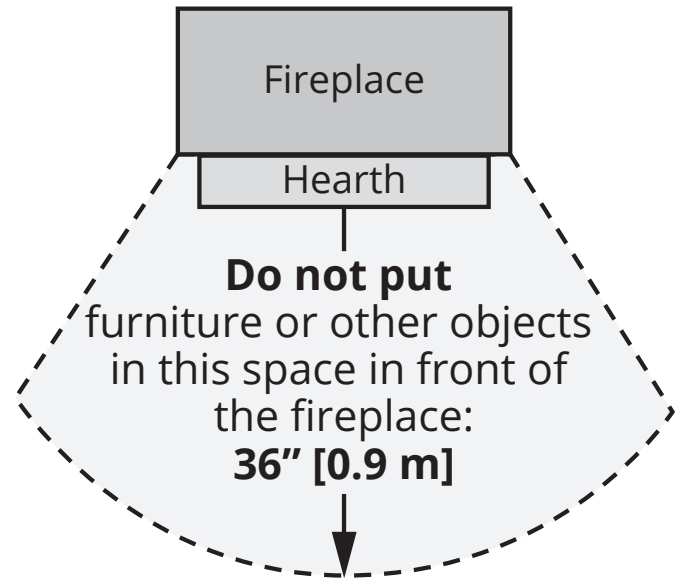

Barrier Screen and Safety

- A barrier designed to reduce the risk of burns from the hot viewing glass is provided with this appliance and shall be installed for the protection of children and other at-risk individuals.
- Children and adults should be alerted to the hazards of high surface temperature and should stay away to avoid burns or clothing ignition.
- Young children should be carefully supervised when they are in the same room as the appliance. Toddlers, young children, and others may be susceptible to accidental contact burns. A physical barrier is recommended if there are at-risk individuals in the house. To restrict access to a fireplace or stove, install an adjustable safety gate to keep toddlers, young children, and other at-risk individuals out of the room and away from hot surfaces.
- Any safety screen, guard, or barrier removed for servicing an appliance must be replaced prior to operating the appliance.

Fireplace Safety

Glass windows

WARNING

Do not operate this appliance with the glass front removed, cracked, or broken.

Do not strike or slam the glass front.

Replacement of the glass front should be performed by a licensed or qualified service person.

- The glass front assemblies must be in place and sealed before the unit can be placed into safe operation.
- The glass front assemblies must only be replaced as complete units, as supplied by the fireplace manufacturer. No substitute material may be used.
- Do not use abrasive cleaners on the glass front assemblies. Do not attempt to clean the glass when it is hot.

Venting

- This unit must be used with a vent system as described in this manual. No other vent system or components may be used.
- Never obstruct the flow of combustion and ventilation air. Keep the front of the appliance clear of all obstacles and materials for servicing and proper operation.
- This gas fireplace and vent assembly must be vented directly to the outside and must never be attached to a chimney serving a separate solid fuel burning appliance. Each gas appliance must use a separate vent system. Common vent systems are prohibited.

Intended use

- This appliance is designed and approved as a supplemental heater and provides the potential for most energy conservation when used while attended. The use of an alternate primary heat source is advisable.
- This unit is not for use with solid fuel.
- Do not use this heater as a temporary source of heat during construction.

Installation and Servicing

- Installation and repair should be done by a qualified service person. The appliance should be inspected before use and at least annually by a professional service person. More frequent cleaning might be required due to excessive lint from carpeting, bedding material, et cetera. It is imperative that control compartments, burners, and circulating air passageways of the appliance be kept clean.
- Do not use this appliance if any part has been under water. Immediately call a qualified service technician to inspect the appliance and to replace any part of the control system and any gas control that has been under water.

WARNING

Ceiling outlet
Front outlet
Side outlets

**HeatShift System:
Do not cover
or place items
in front of or
above outlet(s)!**

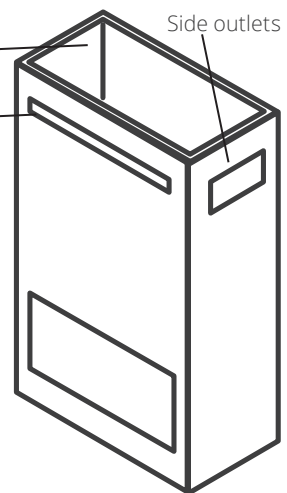

Specifications

Approval & Codes

This appliance is certified to ANSI Z21.88/CSA 2.33 American National Standard / CSA Standard for Vented Gas Fireplace Heaters for use in Canada and USA, and to CGA 2.17-91 High Altitude Standard in Canada. This appliance is for direct vent installations.

This appliance complies with CSA P.4.1-15 Testing method for measuring annual fireplace efficiencies.

The installation must conform to local codes or, in the absence of local codes, with the National Fuel Gas Code, ANSI Z223.1/NFPA 54 or the Natural Gas and Propane Installation Code CAN/CGA-B149.1. Only qualified licensed or trained personnel should install this appliance.

This appliance must be electrically grounded in accordance with local codes, or, in the absence of local codes, with the National Electrical Code, ANSI/NFPA 70 or the Canadian Electrical Code, CSA C22.1.

Ratings

Model	1700KN	1700KP
Gas	Natural	Propane
Altitude (Ft.)*	0-4,500 feet*	
Input Maximum (Btu/h)	36,000	36,000
Input Minimum (Btu/h)	21,000	22,500
Manifold Pressure (in w.c.)	3.7"	9"
Minimum Supply Pressure (in w.c.)	5"	11"
Maximum Supply Pressure (in w.c.)	10"	14"
Main Burner Injector Marking	DMS#32	DMS#49
Pilot Injector Marking	51	30
Min. Rate By-Pass Screw	220	160

*High Altitude Installations

Input ratings are shown in BTU per hour and are certified without deration for elevations up to 4,500 feet (1,370 m) above sea level.

For elevations above 4,500 feet (1,370 m) in USA, installations must be in accordance with the current ANSI Z223.1 and/or local codes having jurisdiction. Heating value of gas in some areas is reduced to compensate for elevation—consult your local gas utility to confirm.

For installations at elevations above 4,500 feet (1,370 m) in Canada, please consult provincial and/or local authorities having jurisdiction.

Supply Gas

Heater engine 1700KN uses natural gas.

Heater engine 1700KP uses propane gas.

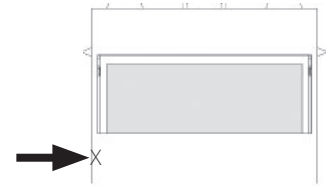

The supply pressure must be between the limits shown in the *Ratings* section.

The supply connection is 3/8" NPT male and located on the left hand side of the firebox. A shut-off valve (not supplied) is required on the supply line to isolate the unit during service. See *Gas Supply Installation* section for details.

Conversion Kits

The 1700K are supplied as natural gas or propane gas and are field convertible between fuels. See instructions packaged with the conversion kits for further information.

Electrical

The 1700K are designed to run on battery power and do not require an electrical power source to operate as a heater. However, they require electrical power to operate optional 1595CFKV2 Circulating Fan Kit, GV60WIFI WiFi Kit or 1270RBK Remote Blower Kit.

HeatShift™ System

The 1700K are designed to allow the installation of the optional HeatShift System, a convection system that redistributes the warm air flow away from the fireplace opening to a more desirable location using natural convection, without use of a fan.

The warm air flow may be relocated to a position higher up the wall, out the sidewalls, or even to another room. The result is much cooler wall temperatures above the fireplace opening for locating televisions, artwork, etc.

Please note that the framing and mantel clearances are affected by the installation of the HeatShift System. Refer to "Appendix D—HeatShift System" on page 75 for more information.

Outdoor Conversion Kit

The 1700K models are supplied standard for indoor applications and may be adapted for installation in specific "outdoor" applications protected from weather as defined in the GV60CKO outdoor conversion kit manual.

Kits & Accessories

Required Kits Information accurate at the time of printing and subject to change without notice.

Fuel Beds (choose one)		
1705DWKV2	Driftwood Kit	
1700DGM	Decorative Glass Murano Kit	
1714RSS	Rock & Shale Kit	
1705SWKV2	Split Wood Kit	
1705BLKV2	Birch Logs Kit	
Liners Panels (choose one)		
1715FBL	Fluted Black Liners	
1725RGL	Reflective Glass Liners (requires 1725RGL-3 Glass Retainer Kit)	
1760PBL	Plain Black Liners	
Trims (choose one)		Barrier Screen
1730CIK	Clean Install Kit - Fine Mesh - REQUIRES HeatShift	4007675
1750LSv2	Linear 3-1/2" Surrounds, various colors	4004221
1775LFB	Linear 1" Finishing Trim Black	4005562

Optional Accessories Information accurate at the time of printing and subject to change without notice.

Gas Conversion Kits	
1700KNGK	Conversion to natural gas
1700KPGK	Conversion to propane gas
Other Accessories	
GV60WIFI*	WiFi kits - REQUIRES GV60 V-module
GV60CKO*	Outdoor Fireplace Conversion Kit
1595CFKV2*	Circulating Fan Kit - REQUIRES GV60 V-module
1270RBK*	HeatSplit Remote Blower Kit
LDK	HeatShift System Kits (gravity flow) - MANDATORY with 1730CIK
Hearth Gate	Hearth gates such as Cardinal's VersaGate are available at retail stores carrying safety products for children.



WARNING

HeatShift System MUST be installed on this appliance when using 1730CIK—Clean Installation Kit!



WARNING

*** NO ELECTRICAL CONNECTION ALLOWED for any outdoor installation!**

Dimensions & Location

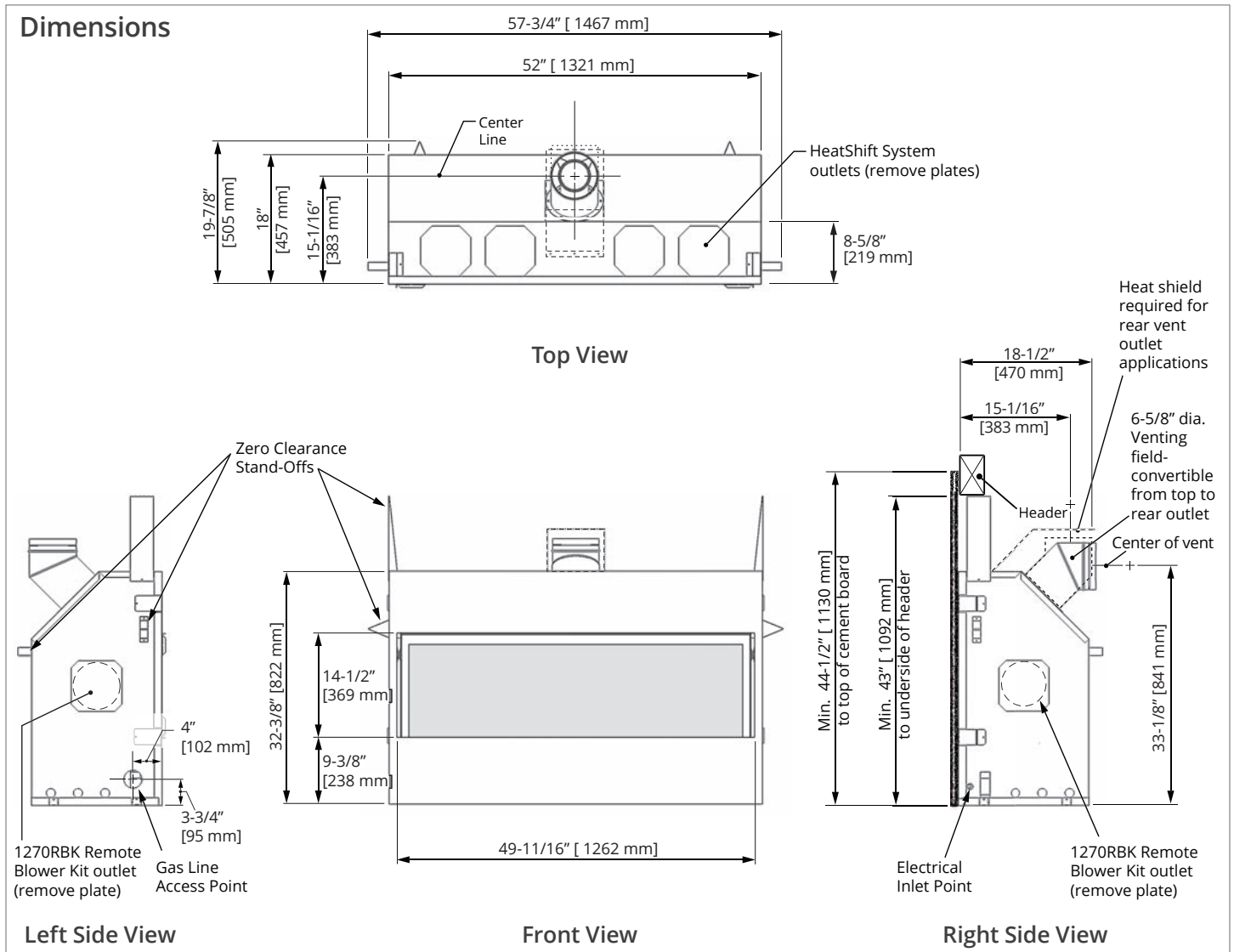

Location

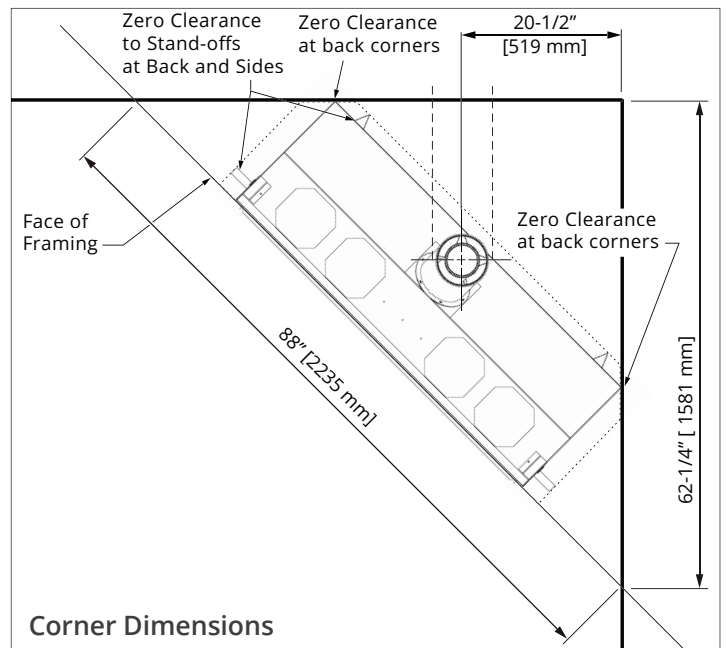
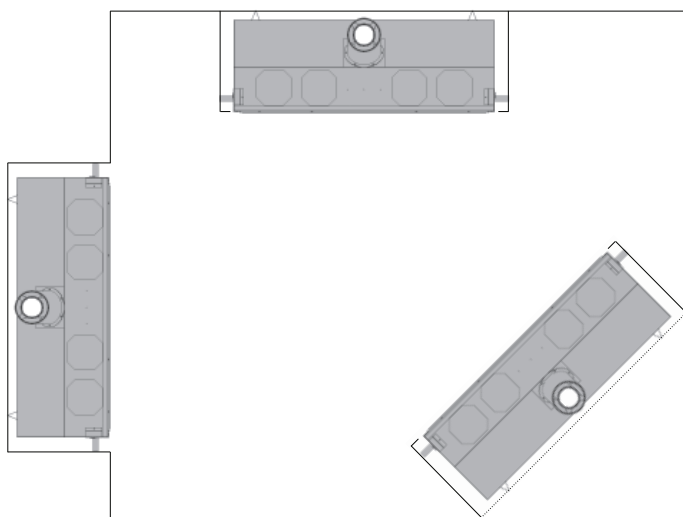

Installation Planning

Before Installing

Caution

Only qualified, licensed, or trained personnel should install this appliance.

1. YOU NEED TO KNOW FROM THE HOMEOWNER:
 - Will optional HeatShift System* be used;
 - Height of appliance and shelf, if used;
 - Thickness and type of wall finish around appliance;
 - Trim used*;
 - Other optional accessories used (if any);
 - Venting configuration.
2. Unpack the appliance, removing all items packed inside and around it. Recycle the packaging.
3. Check that you have everything, using the Pack Content sheet. Also, check that you have:
 - Fuel bed (packed separately);
 - Liner panels (packed separately);
 - Remote Battery and Wall Switch Kit;
 - HeatShift System components (if used);
 - Gas conversion kit (if necessary);
 - Venting accessories;
 - Electrical accessories (if used).
4. Carefully read the Installer's Checklist included with the fireplace for the installation sequence.

WARNING

***HeatShift System MUST be installed on this appliance when using 1730CIK—Clean Installation Kit!**

WARNING

NO ELECTRICAL CONNECTION ALLOWED for any outdoor installation!

Installation Planning

Overview

Note: This appliance may be installed in outdoor, weather protected environments as defined in the GV60CKO Outdoor Conversion Kit instruction manual.

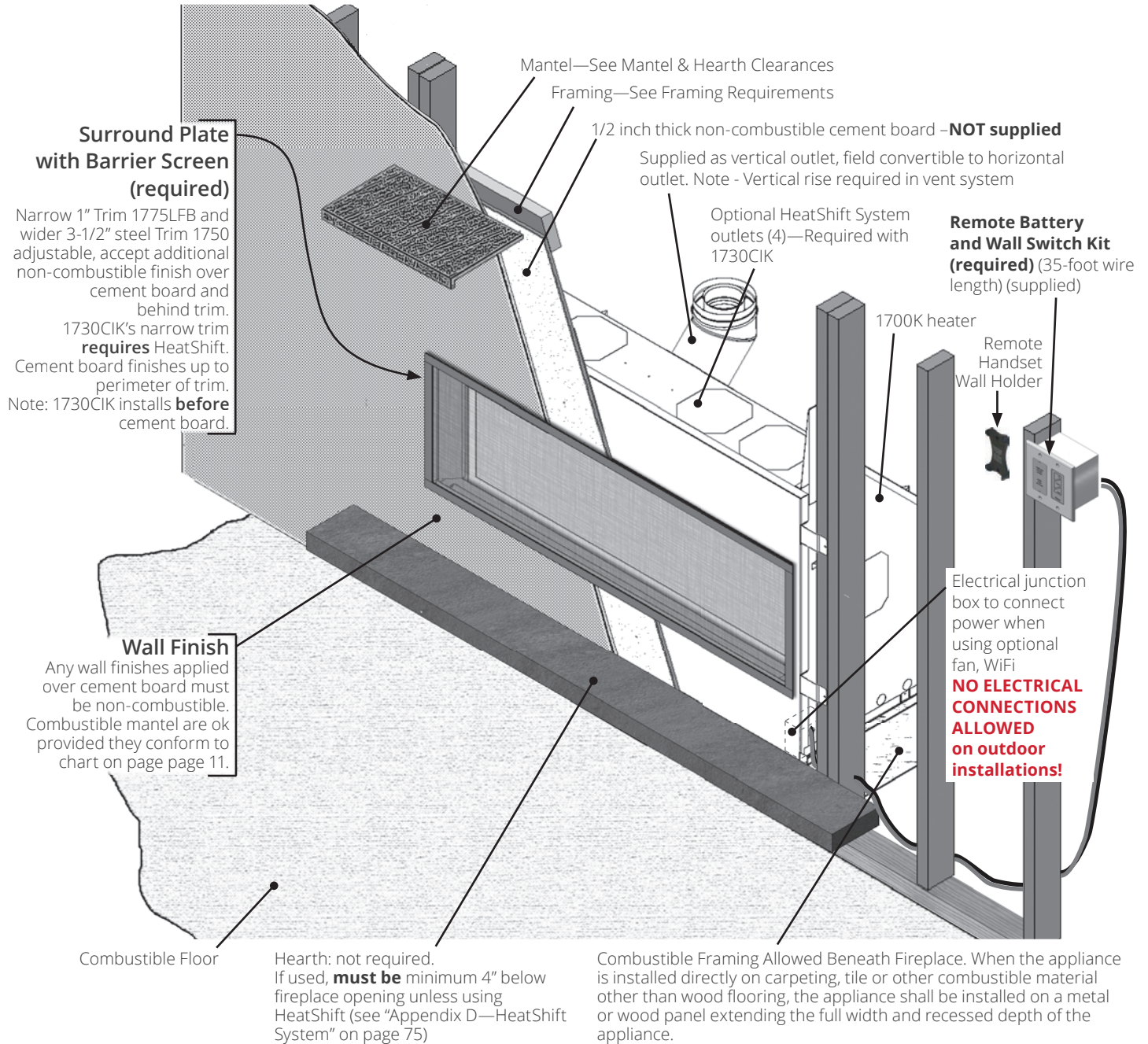

⚠ WARNING

Some materials or items, although safe, may discolor, shrink, warp, crack, peel, and so on because of the heat produced by the fireplace. Avoid placing candles, paintings, photos, and other items sensitive to heat around the fireplace.

⚠ WARNING

HOT WALL SURFACES! The wall directly above the fireplace is constructed of non-combustible materials and, although safe, it may reach temperatures in excess of 200°F (93°C) depending on choice of trims. Do not touch. Finish wall using materials suitable for these temperatures.

Installation Planning

Mantel Clearances

Combustible Mantel—Left Side View

NOTE

Use for the optional HeatShift System affects mantel and hearth clearances. See HeatShift section in Appendix D of this manual.



WARNING

HeatShift System **MUST** be installed on this appliance when using 1730CIK—Clean Installation Kit!

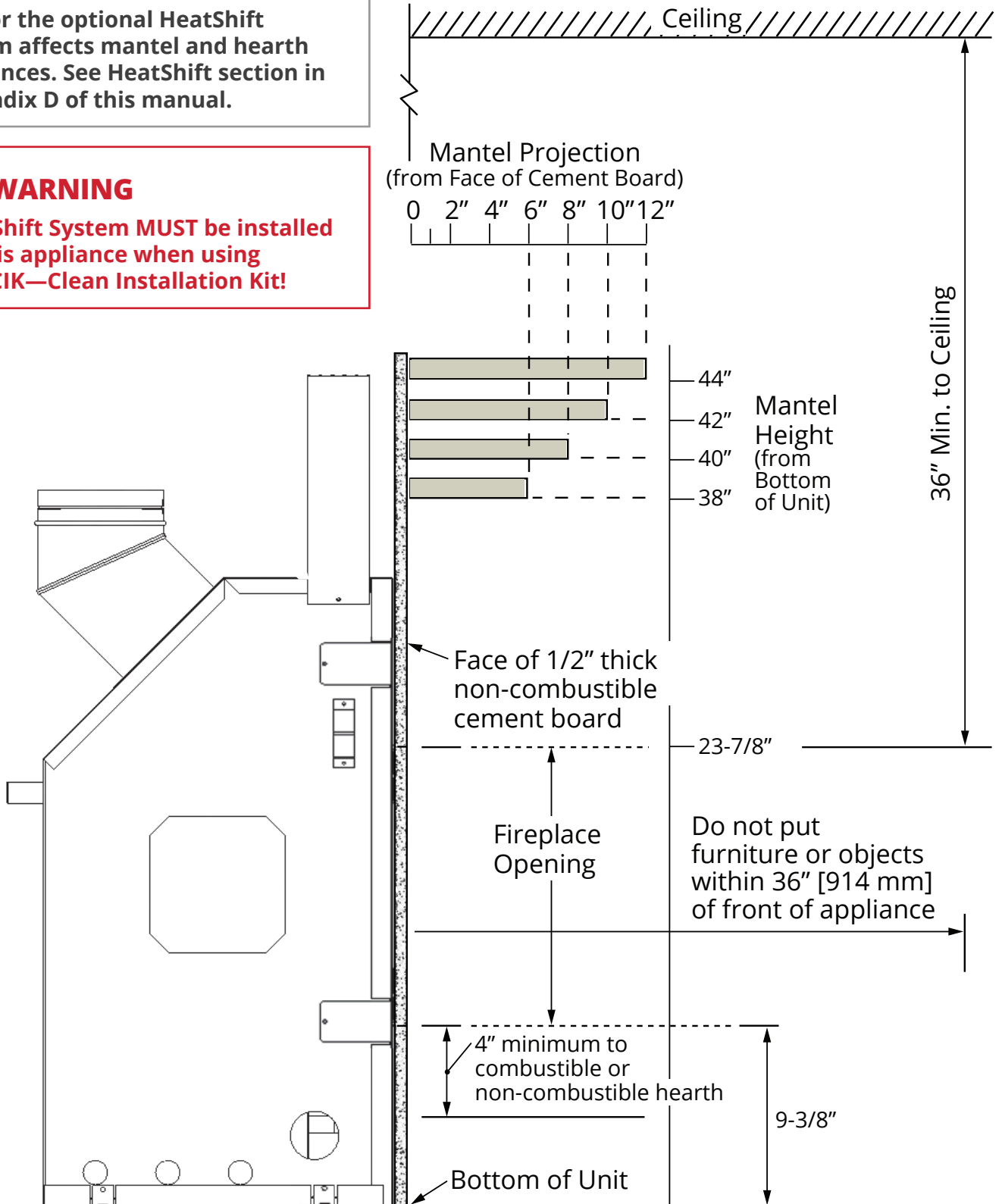

Installation Planning

Mantel Clearances

Combustible Sidewall / Mantel Leg—Top View

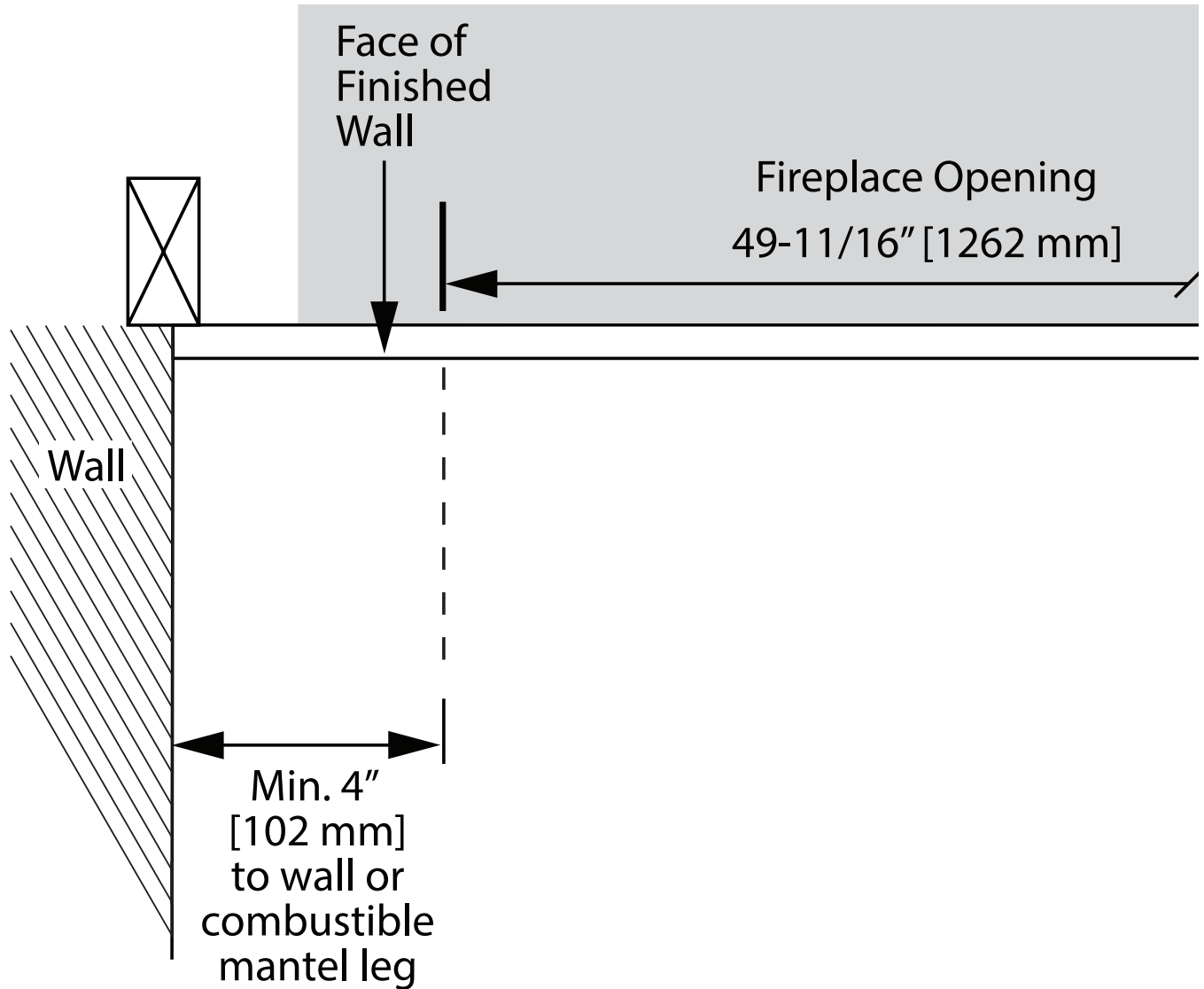

Installation Planning

Framing

Framing Dimensions

NOTE

Use of the optional HeatShift System affects mantel and hearth clearances. See HeatShift section in Appendix D of this manual.

⚠ WARNING

HeatShift System **MUST** be installed on this appliance when using 1730CIK—Clean Installation Kit!

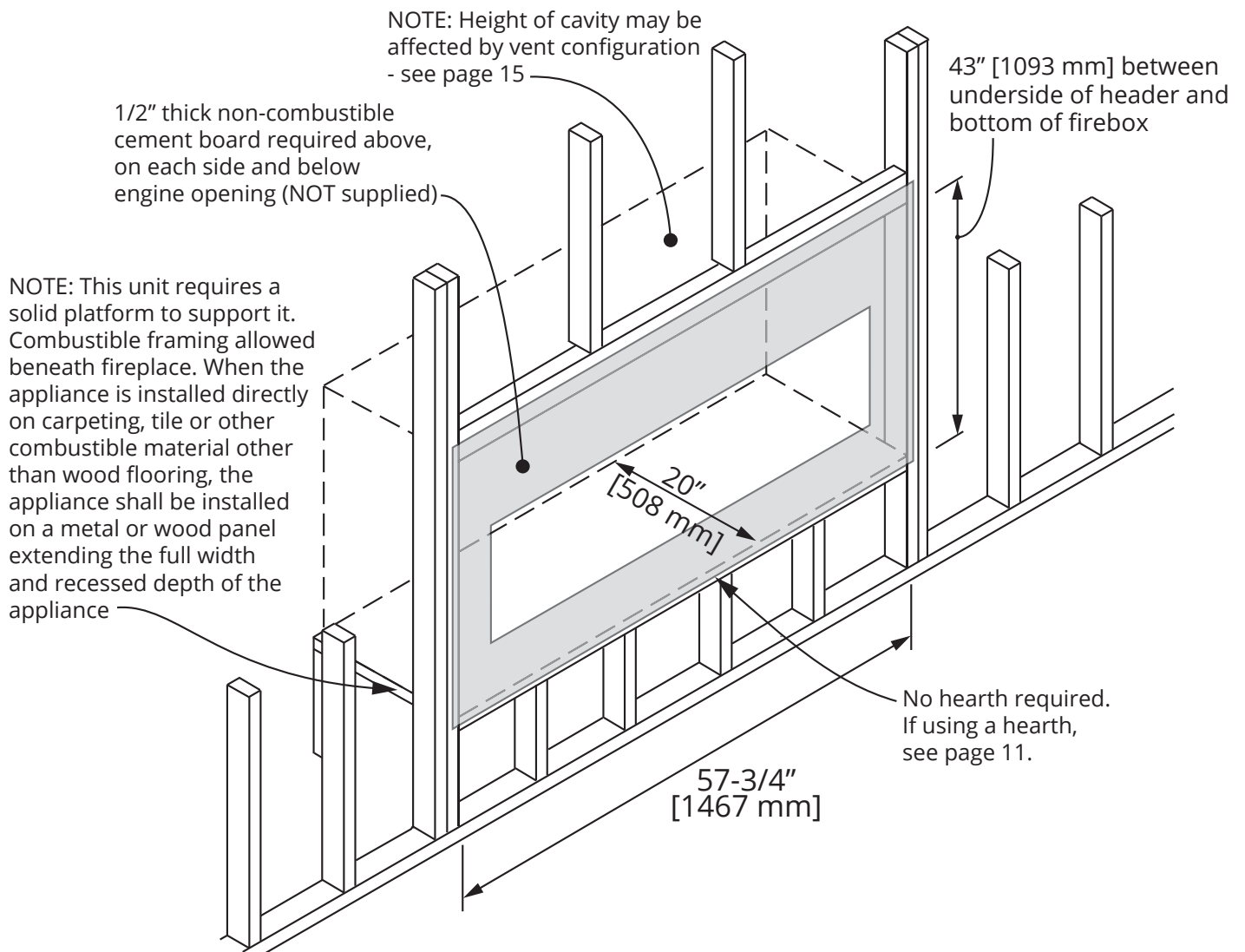

Installation Planning

Framing

Framing with Partial Shelf—Top Outlet

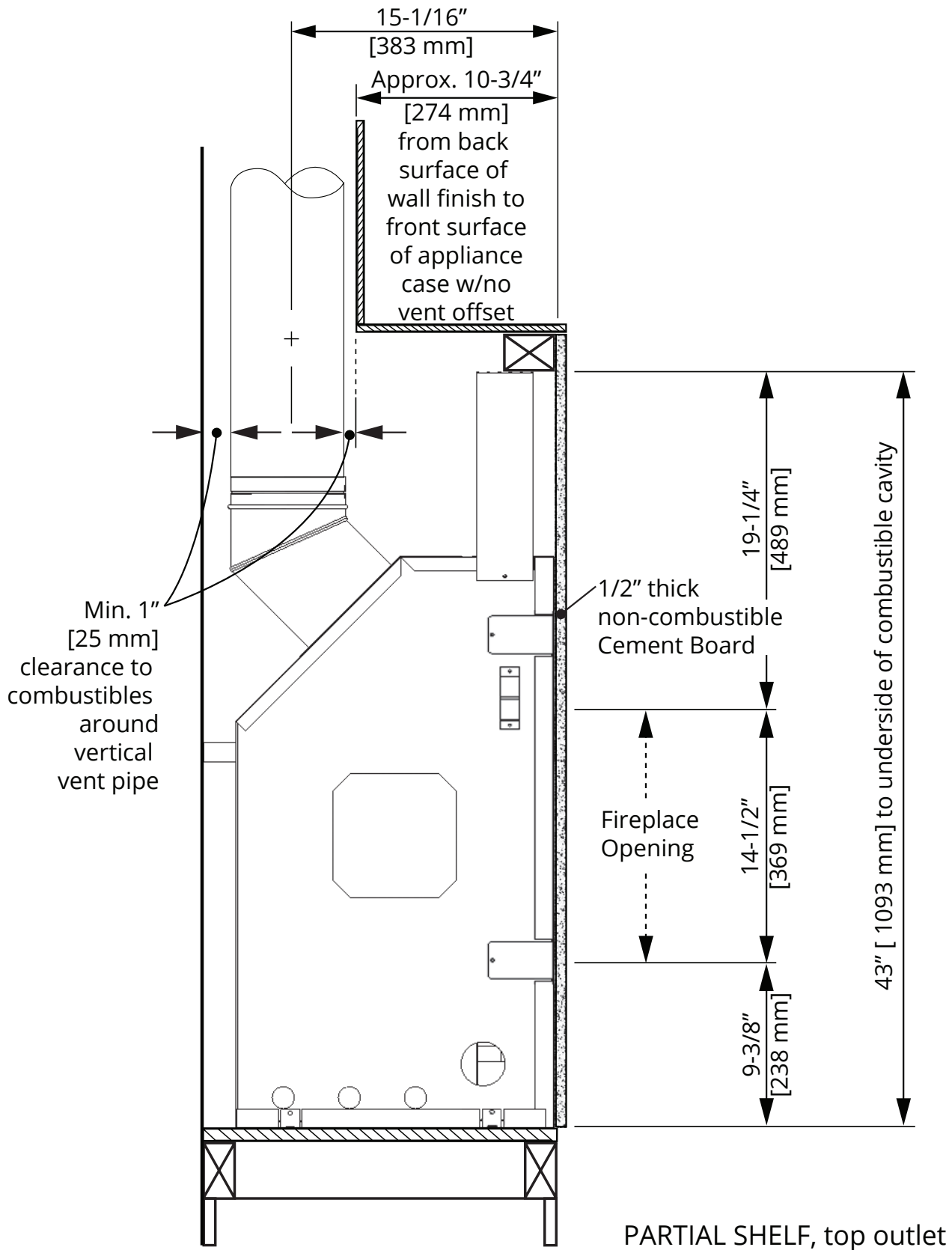

Venting Considerations—Vertical Takeoff

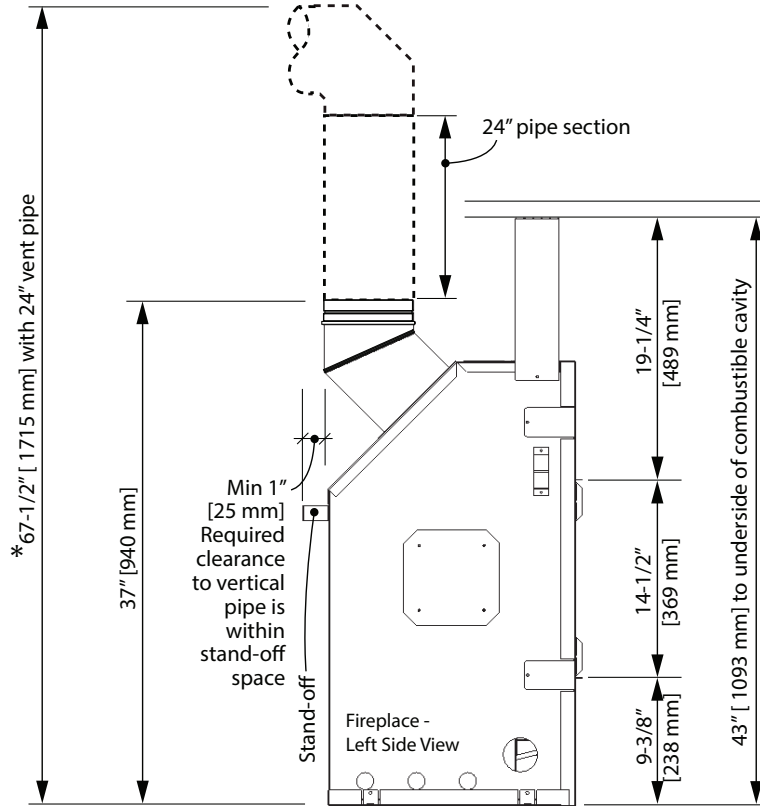

*Notes—ALL venting considerations

- Dimensions of venting are approximate and based on using Dura-Vent elbows. Elbow curve radius dimensions will vary when using other brands. In general, other brands have slightly bigger radius.
- Minimum 24 inches vertical pipe section required right at unit. Refer to venting chart on page 30 for allowable horizontal runs.
- 3 inches clearance to combustibles required above horizontal pipe. Slope horizontal pipe upwards 1/4 inch per foot. 1 inch clearance required around sides and bottom of horizontal pipe and around vertical pipe.
- When calculating effective pipe lengths subtract approximately 1-1/2 inch for pipe joint - for example, a 12 inches pipe section will add approximately 10-1/2 inches overall.

Venting Considerations—Horizontal Takeoff

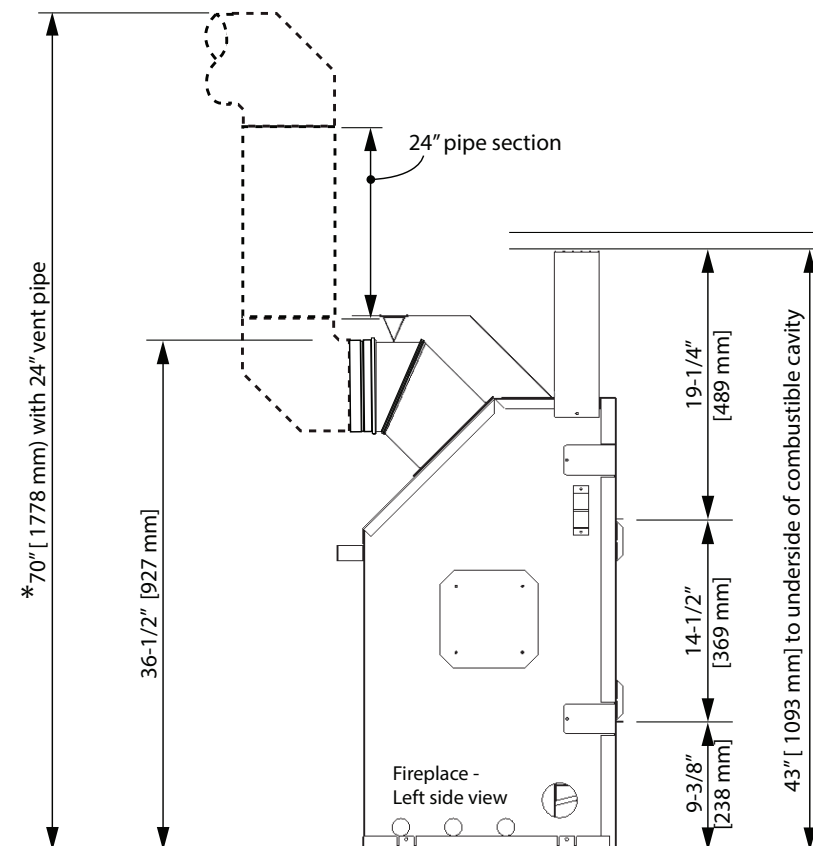

Installation Planning

Wall Finish

Material Specifications

Non-Combustible

Material which will not ignite and burn. Such materials are those consisting entirely of steel, iron, brick, tile, concrete, slate, glass or plasters, or any combination thereof.

Materials that are reported as passing ASTM E 136, Standard Test Method for Behavior of Materials in a Vertical Tube Furnace at 750°C shall be considered non-combustible materials.

Combustible

Materials made of or surfaced with wood, compressed paper, plant fibers, plastics, or other material that can ignite and burn, whether flame proofed or not, or plastered or unplastered shall be considered combustible materials.

Non-Combustible Cement Board

The L2 Linear fireplace requires a 1/2" (13 mm) thick non-combustible cement board to be used as a wall surface immediately surrounding the unit's opening—see diagram for minimum coverage.

Extending the cement board well beyond the minimum shown will help avoid cracking due to differential expansion of materials.

Pre-drill cement board with oversized holes and do not over-tighten screws to avoid cracking due to heat expansion.

Standard gypsum wall board may be used beyond the perimeter of the cement board.

Minimal coverage area of non-combustible cement board.
Any wall finish applied to shaded area must be non-combustible.

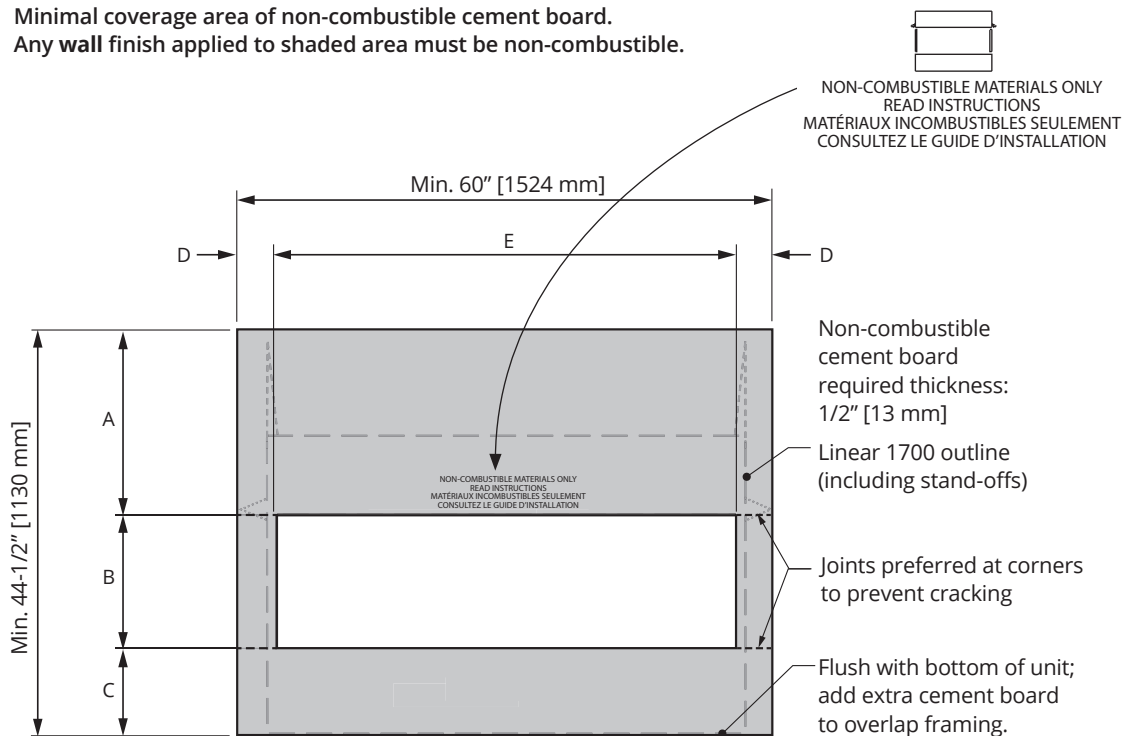

inches [mm]	With 1750 or 1775 trims	with 1730CIK kit
A	Min. 20-1/2 [521]	Min. 20-1/8 [511]
B	14-3/4 [375]	15-13/16 [401]
C	Min. 9-1/4 [235]	Min. 8-9/16 [218]
D	Min. 5 [127]	Min. 4-1/2 [114]
E	Min. 50 [1270]	Min. 51-1/16 [1296]

Installation Planning

Wall Finish

Non-Combustible Finishing Over Cement Board

Additional non-combustible material such as tile, etc., may be applied over top of the cement board or you may choose to leave it finished clean with no tile, etc.

Be aware that a trim is always required. Finish **should not cover** the trims.

1775 and 1750 Trims

Only the 1775 and 1750 style trims will accept tile, etc. tucked behind them (up to 5/8" thick for the 1775 and up to 1 inch thick for the 1750).

1730 Trim

1730 trim must be installed **BEFORE** cement board. Cement board and finishes are applied to the perimeter of the trim frame. Cement board and finish **CANNOT** be tucked under this trim.

Wider trim (1750) can adjust up to 1" forward of surface of cement board. Cement board tucks behind trim.

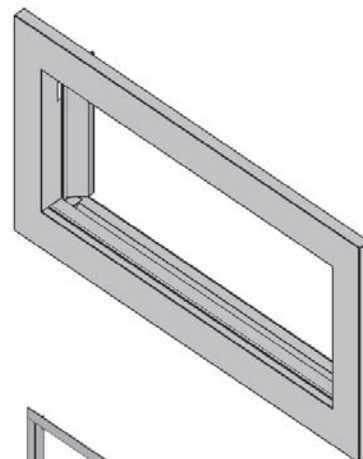

Narrow trim (1775) can adjust up to 5/8" forward of surface of cement board. Cement board tucks behind trim.

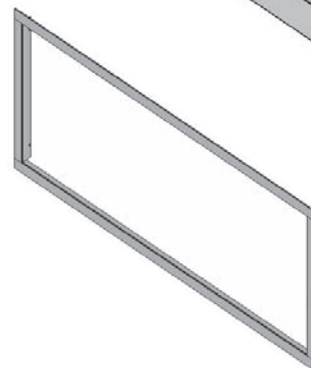

Clean Installation Kit 1730CIK requires HeatShift. Cement board finishes up to perimeter of frame. **Must install BEFORE cement board.**

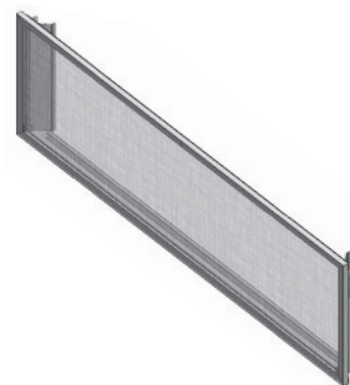

Installation Planning

Wall Finish

Avoiding Cracking Wall Finishes

We recommend installing the optional HeatShift System to reduce the wall temperatures and minimize the possibility of cracking wall finishes.

WARNING

HeatShift System MUST be installed on this appliance when using 1730CIK—Clean Installation Kit.

If a clean finish with no tile, etc. is desired, joints in the cement board and the transition to gypsum board will require special attention if future cracking is to be controlled. Be aware that temperatures on the non-combustible wall surface above the appliance can exceed 200°F (93°C).

Below are some tips on how to best avoid any cracking:

- Allow materials to dry thoroughly before finishing the wall. Cement board has the ability to absorb up to 30 percent of its weight in water and may shrink as much as 1/8" over a 48" length when drying from a saturated condition. Running the fireplace for an extended period before final finishing will help drive out moisture.

- Always pre-drill screw holes through cement board and use screws specific for material used.
- Always use mesh tape over joints.
- Always stagger joints in wall board.
- Behind joints, double up studs or use studs "on the flat" to add extra support to the joint. Adhesive on the backside of wall board behind any joints can help control differential movement.
- Use multiple, thinner coats of joint compound and allow to dry thoroughly between coats.
- Ensure framing materials are dry.
- After finishing the wall, introduce heat gradually to slowly dry any excess moisture rather than drying too fast.
- Avoid notching cement board or tiles around corners of window opening and instead provide a joint that intersects the corner.
- Avoid using large one-piece slab of material with a cut-out in the middle as a surround for the fireplace. Expansion above the opening will cause cracking at inside corners. Provide a joint that intersects the inside corner to avoid cracking.

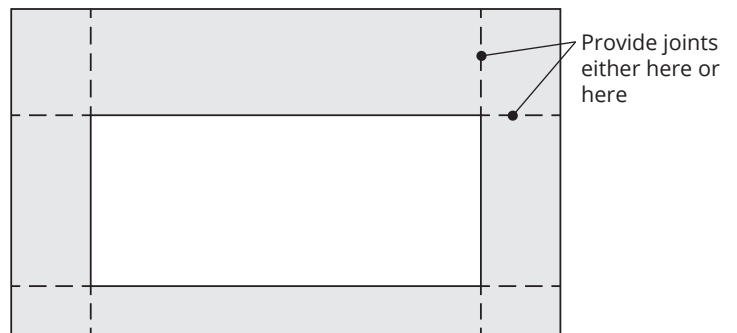
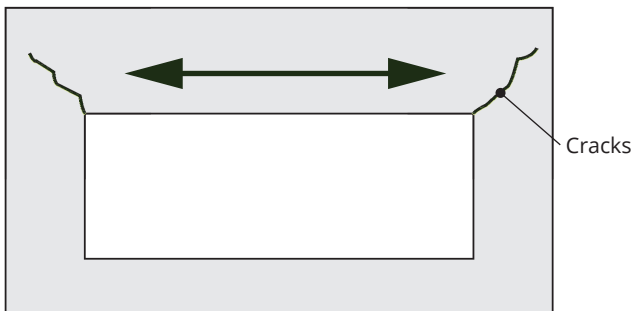

Top or Rear Outlet

This unit is supplied with a top vent outlet which can be field-converted to a rear vent outlet. See *Appliance Preparation* section for more information.

Vent Material

This unit is approved for installation using 4 x 6-5/8 inches co-axial direct vent pipe and accessories as listed in the *Approved Venting Components* section on page 62 of this manual. Follow the installation instructions supplied with the individual venting accessories.

This unit may also be converted to co-linear (1 x 3 in by 1 x 4 in) venting for use in solid-fuel burning fireplaces and chimneys using adapters and accessories—see list in the *Approved Venting Components* section on pages 61–62 of this manual.

Vent Sealing

Seal all **outer** coaxial pipe and elbow joints, including sectioned elbow **outer** joints, using high quality, high temperature 2 inch wide self-adhesive aluminum foil tape (Nashua-322-2 brand or similar). Wrap the tape completely around all **outer** joints and press firmly to seal.

A high temperature black silicone sealant may be used in the **outer** joints as a substitute to foil tape.

Ensure all the pipe joints have a minimum of 1 ¼ inch overlap.

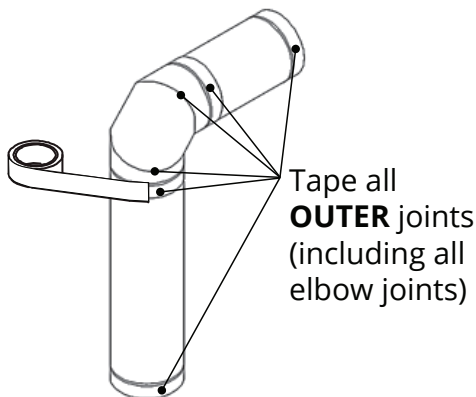

Wall Thickness

The appliance vent is suitable for penetrating a combustible wall assembly up to 8 inches in thickness. A non-combustible wall can be of any thickness up to the maximum horizontal run of vent pipe allowed for the particular installation.

Framing Vent in Combustible Walls & Ceilings

When penetrating through combustible walls and ceilings, frame a minimum of 10 in x 10 in opening and ensure that the insulation is kept clear of the vent pipe using either a wall thimble or an attic insulation shield. Follow the installation instructions supplied with the individual venting components.

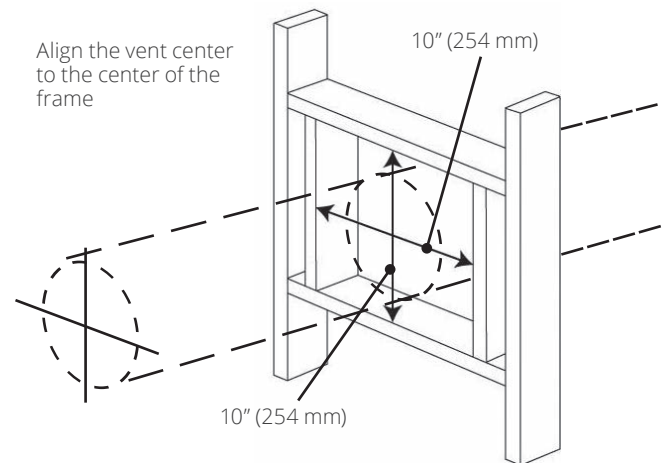

Important Installer Notice – Weather Sealing & Vapor Barriers

It is the installer's responsibility to ensure that vent installations through exterior walls are caulked and weatherproofed in such a manner as to:

- Prevent rain water from entering the wall from the weather side by adequately caulking the outer vent plate to the exterior wall surface.
- Prevent moisture inside the home from penetrating into the wall structure by ensuring the inside wall plate is adequately sealed to the inside vapor barrier.
- Prevent rain water and moisture from entering the walls by sealing the joints between the outer vent tube and the inner and outer wall plates.

We recommend the use of a high quality polyurethane sealant.

All horizontal pipe runs must be graded 1/4 inch per foot upwards in the direction of the exhaust flow. The final pipe length, when terminating through the wall may be graded downwards slightly to prevent water migration.

Typical Co-axial Venting Components

IMPORTANT

Provide support for vertical pipe runs, particularly offsets. Do not rely on the appliance for support of long vertical pipe runs. Horizontal pipe runs should be supported every 4 feet using strapping.

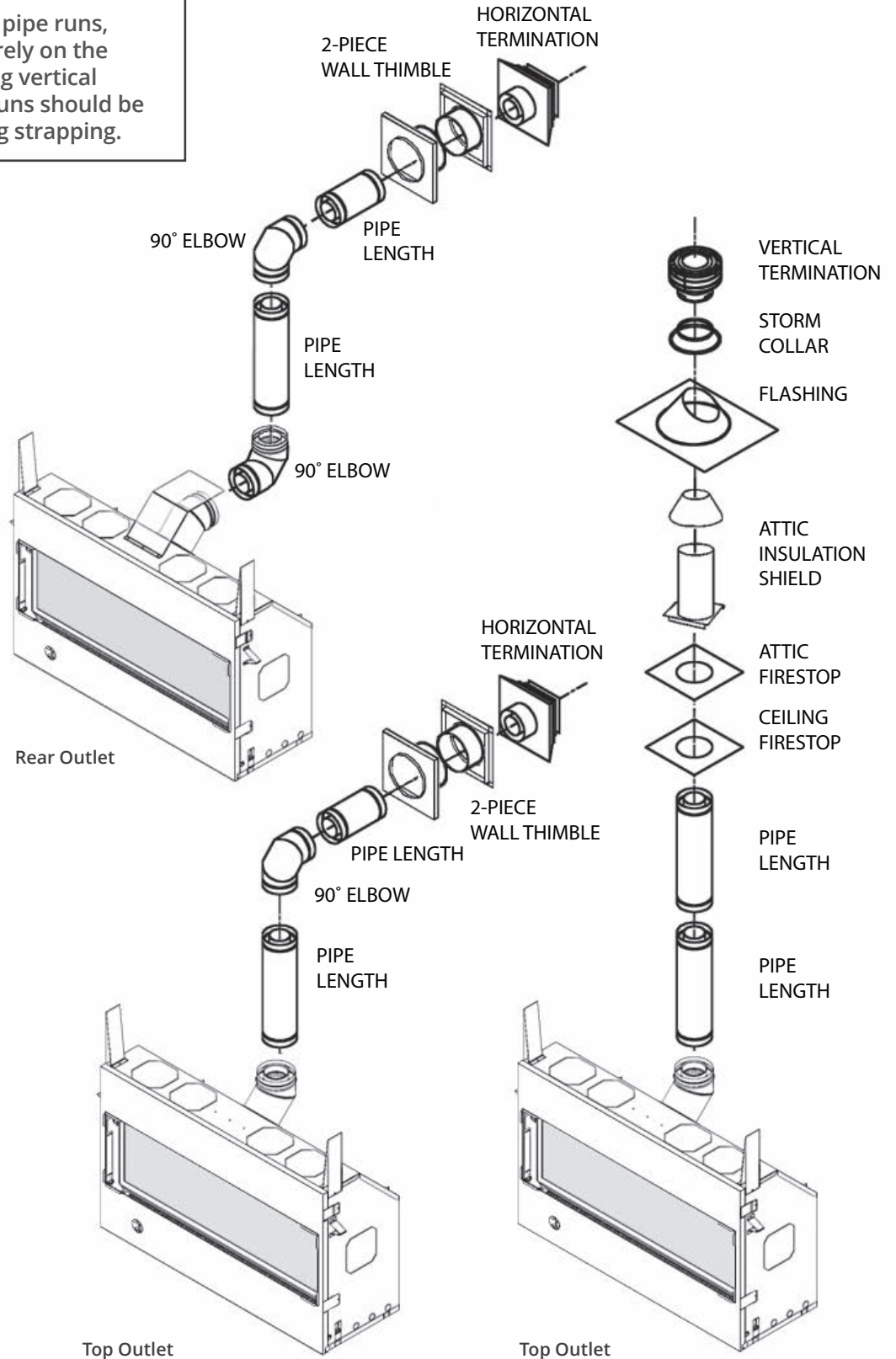

How to Read the Venting Chart

The chart below applies to co-axial roof or wall termination.

1. A minimum vertical rise of 24 inches is required directly off the unit or after first elbow, as shown.
2. The total length of the vent pipe cannot exceed 40 feet.
3. The minimum vertical height with roof termination is 6 feet.
4. Any combination of rise and run can be used as long as they are within the allowable limits shown on the chart below.
5. A maximum of 4 x 90 degrees elbows—or equivalent (2 x 45 degrees = 90 degrees)—can

be used. Excludes the 45 degrees take-off elbow shipped with the appliance.

6. Each 90 degrees elbow installed on the horizontal plane is equivalent to a 3 feet horizontal pipe; therefore, 3 feet must be subtracted from allowable horizontal run. (45 degrees elbow is equivalent to 18 inches horizontal pipe.)
7. All horizontal pipe runs must be graded 1/4 inch per foot upwards in the direction of the exhaust flow. The final pipe length, when terminating through the wall may be graded downwards slightly to prevent water migration.
8. A restrictor adjustment is required for most installations having a vertical rise—see “Restrictor Settings” on page 22.

Note: The restrictor is shipped installed at the exhaust exit of the firebox.

Venting Chart

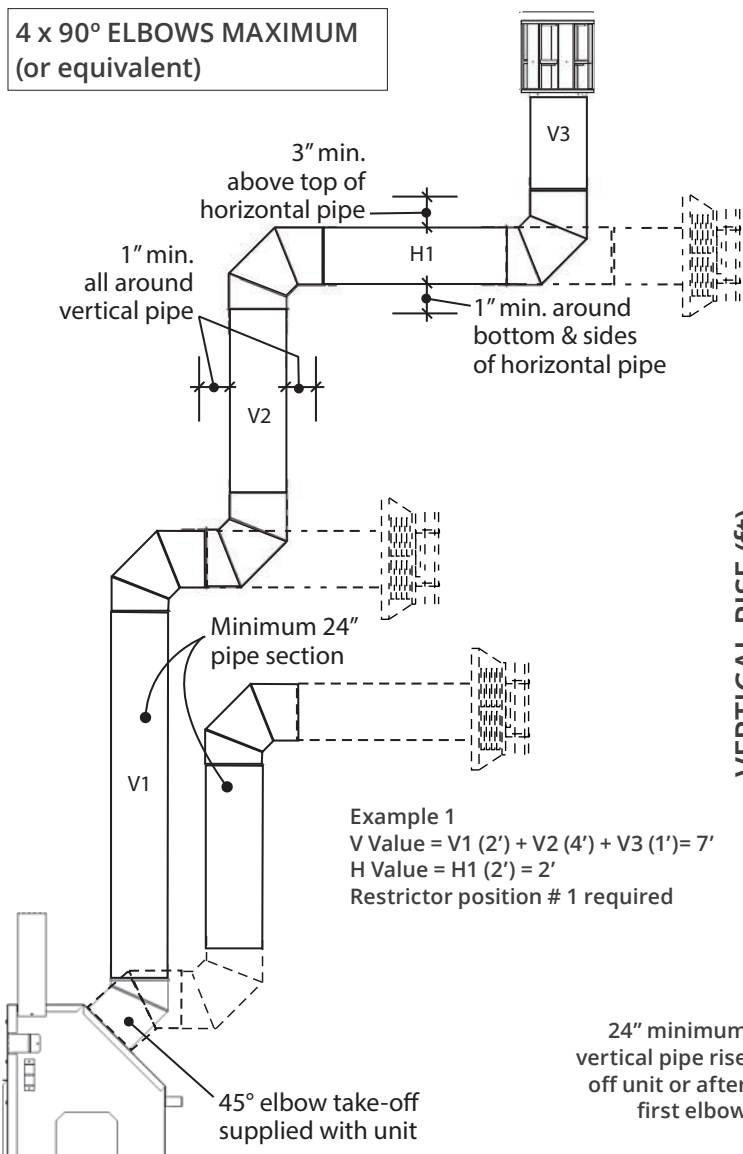

Allowable Co-Axial Vent Configurations with restrictor positions

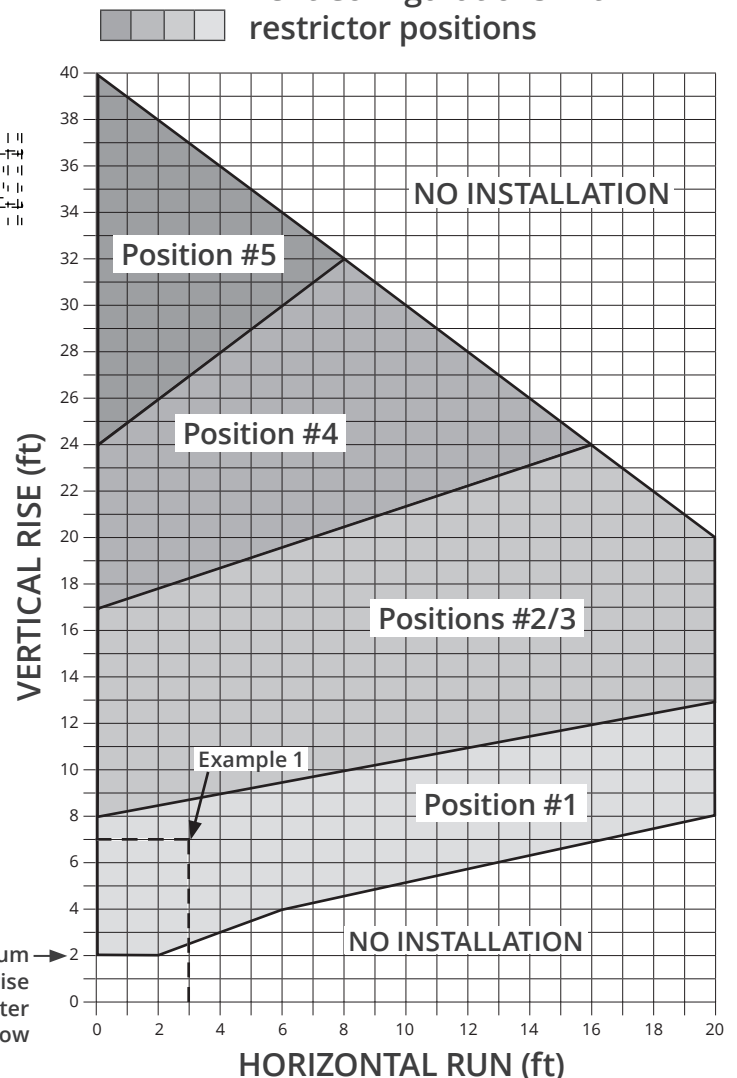

Restrictor Settings

The restrictor is located in the roof of the firebox hidden above the top liner panel. Adjust the restrictor before installation of the top liner panel. Should subsequent adjustment be required, you will need to remove the top liner panel—see “Liners” on page 39.

ALL INSTALLATIONS REQUIRE A RESTRICTOR for improved flame picture and performance. This unit is supplied with a pre-fitted restrictor having five different positions or settings. The restrictor is shipped mounted at the maximum open position which is used for rear venting with no vertical rise. The level of restriction required depends on the vertical rise in the venting system and, to a lesser degree, the horizontal run and number of elbows.

The amount of restriction is based on laboratory tests. The ideal restrictor position may vary slightly, especially when the vent pipe length is near the limits of the acceptable configurations for each type of restrictor.

The chart on the previous page shows the vent restrictor required relative to the length of the vent pipe.

To set the restrictor position:

1. Establish the required position of the restrictor looking up the venting table on the previous page.
2. Release the screws (2) on each side of the restrictor already installed **on the firebox roof port**.
3. Slide the restrictor in the required position.
4. Tighten the screws.

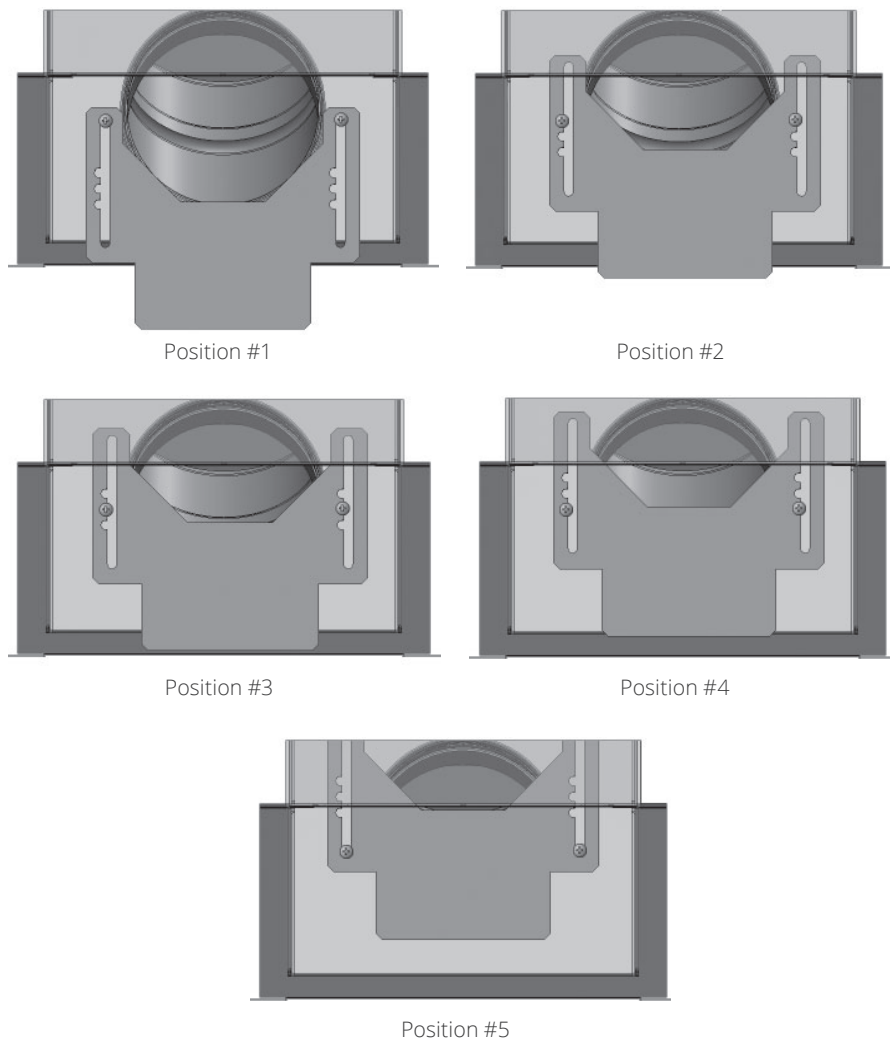
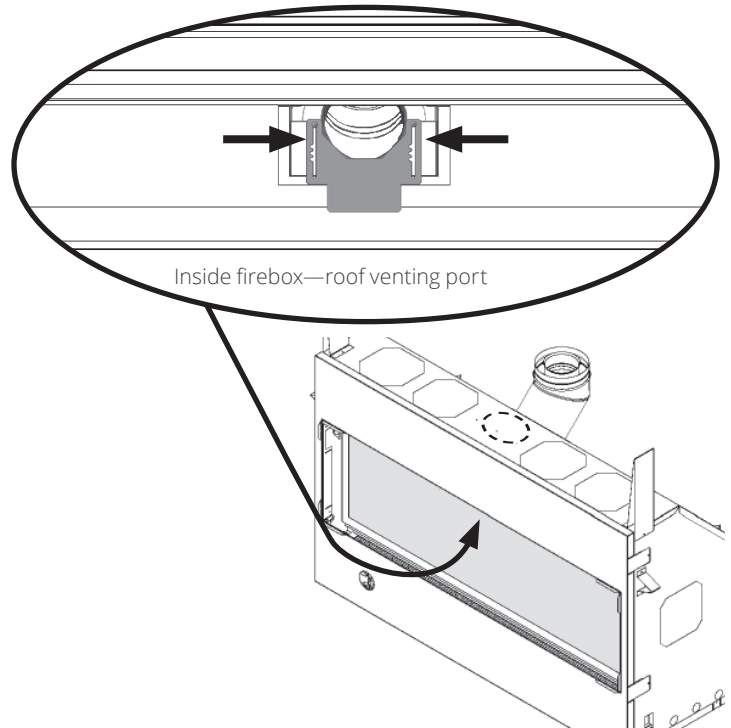

Horizontal Vent Termination Location

- The vent terminal must be located on an outside wall or through the roof.
- This direct vent appliance is designed to operate when an undisturbed airflow hits the outside vent terminal from any direction.
- The minimum clearances from this terminal that must be maintained when located on an outside wall are shown in figure below. Any reduction in these clearances could result in a disruption of the

airflow or a safety hazard. Local codes or regulations may require greater clearances.

- The vent terminal must not be recessed into a wall or siding.
- The vent terminal should be positioned where any snowdrifts will not cover it.
- Sidewall vent terminations require a terminal guard such as 658TG or 845TG when accessible—within 7' of ground.

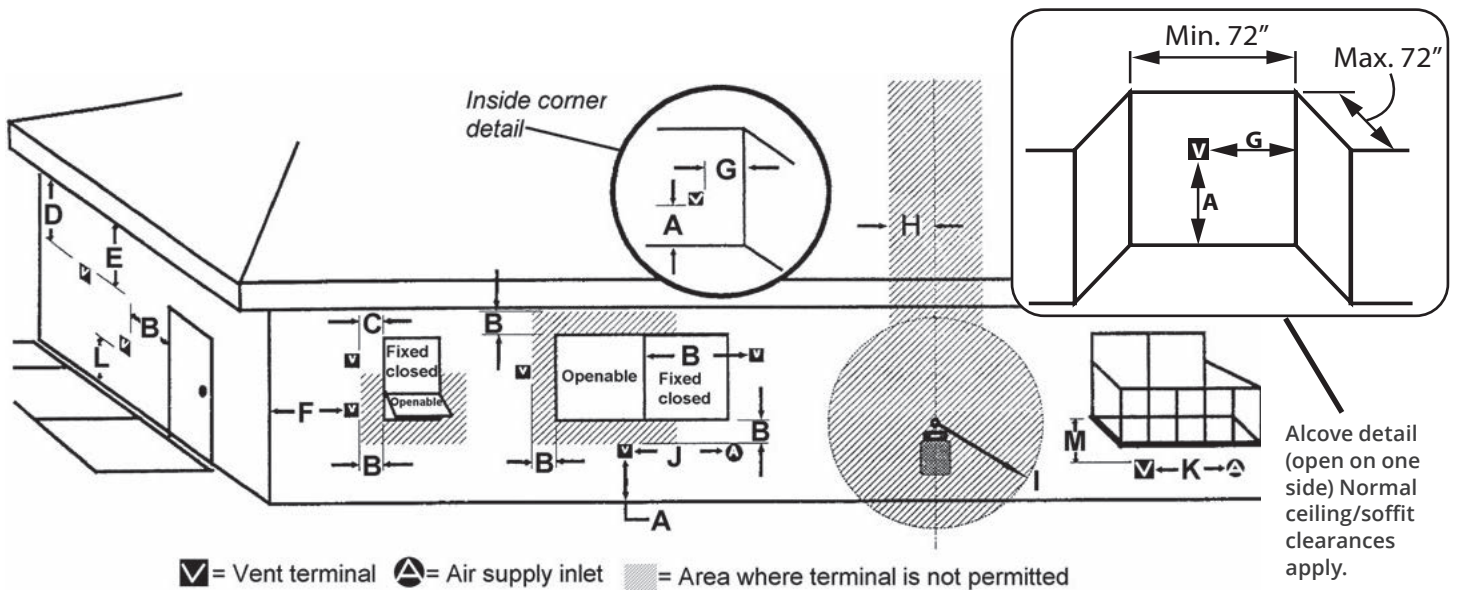

KEY	VENT TERMINAL LOCATIONS - MINIMUM DISTANCES	MINIMUM CLEARANCE	
		Inches	Cm
A	Clearance above grade, verandah, porch, deck or balcony	12	30
B	Clearance to window or door that may be opened	12	30
C	Clearance to permanently closed window (recommended to prevent condensation on window)	12	30
D	Vertical clearance to ventilated soffit located above the terminal within a horizontal distance of 2 feet (60 cm) from the center-line of the terminal	18	46
E	Clearance to unventilated soffit	12	30
F	Clearance to outside corner (measured from the center of vent)	12	30
G	Clearance to inside corner (measured from the center of vent)	12	30
H	Horizontal clearance to center-line of meter/regulator assembly located within 15 feet (4.6 m) below the terminal	36	90
I	Clearance to service regulator vent outlet	36	90
J	Clearance to non-mechanical air supply inlet to the building or the combustion air inlet to any other appliance	12	30
K	Clearance to a mechanical air supply inlet	72	180
L	Clearance above paved sidewalk or a paved driveway located on public property Note: A vent must not terminate directly above a sidewalk or paved driveway, which is located between two single-family dwellings and serves both dwellings. THIS DOES NOT APPLY to direct vent, non-condensing appliances in the Province of Ontario.	84	210
M	Clearance under a verandah, porch, deck or balcony Only permitted if veranda, porch, deck or balcony is fully open on a minimum of 2 sides beneath the floor	12	30

Note: Local codes and regulations may require different clearances.

Vertical Vent Termination

Roof Pitch	Minimum "H" (feet)
Flat to 7/12	1'
Over 7/12 to 8/12	1.5'
Over 8/12 to 9/12	2'
Over 9/12 to 10/12	2.5'
Over 10/12 to 11/12	3.25'
Over 11/12 to 12/12	4'
Over 12/12 to 14/12	5'

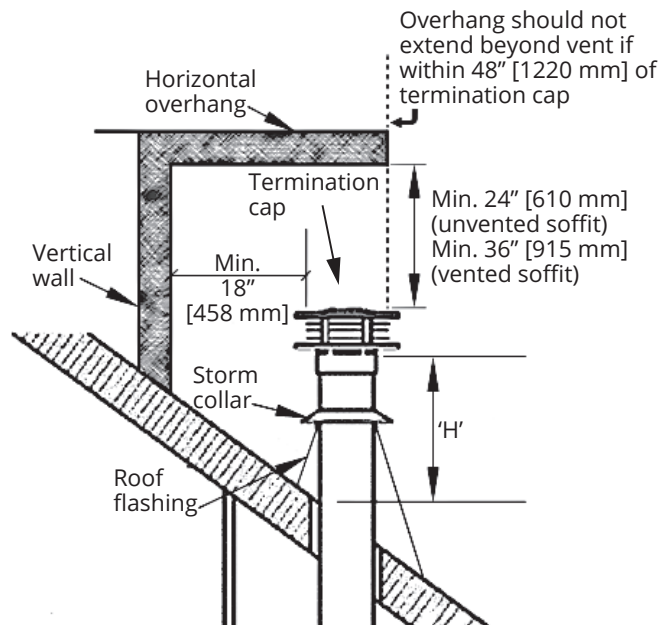

Venting

Co-Linear Conversion

Applications

This appliance can be converted to install as a co-linear application. The co-linear or co-axial flex portion of the vent system may only be installed within a solid-fuel burning appliance.

This appliance must not be connected to a chimney flue serving a separate solid-fuel burning appliance.

Types of Installations

- Complete installation into an existing fireplace
- Partial installation into an existing fireplace
- Installation into an adjacent chimney

See the following pages for each installation details.

Rules for Co-Linear Venting

- Maximum 40 feet vertical pipe
- Minimum 10 feet vertical
- Maximum offset 8 feet with liners at minimum 45 degrees from horizontal plane
- Restrictor: Not required when using co-linear venting.

NOTE

Co-linear or co-axial flexible aluminum venting liners should be professionally inspected periodically for corrosion and damage and replaced when necessary. If the installation does not allow for future inspection or replacement of the flexible aluminum liners, then stainless steel vent liners are recommended.

Existing Fireplace Preparation

A few points must be considered before inserting the L2 into an existing fireplace cavity. Generally, no modifications are allowed to the existing fireplace that will compromise the integrity of the existing fireplace.

Cutting away any sheet metal parts of the existing fireplace to accommodate the installation of the L2 is prohibited. Check with local authorities if in doubt.

Components that are bolted or screwed on such as dampers or baffles may be removed to accommodate the installation of the L2 engine. Refractory bricks, glass doors, screen rails, screen mesh, and log grates can be also removed.

Clean Fireplace and Chimney

Have the chimney swept and the fireplace cavity including ash dumps and clean-outs cleaned before installing the L2 heater and vent liners. Any creosote or soot residue remaining in the fireplace cavity chimney or clean-out may cause odors or stains once the L2 insert is installed. Consult with chimney sweep for information on how best to clean.

Existing Dampers

Factory-built, zero-clearance fireplaces will require the damper to be removed in order to install the vent liners. These dampers are usually bolted into place. Dampers in masonry fireplaces must be fixed open and may remain in place.

Ash Retaining Curbs

Some fireplaces (particularly factory-built) have a raised curb at the front edge to retain ashes. Check the dimensions carefully to ensure the L2 engine will fit behind any raised curb (some curbs may be removed separately from the refractory base).

Gas Line Routing

Plan the routing of the gas line before proceeding. Utilize the existing hole for the gas line of the factory-built fireplace.

If the fireplace has no access hole, carefully drill an access hole of 1.5 inch (37.5 mm) or less through the lower sides or bottom of the firebox in a proper workmanship manner. This access hole must be plugged with non-combustible insulation after the gas supply line has been installed.

See *Dimensions* section for detailed location of gas inlet. Also, take into consideration whether or not a fan or shut-off valve will interfere when planning routing of the gas line.

Combustible Mantels

Combustible mantel clearances must conform to those required for the original solid-fuel fireplace into which the L2 is being installed.

Attach Warning Conversion Plate to Existing Fireplace

(Label supplied with vent adapter)

Attach the "This fireplace has been converted..." label to the existing fireplace using screws or other mechanical means and store any removed parts in back of the existing fireplace for future use.

Venting

Co-Linear Conversion

Complete installation into fireplace cavity

The appliance can be installed completely inserted into the non-combustible cavity as illustrated. In this case, the firebox zero clearance standoffs supplied with the heater are not required. The appliance must not be connected to a chimney flue serving a separate solid-fuel burning appliance.

Required venting components:

- Valor Co-axial to co-linear adapter 1156CLA;
- 2 lengths of 2-ply, flexible chimney liner approved for venting gas appliances:
 - 1 x 3-inch diameter for air inlet and
 - 1 x 4-inch diameter for exhaust;
- Co-linear termination kit 3 x 4 and flashing or co-linear to co-axial adapter and either high wind vertical vent terminal cap or a low profile vertical termination.

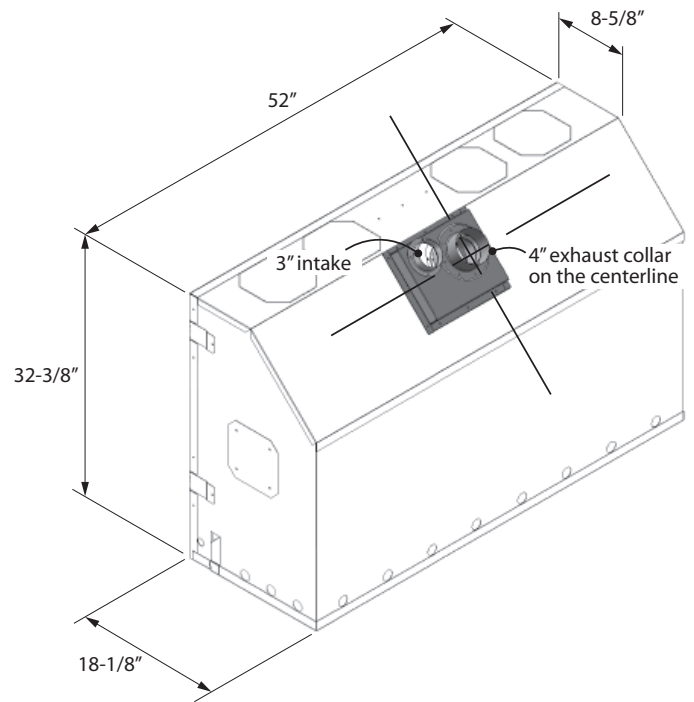

Dimensions with 1156CLA Co-Linear Adapter

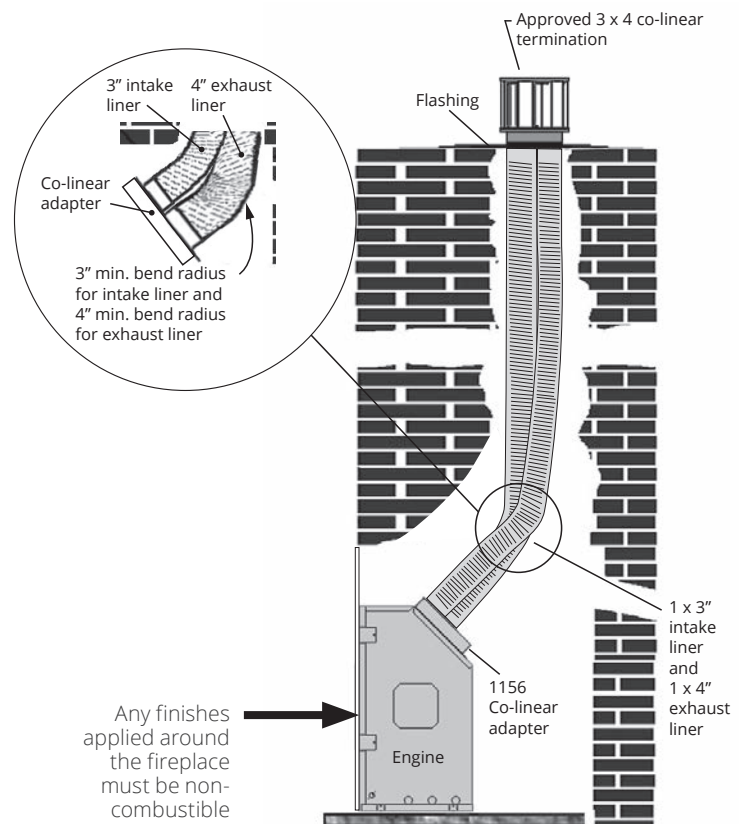
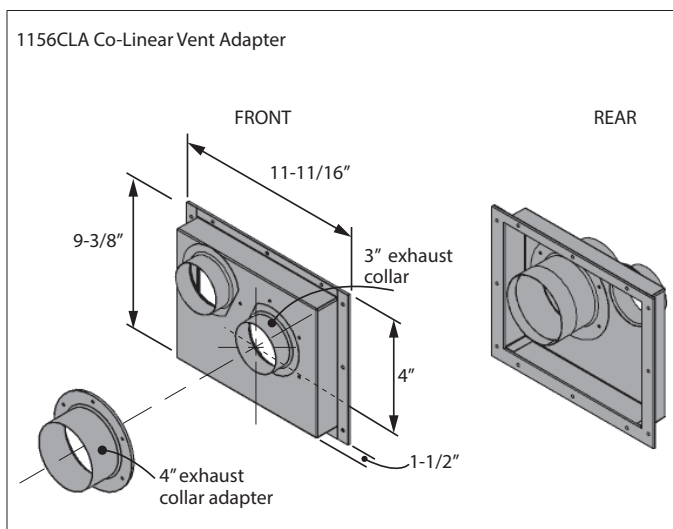

Co-Linear installation into existing fireplace

NOTE

See 1156CLA installation manual for complete instructions.

Venting

Co-Linear Conversion

Partial Installation Into an Existing Fireplace

The appliance can be partially inserted into the non-combustible cavity as illustrated below.

In this case, the appliance must be completely framed and maintain clearances to combustibles as shown in this manual.

Required venting components:

- Co-axial to co-linear adapter at appliance Valor 1156CLA, 46DVA-GCL34 or equivalent;
- 2 lengths of 2-ply, flexible chimney liner approved for venting gas appliances:
 - 1 x 3-inch diameter for air inlet and
 - 1 x 4-inch diameter for exhaust;
- Co-linear termination kit 3 x 4 and flashing or co-linear to co-axial adapter and either high wind vertical vent terminal cap or a low profile vertical termination.

NOTE

Standoffs are required to maintain clearances to combustibles for the part of the appliance outside a non-combustible cavity.

NOTE

This appliance must be completely framed and maintain clearances to combustibles as shown in this manual.

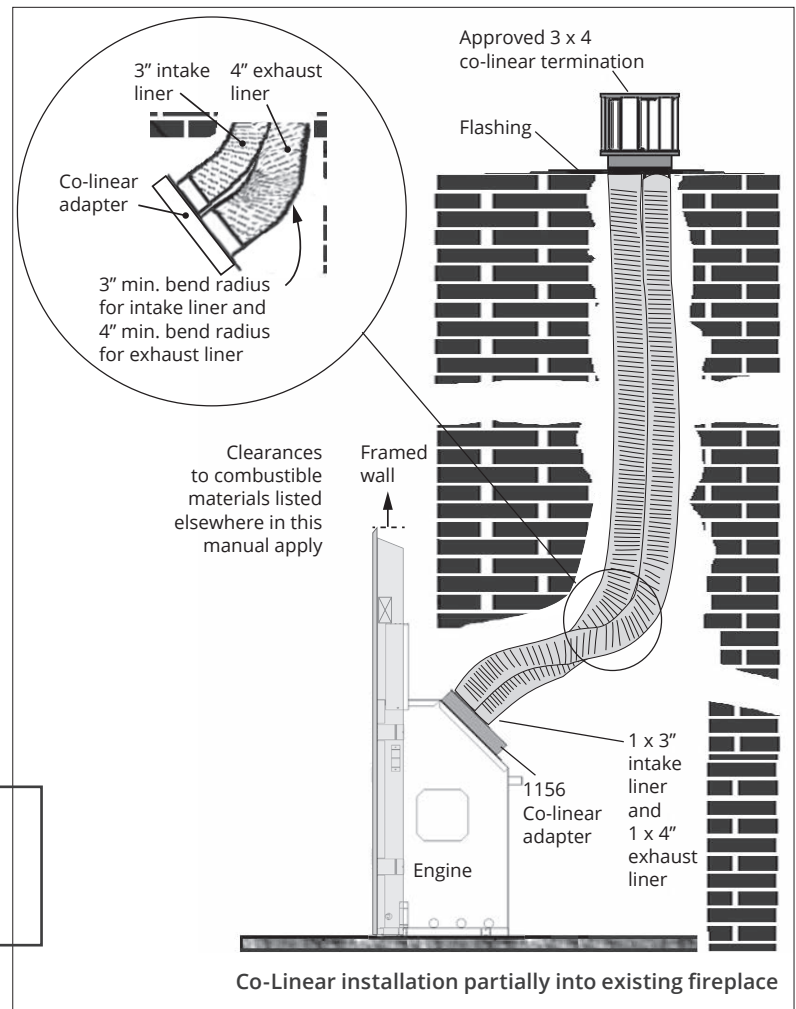

NOTE

See 1156CLA installation manual for complete instructions.

Venting

Co-Linear Conversion

Installation Into an Adjacent Chimney

The appliance's venting system can be partially inserted into the non-combustible adjacent chimney as illustrated below.

In this case, the appliance must be completely framed and maintain clearances to combustibles as shown in this manual.

Required venting components:

- Co-axial to co-linear adapter at appliance 46DVA-34CLAA, 46DVA-GCL34 or equivalent;
- 2 lengths of 2-ply, flexible chimney liner approved for venting gas appliances:
 - 1 x 3-inch diameter for air inlet and
 - 1 x 4-inch diameter for exhaust;
- Co-linear termination kit 3 x 4 and flashing or co-linear to co-axial adapter and either high wind vertical vent terminal cap or a low profile vertical termination.

NOTE

Standoffs are required to maintain clearances to combustibles for the part of the appliance outside a non-combustible cavity.

NOTE

This appliance must be completely framed and maintain clearances to combustibles as shown in this manual.

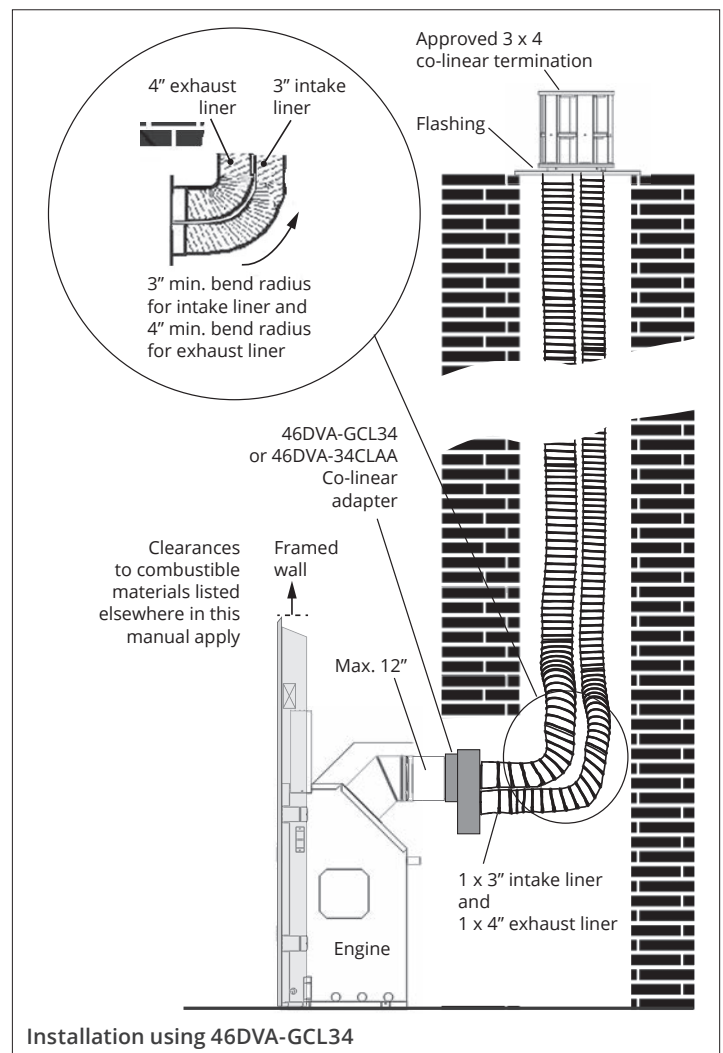
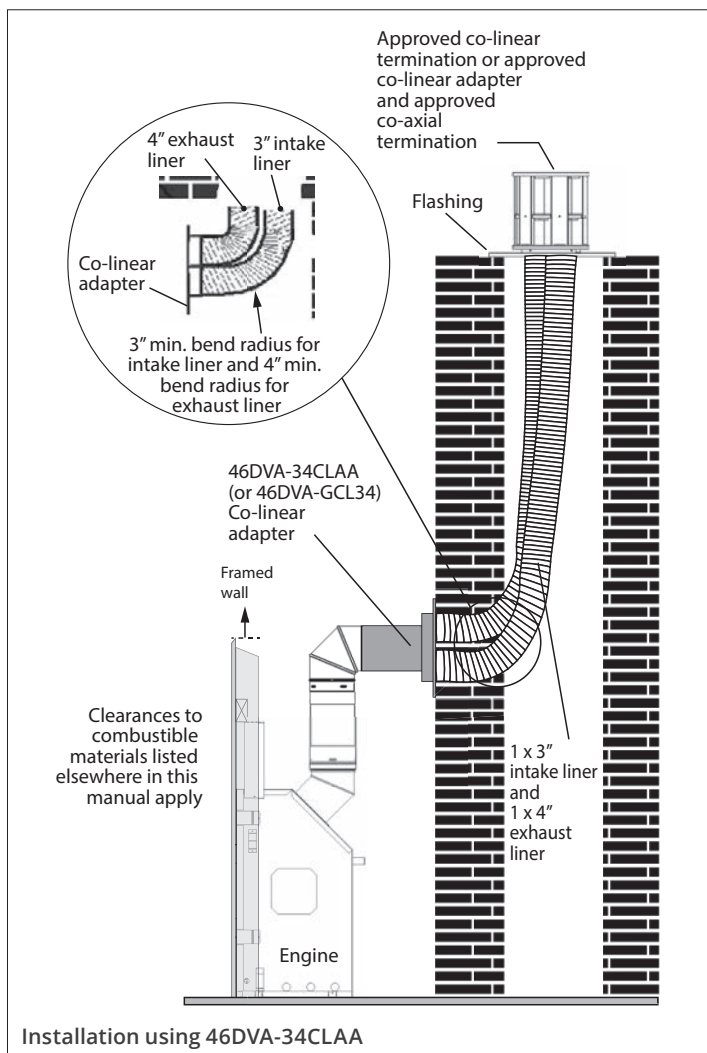

Venting

Co-Linear Conversion

Example of co-linear conversion accessories

Examples of Co-axial to Co-linear Appliance Adapters



46DVA-GCL34



46DVA-34CLAA

Examples of Co-linear Terminal Configurations

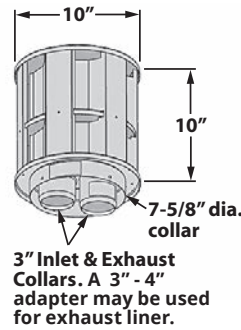

Co-Linear Terminal (typical)

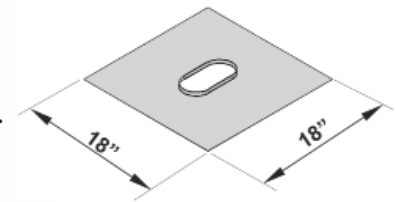

Flashing Kit

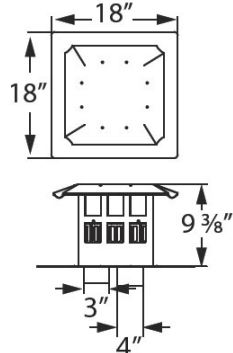
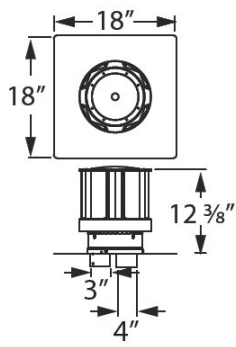

Co-linear Termination Kits

Alternate Co-linear to Co-axial Conversion at Terminal

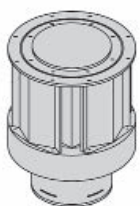

Co-axial Terminal Cap

With...

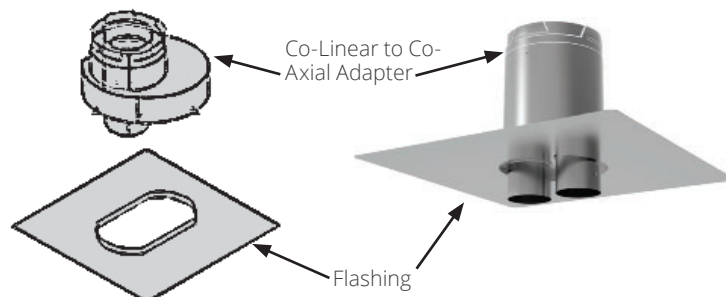

Installation

Appliance Preparation

Unpack Appliance

Beware of sharp edges! Wear gloves!

1. Remove the cardboard wrapping and the wood pallet from the appliance and discard.
2. Unpack any loose items from around the appliance.
3. Remove the window and set aside in a safe place to avoid damage—see “Remove Window” on page 33.
4. **Verify that you have all the components required for the installation, including:**
 - approved cement board;
 - liners and fuel bed (in separate cartons);
 - trim kit with barrier screen;
 - venting components and accessories;
 - optional HeatShift system if used;
 - electrical components if installing optional fan or WiFi.

Fit Standoffs

The standoffs are supplied flat on the firebox sides and fixed at one end. Swivel up the flat standoffs, bend them as shown and fix the loose end to the top of the firebox.

Remove Heat Shield

Remove the heat shield from the top of the appliance case (3 screws). If using a rear outlet, keep the shield to reinstall after converting the top to rear outlet—see next subsection. If using the top outlet or the HeatShift system, discard the shield.

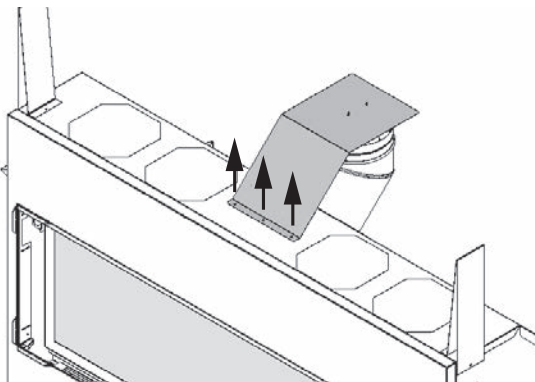

Remove heat shield (3 screws)

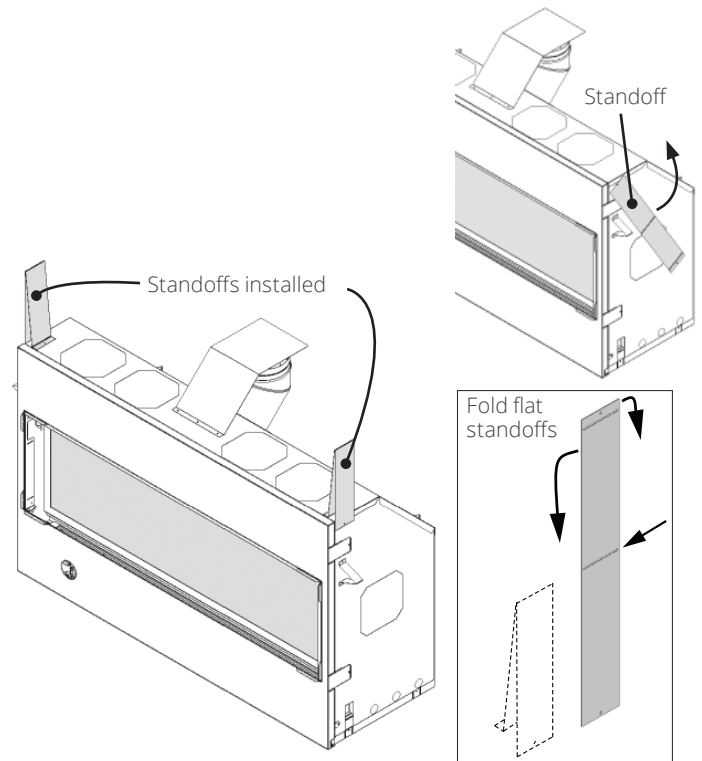

Installation

Appliance Preparation

Convert from Top to Rear Outlet (if required)

This unit is supplied with a top vent outlet which can be field-converted to a rear vent outlet.

Please note that the rear outlet requires the installation of the heat shield on top of the heater case as indicated.

1. Remove the top outlet collar (6 screws).
2. Swivel the collar and install as a rear outlet (6 screws).
3. Reinstall the heat shield to the top of the appliance case (3 screws).

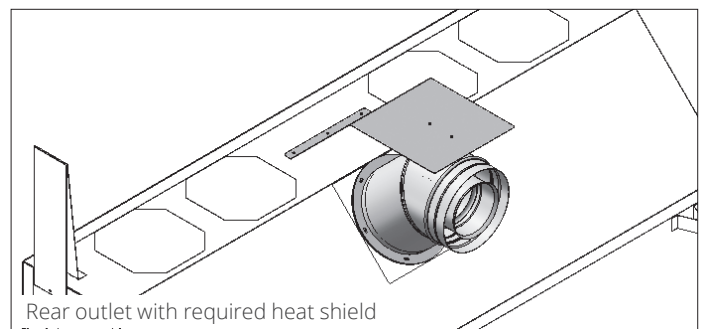
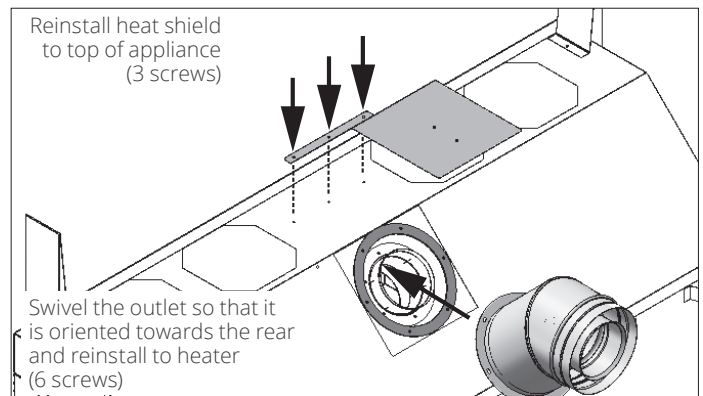
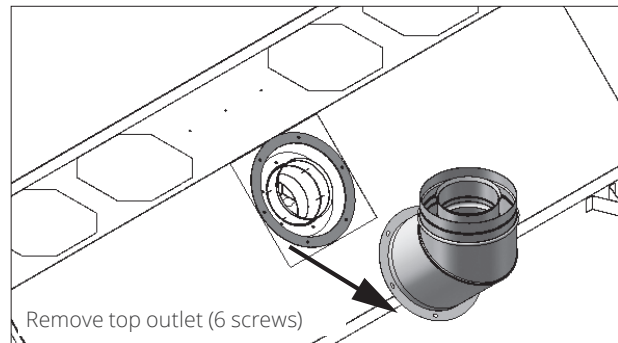

Installation

Appliance Preparation

Fit Appliance into Framing

1. Remove the 4 screws retaining the engine to its pallet.

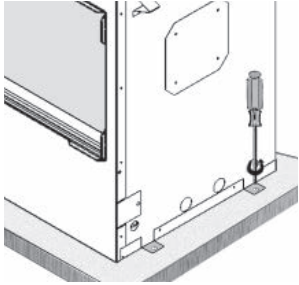

2. Taking great care not to cut your hands on the sheet metal edges, lift the appliance out of its packing base and place it in the framing. *Make sure that the unit is at the right height with consideration to the height of the hearth or combustible flooring.*
3. Fold out four mounting tabs and recess the appliance in the framing as shown.
4. Fasten the unit to framing using 4 screws or nails at the mounting tabs.

Note: The sheet metal front face of the appliance is flush with the framing studs.

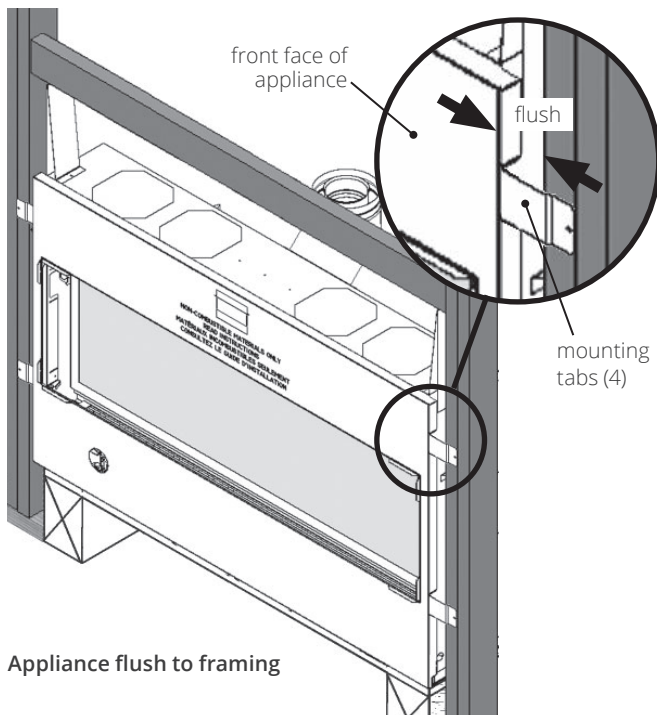

Installation

Appliance Preparation

Remove Window

The window is held in place by a spring-loaded lever on each side.

1. To remove the window, locate the levers on each side of the window towards the top. Using your finger, pull the lever towards you and unhook it from the window frame bracket.
2. Gently pull the top of the window outward.
3. Lift the window out of its bottom railing and set it aside in a safe place to avoid damage.

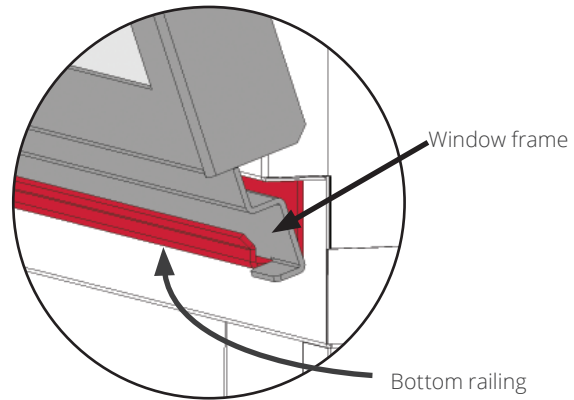

Section Views

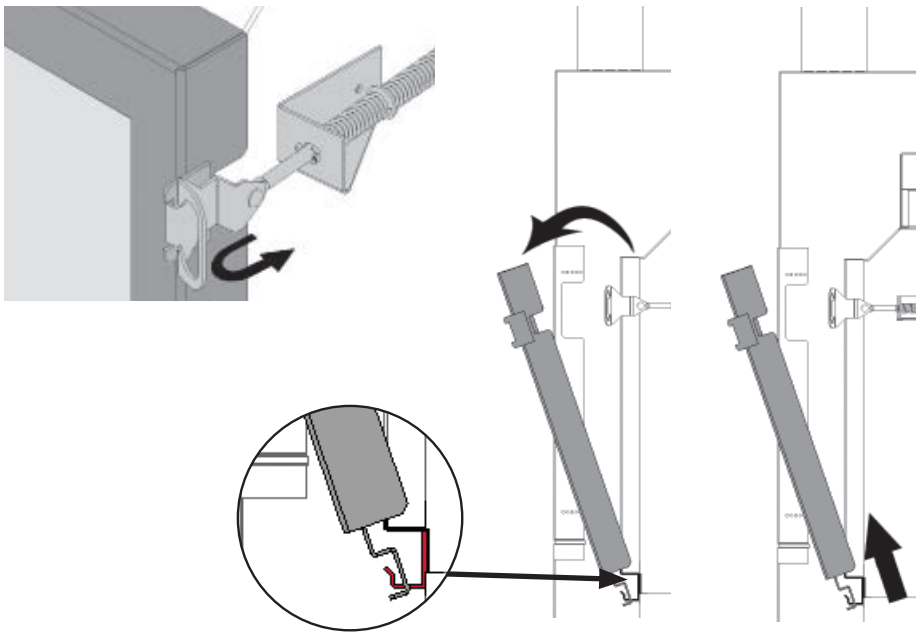

Installation

ONLY If You Are Installing HeatShift!

Perform the following steps and see “Appendix D—HeatShift System” on page 75 for more details regarding HeatShift planning and installation.

Remove Convection Baffle

To be effective, the HeatShift system requires that an internal convection baffle located above the firebox inside the appliance case be removed to allow the hot air flow to convect upwards into ducts installed on the fireplace.

Remove the convection baffle from the appliance. It is held in place by 3 screws located right behind the upper edge of the fireplace opening. Recycle this panel as it is no longer needed.

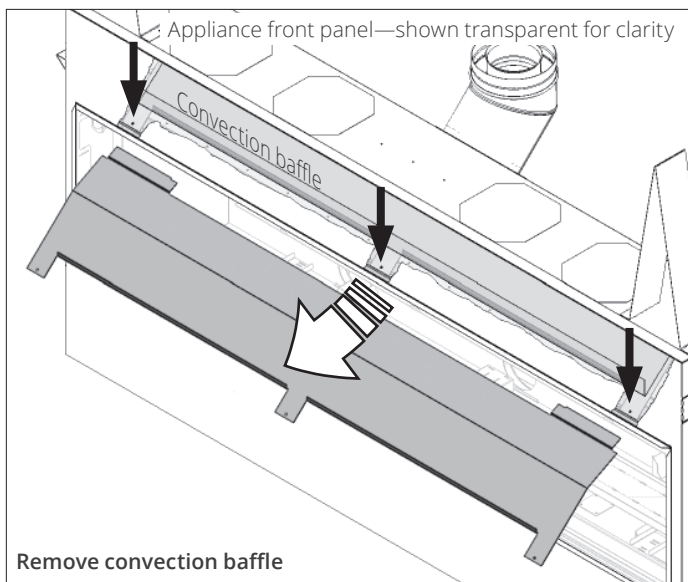

HeatShift™ System—if used

Install HeatShift Take-Off Collars to Appliance

1. Remove the four cover plates on top of the appliance case (6 screws each).

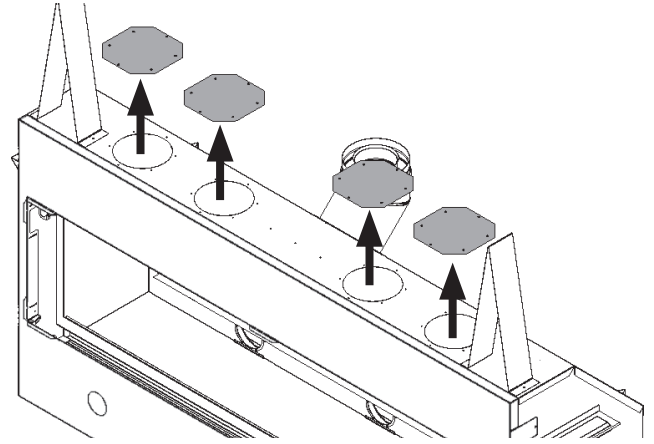

2. Install the take-off collars on the holes on top of the appliance's case (6 screws each).

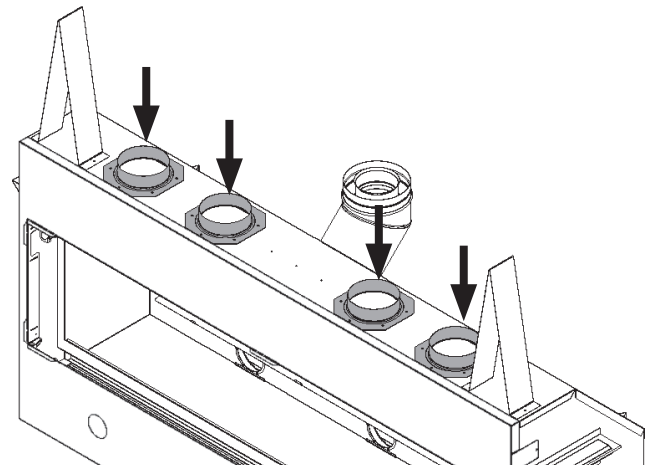

WARNING

The Linear fireplaces requires the removal of the internal convection baffle for the HeatShift system to function properly—read instructions carefully!

WARNING

All FOUR (4) takeoffs MUST BE CONNECTED TO PLENUM(S).

Installation

Electrical Wiring

Install Electrical Wiring (if required)

This section provides information to install the electric pre-wiring required for use with the optional 1595CFKV2 Circulating Fan Kit and/or the GV60WIFI WiFi Kit.

⚠ WARNING

All electrical installations must be performed by a qualified electrician and must be electrically wired and grounded in accordance with local codes or, in the absence of local codes, with the National Electrical Code, ANSI/NFPA 70 or the Canadian Electrical Code, CSA C22.1.

⚠ WARNING

NO ELECTRICAL CONNECTION ALLOWED for any outdoor installation!

Electrical Requirements

1595CFK—120 VAC, 60 Hz, less than 1 amp

GV60WIFI—6 VDC (from receiver), less than 1 amp

General Requirements

Both optional 1595CFK and GV60WIFI kits require a GV60VM power supply (known as a V-Module), which includes a three-prong grounded plug to plug into a grounded receptacle installed within the fireplace enclosure by a qualified electrician.

The receptacle, housing, and strain relief are supplied and installed as part of the fireplace.

Notes

- We recommend connecting the electrical box even if the optional accessories have not been purchased. It is much easier to wire before wall finish is applied.
- Wiring within the receptacle enclosure must have a minimum 90°C temperature rating.
- Wire nuts not included.

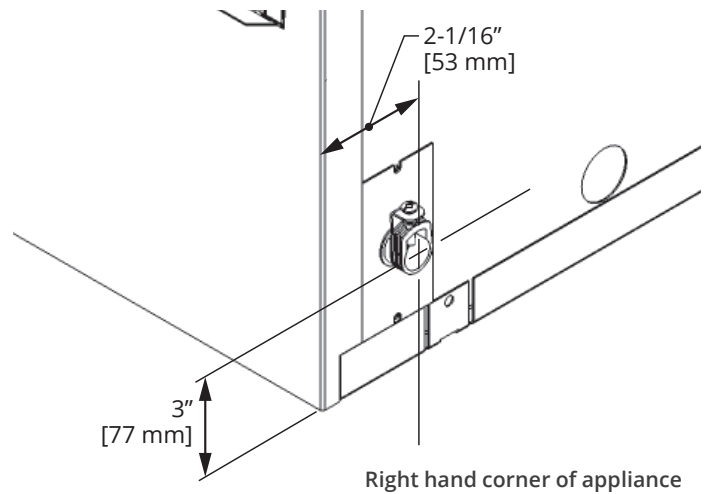

Installation

1. Locate the electrical housing. It is behind the front panel of the fireplace in the bottom right corner.

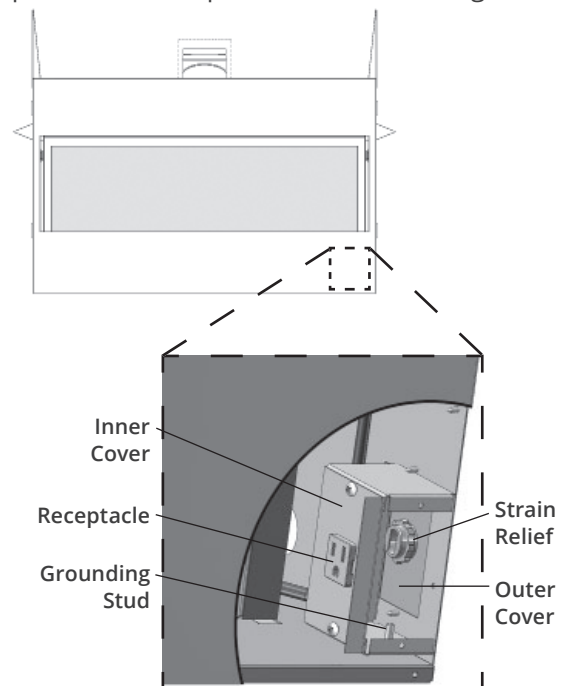

2. Remove the inner cover (2 screws).

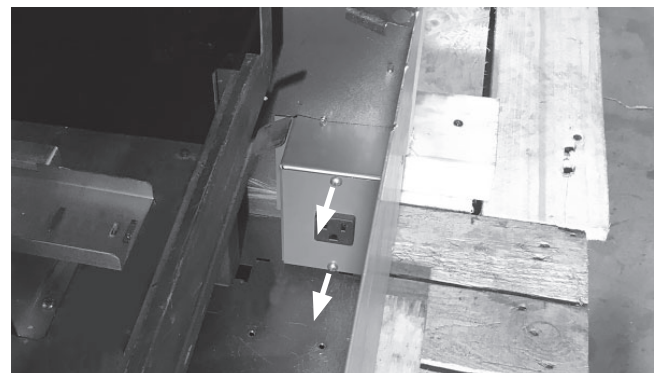

Installation

3. Pull the inner cover and receptacle (attached) out of the fireplace.

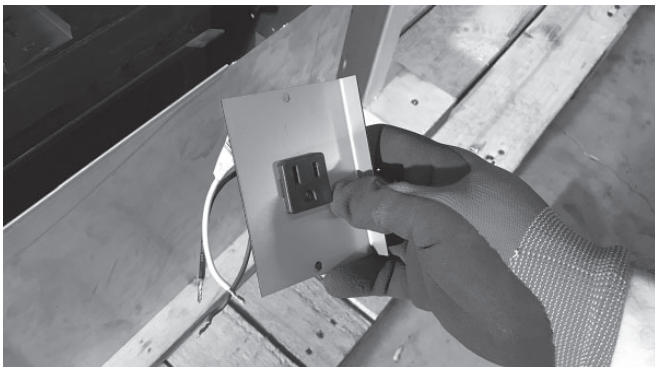

4. Thread the cable through the stud and the strain relief in the fireplace case. **Do not tighten the clamp yet.** Pull as much wire through the case as you need to wire the receptacle outside the case.



5. Strip wire and terminate grounded receptacle using wire nuts (not included). Place the connected receptacle back in the fireplace, and pull excess cable back through the strain relief.

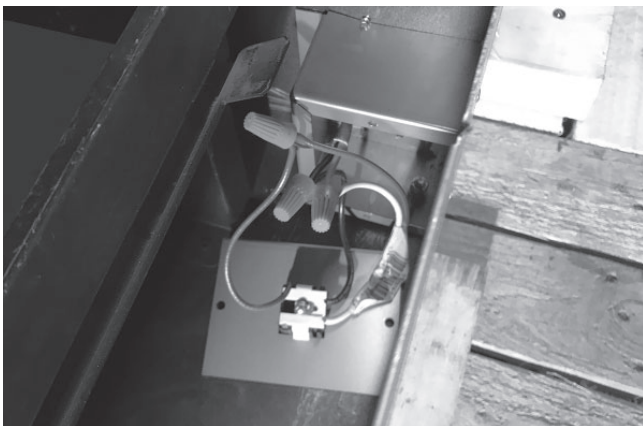

Electrical Wiring

6. Place the inner cover and receptacle in position and replace 2 screws.

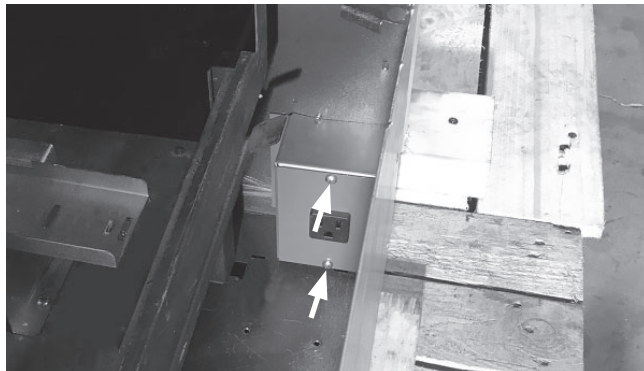

7. Leave your desired cable slack in the electrical box, and tighten the strain relief cable clamp outside of fireplace casing and secure excess wire to framing.

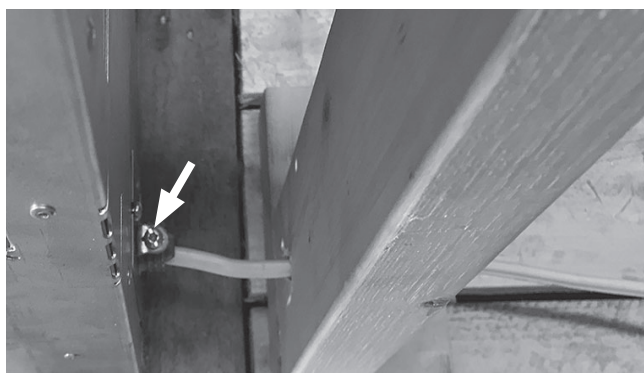

Installation

Gas Supply

Set-up Gas Supply

The gas supply inlet connection is a 3/8" NPT male connector located on the left hand side of the firebox.

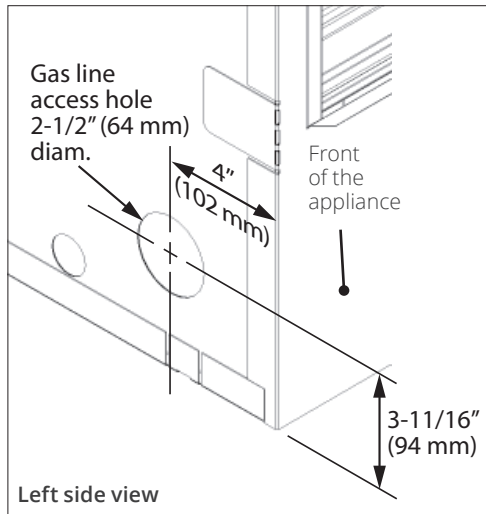
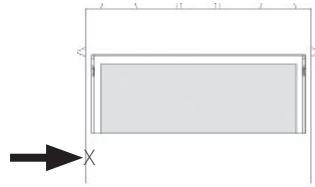

The unit is supplied with a stainless steel flex line to allow the appliance to be disconnected for service. An individual shut-off valve (not supplied) is required on the supply line ahead of the flex connector.

Use only new black iron or steel pipes, CSST, or copper tubing if acceptable—check local codes. Note that in USA, copper tubing must be internally tinned for protection against sulfur compounds.

Unions in gas lines should be of ground joint type.

The gas supply line must be sized and installed to provide a supply of gas sufficient to meet the maximum demand of the appliance without undue loss of pressure.

Sealant used must be resistant to the action of all gas constituents including LP gas. Sealant should be applied lightly to male threads to ensure excess sealant does not enter gas lines.

Pressure test the supply line for leaks.

The appliance and its individual shut-off valve must be disconnected from the gas supply piping system during any pressure testing of that system at test pressures in excess of 1/2 psig (3.5 kPa).

The appliance must be isolated from the gas supply piping system by closing its individual manual shut-off valve during any pressure testing of the gas supply piping system at test pressures equal to or less than 1/2 psig (3.5 kPa).

Failure to either disconnect or isolate the appliance during pressure testing may result in regulator or valve damages and void the warranty. Consult your dealer in case of damages.

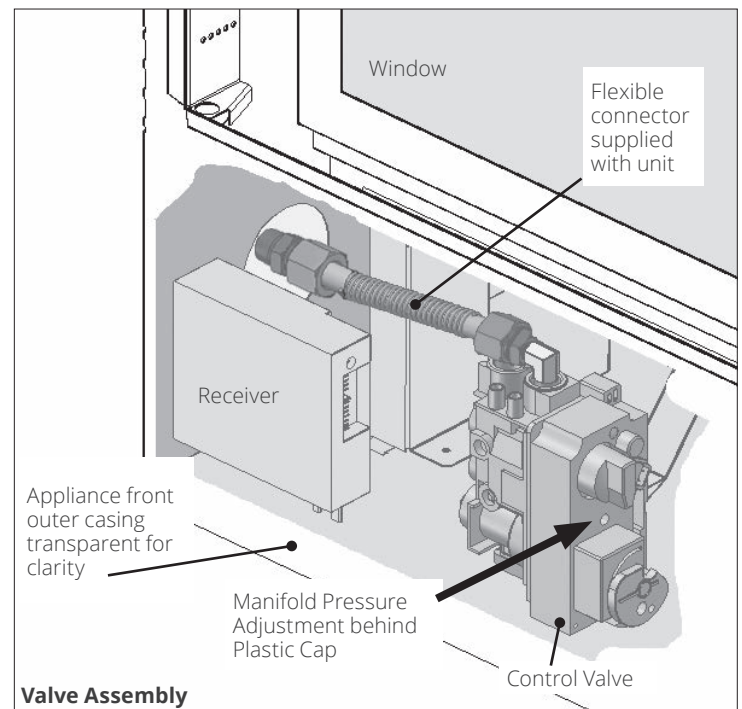

Installation

Gas Supply

Pressure Test Points

The minimum supply pressure is given in the section “Specifications” on page 6.

All piping and connections must be tested for leaks after installation or servicing. All leaks must be corrected immediately.

When testing for leaks:

- Make sure that the appliance is turned off.
- Open the manual shut-off valve.
- Test for leaks by applying a liquid detergent or soap solution to all joints. Bubbles forming indicate a gas leak.



Caution

Never use an open flame to check for leaks!
Correct any leak detected immediately.

The pressure test tapping locations are shown in the figure at right. An internal regulator within the valve controls the burner manifold pressure. The correct pressure range is shown in the table in section “Specifications” on page 6. The pressure check should be made with the burner alight and at its highest setting. See “Appendix A—Lighting Instructions” on page 66 for full operating details.

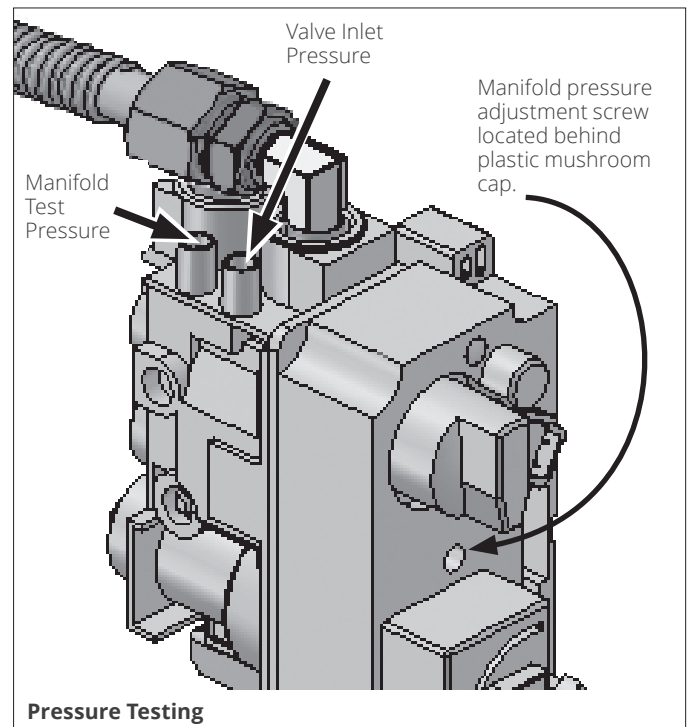

Installation

Liners

The liners install in the manner outlined below **with the exception of the 1725RGL Reflective Glass Liners**—see instructions supplied with the liners.

Unpack the liner panels carefully.

1. Inside the firebox, on the top of each side, release the screw of the side panel anchors (one per side) just enough to allow them to rotate.

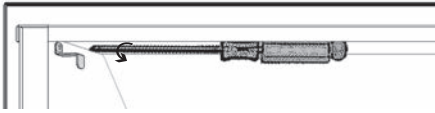

2. Place the right end panel against the right wall of the firebox. Place the bottom edge in first and carefully press the panel to the outside wall. Rotate the panel anchor and tighten its screw.

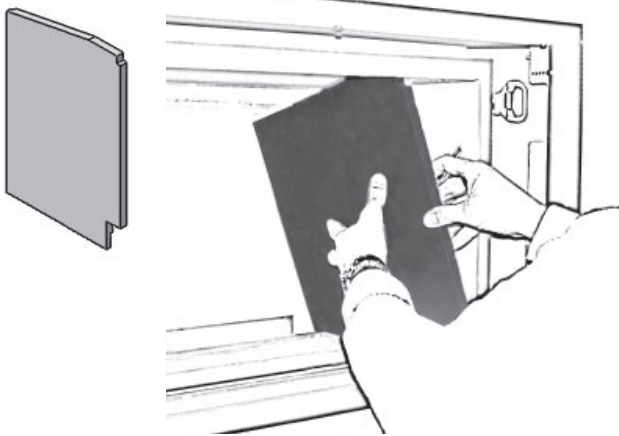

3. The rear panel is supplied in three sections which are fitted into each other. Two of the sections are identical. Their step edges go towards the middle to fit into the middle section.

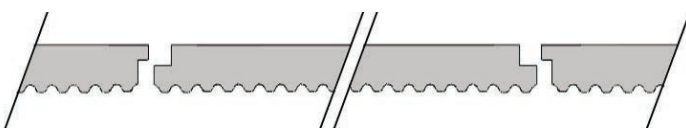
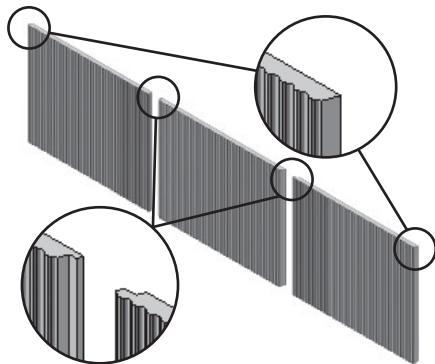

Rear panel sections—top view

Place the panel's right section on the ledge above the ports of the rear of the firebox. The section sits on the ledge behind the tabs, with its plain edge on right side; slide it behind the right side panel.

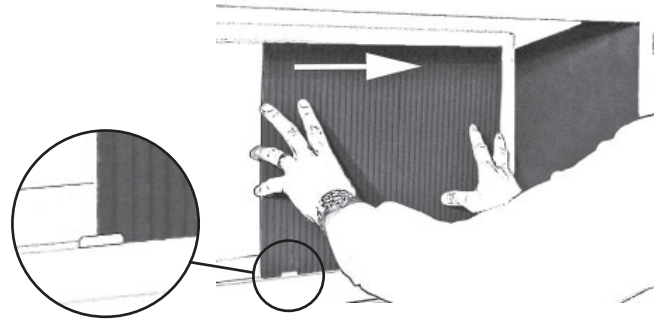

4. The top panel is supplied in two identical sections. The top of the panel is beveled and the 'fire side' is straight at the front and notched at the back. When installed, the panel rests on the top of the rear and side panels. In the front, it rests on the top panel support bracket located inside the front edge of the firebox.

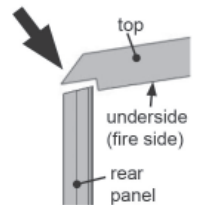

Position and slide top panel into corner.

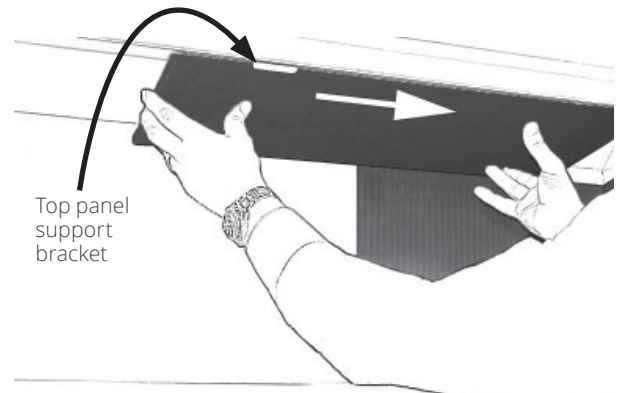

5. Carefully position, lift and slide second section of the top panel on top of the first.

Installation

Liners

6. Place rear panel's centre section on the ledge behind the tabs, slide it to the right so that its stepped edge fits into the stepped edge of the rear panel's right section.

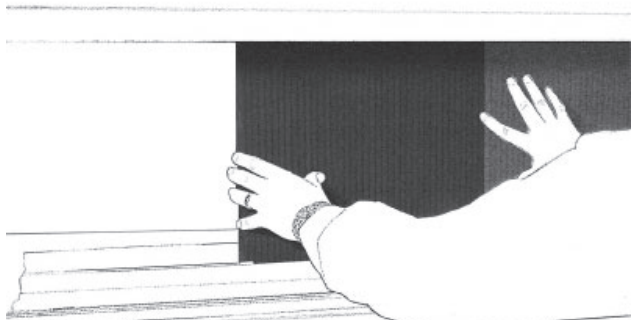

7. Place the left side panel against the left wall of the firebox. Rotate the panel anchor and tighten its screw.

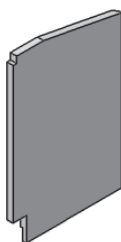

8. Place the remaining rear panel's section behind the left side panel and fit its stepped edge to the stepped edge of the rear panel's center section.

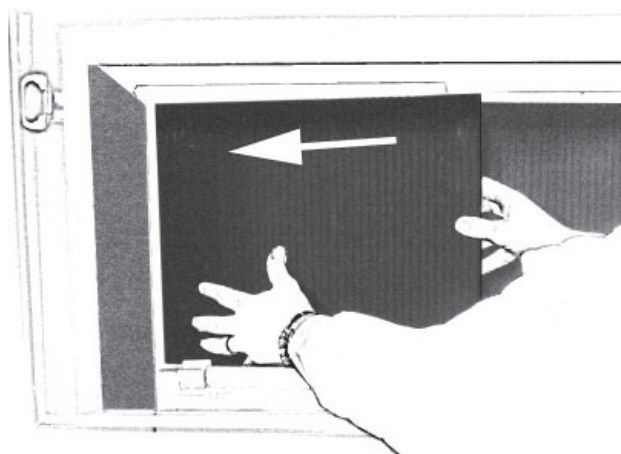

9. Carefully lift, slide and position top panel on to left side and rear panel.

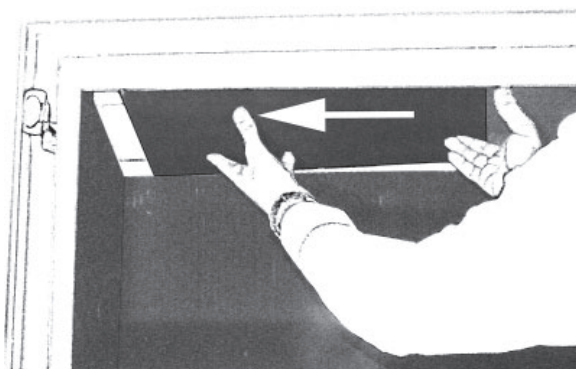

NOTE: If gapping occurs between each section of the rear panel, a lift tab located on each end of ledge can be bent by hand to close the gap.

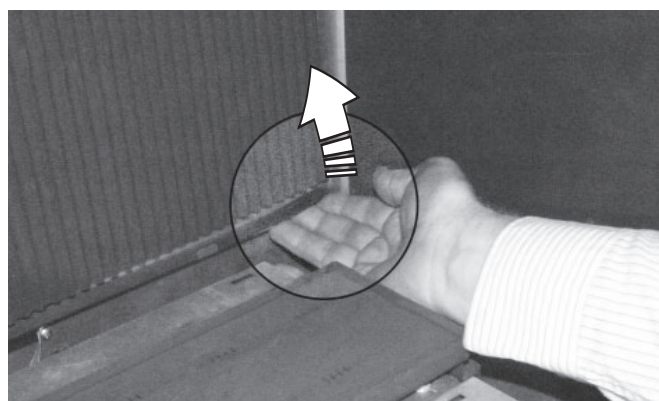

Installation

Fuel Beds

Driftwood Kit 1705DWKV2

Material required

- Black steel platform (supplied with appliance)
- Driftwood Kit containing:
 - 7 logs
 - 6 pebbles
 - 1 bag of vermiculite

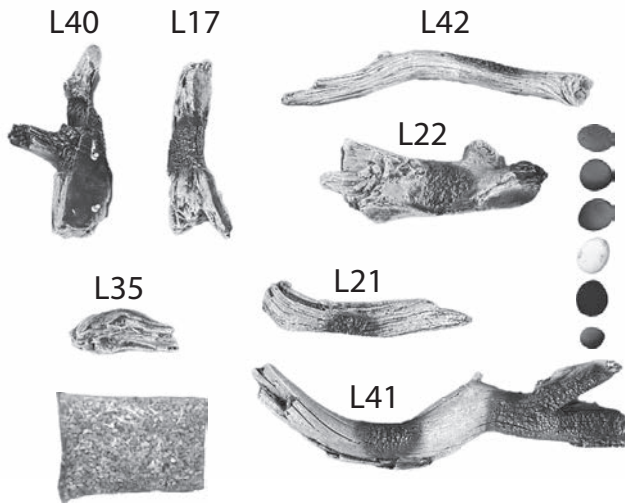

NOTE

Use of this log set may increase the possibility of soot formation when air shutters are set to the minimum setting. Although L2 fireplaces are fitted with a minimum air shutter stopper intended to prevent sooting with most log sets, it is possible some sooting may occur when using this log set and the air shutter is set to minimum position.

Evaluate the flame picture carefully after the unit has warmed up for fifteen minutes, and avoid setting the air shutter to minimum when there is limited rise in the venting system or the flame appears overly luminous and lazy with smoke trailing off the flame tips.

Refer to "Checking Operation and Aeration" on page 59 of this manual for more information.

L2 Installation

1. Carefully unpack the kit, as the logs are fragile.
2. Install the steel platform around the burner as indicated. The openings in the platform should be underneath.

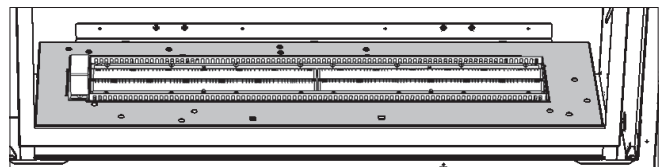
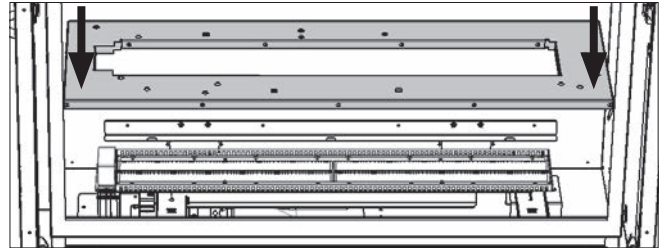

Installed platform

3. Place log L40 with its two pins in the two available holes at the left end of the rear platform.

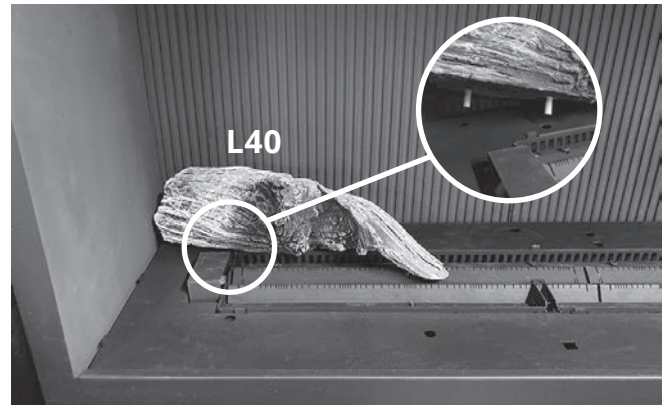

4. Place log L22 at the right end of the burner. There is a cutout that fits over the right rear corner of the burner - the log should be placed 1/8" away from the burner, not directly against it.

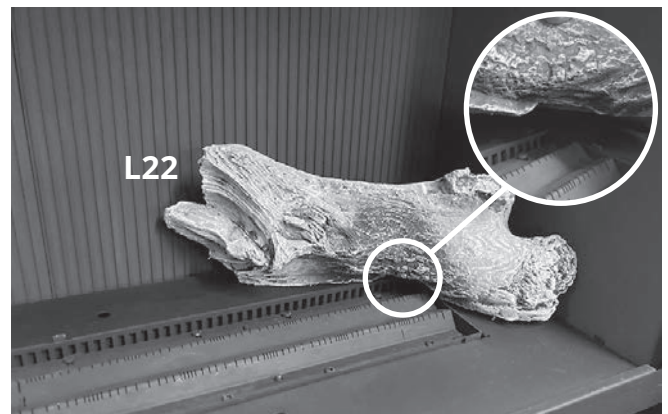

Installation

Fuel Beds

5. Place log L41 with the pin in the hole as shown on the rear platform.

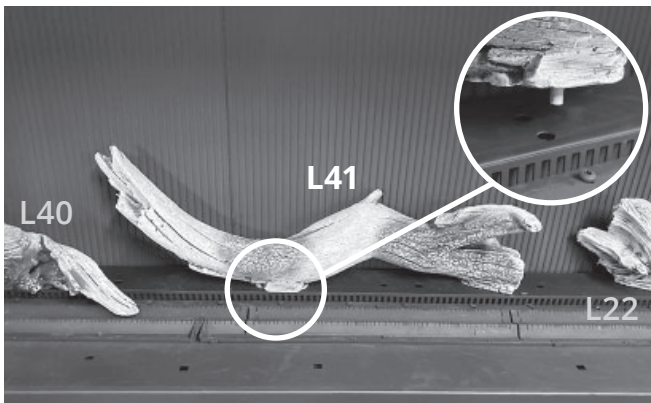

6. Place log L17 as shown, from the top of the pilot shield to the front platform.

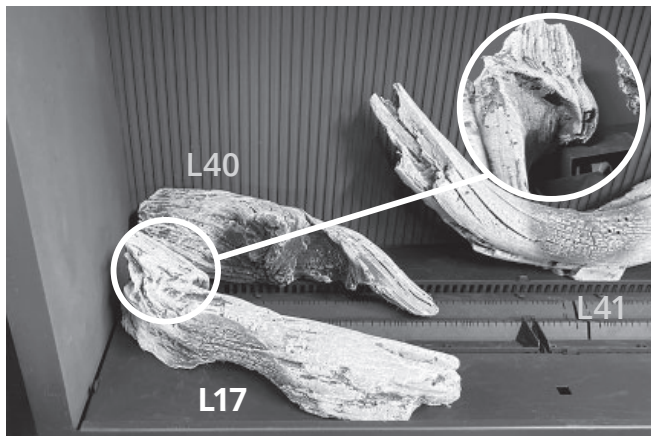

7. Place log L42 from the front side of the platform onto the groove in log L41 as shown.

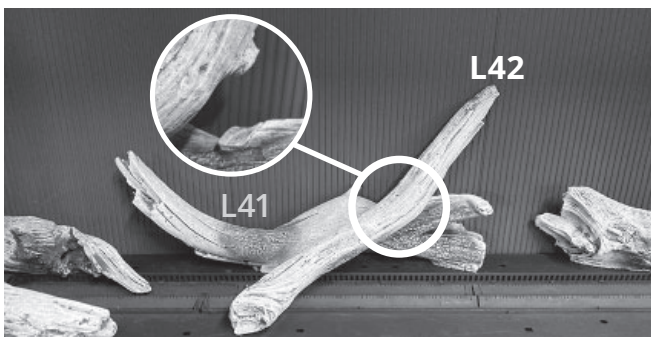

8. Place log L35 on the front of the platform as shown (it should not rest on the burner's edge).

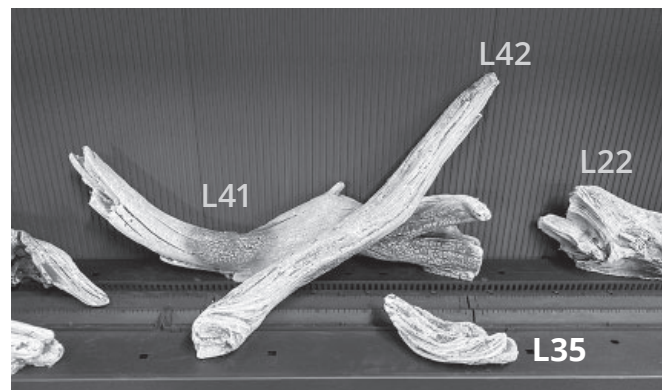

9. Place log L21 in the natural groove on top of L22. Place the other end on the front platform.

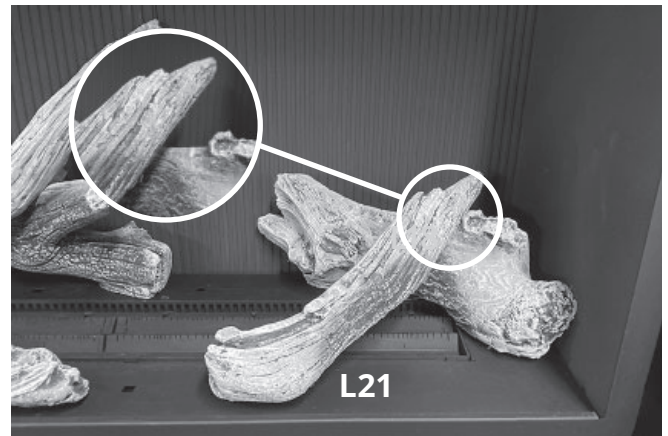

10. Place (do not pour) vermiculite directly onto and around the burner, covering the platform. Some logs may need to be moved temporarily aside to accommodate.



11. Place pebbles to taste around the installation. Do not place pebbles directly on the burner under the vermiculite.

1705DWKV2 - Complete L2 Installation

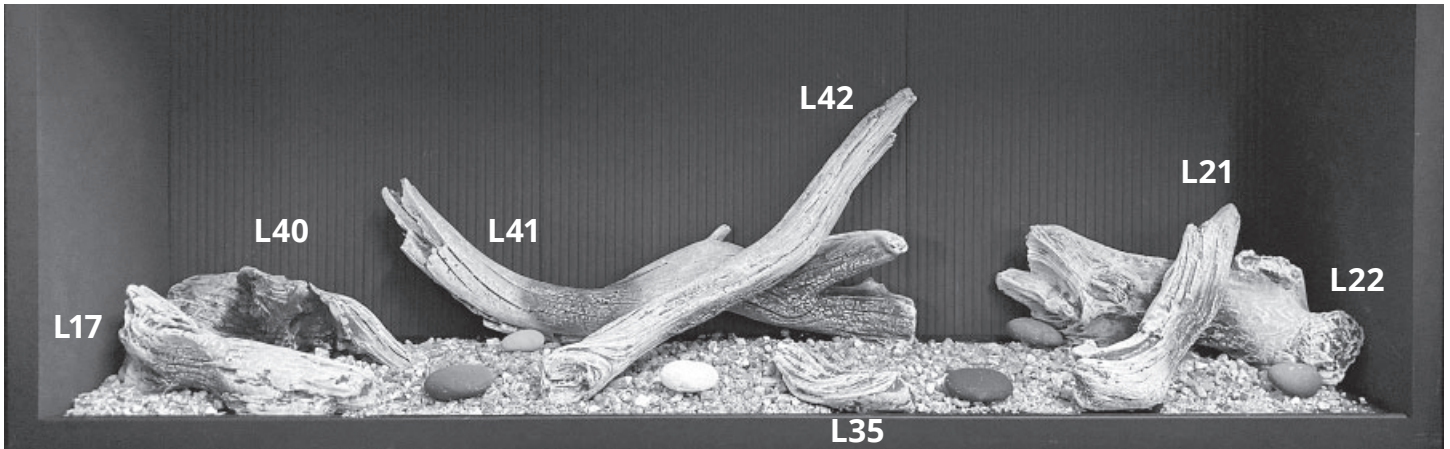

IMPORTANT

Approved for use only with vermiculite provided with your Valor fireplace. The use of any other products may void your fireplace warranty.

WARNING

Choking Hazard! Ensure that the fireplace area is clear of vermiculite particles as these could be ingested by small children. Vacuum area after installation.

Installation

Fuel Beds

Decorative Glass Murano 1700DGM

Material required

- Steel platform (supplied with appliance)
- Decorative Glass Murano Glass kit, which contains:
 - 1 bag of clear 1/2" fireglass
 - 8-pieces glass platform

Installation

Carefully unpack the kit.

1. Install the steel platform around the burner as indicated. The openings in the platform should be underneath.

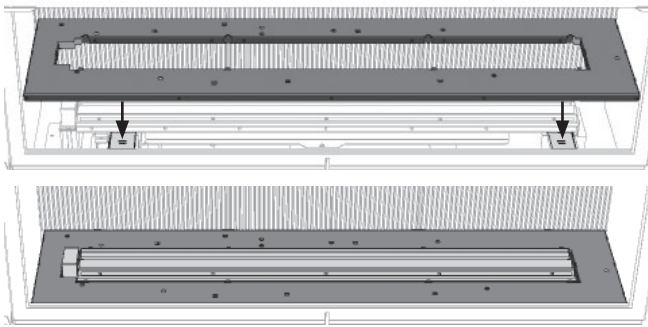

Installed platform

2. Install the glass plates on the platform, textured side underneath and smooth side on top. Follow the diagram below as the pieces are not all the same size.

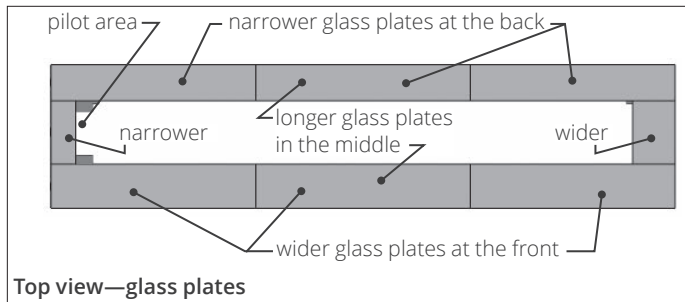

Top view—glass plates



Installed glass plates

3. Carefully spread the fireglass by hand, on the surface of burner forming a single layer to the approximate level of the top edge of the flange around the burner. Do not pour from the bag and do not pour too much to avoid blocking the burner ports.

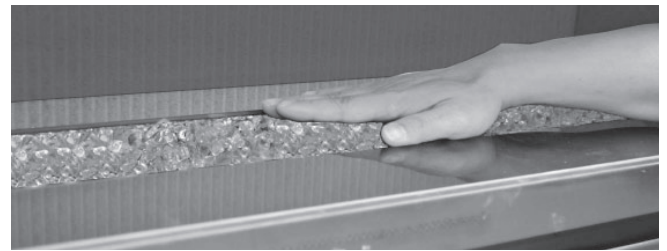

4. Some fireglass may be added on the platform to cover the edge of the burner and in the space in front and behind the pilot shield.

NOTE: Ensure the area *within* the pilot shield is clear of fireglass.

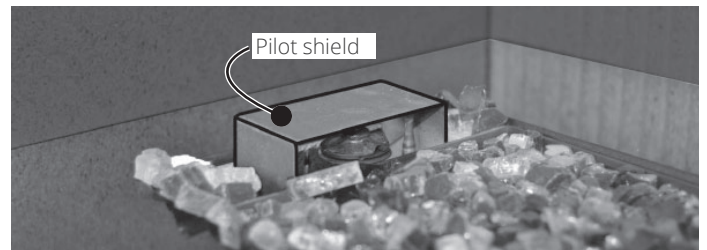

IMPORTANT

Approved for use only with the fireglass provided with your Valor fireplace or the tempered crushed fireglass brands *American Fireglass™* or *firegear*. The use of any other products may void your fireplace warranty.

WARNING

Choking Hazard! Ensure that the fireplace area is clear of fireglass particles as these could be ingested by small children. Vacuum area after installation.

Installation

Fuel Beds

Rocks & Shale Set 1714RSS

Material required

- Black steel platform (supplied with appliance)
- Rock & Shale Set, which contains:
 - 5 twigs



- 34 rocks (assorted colors)

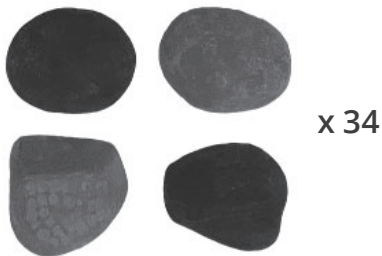

- 1/2lb-bag of 3/4" black shale
- 1/2lb-bag of 3/4" grey shale

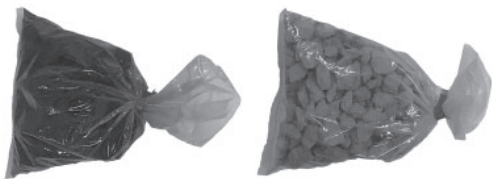

Carefully unpack the kit, as the logs are fragile.

Installation

1. Install the steel platform around the burner as indicated (no screws). The openings in the platform should be underneath.

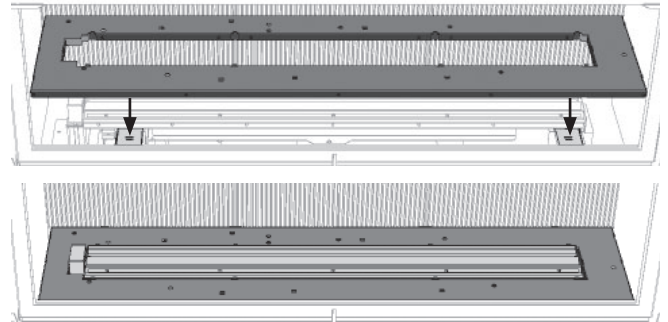

Installed platform

2. Distribute the mixed shale by hand directly onto the burner, forming a single layer. Do not pour from the bag and do not pour too much to avoid blocking the burner ports. Take care not to cover the pilot light.

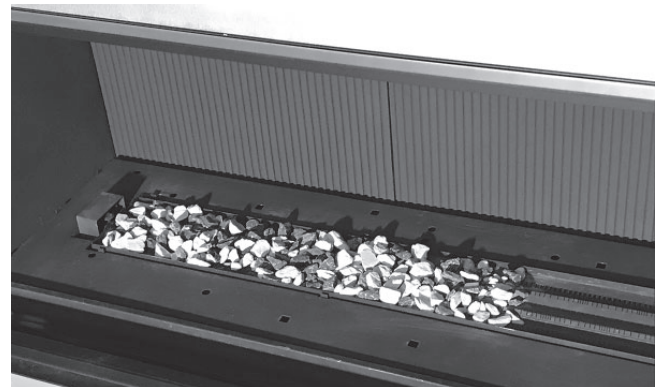

3. Place one rock behind the pilot light shield.



Installation

Fuel Beds

- Place the rest of the rocks evenly on the platform around the burner.



- Place the first twig #2 at the left hand end of the burner. Use the bigger rocks to keep the twig off the shale as much as possible. Be careful not to block the pilot light.



- Place the first twig #1 as shown. Use the bigger rocks to keep the twig off the shale as much as possible.



- Place twig #3 as shown, over the center of the burner. Use the bigger rocks to keep the twig off the shale as much as possible.



- Place the second twig #1 as shown. Use the bigger rocks to keep the twig off the shale as much as possible.



- Place the second twig #2 as shown. Use the bigger rocks to keep the twig off the shale as much as possible.

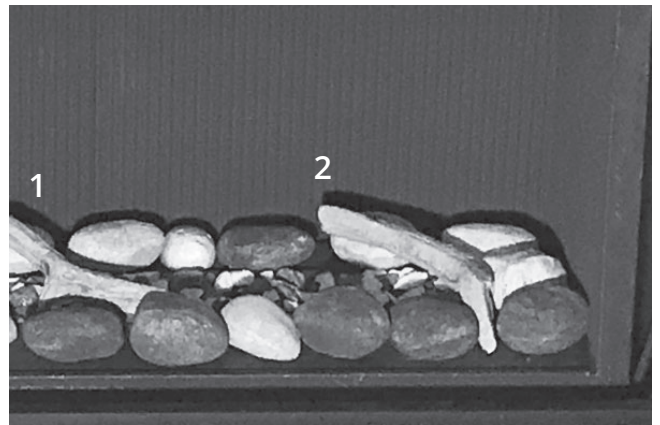



1714RSS—Rock and Shale Kit installed

IMPORTANT

Use only the ceramic rocks, twigs and shale provided with your Valor fireplace. The use of any other types of rocks, twigs or shale may void your fireplace warranty.

WARNING

Choking Hazard! Ensure that the fireplace area is clear of shale pieces as these could be ingested by small children. Vacuum area after installation.

Installation

Fuel Beds

Splitwood Kit 1705SWKV2

Material required

- Black steel platform (supplied with appliance)
- Driftwood Kit containing:
 - 9 logs
 - 1 bag of embers

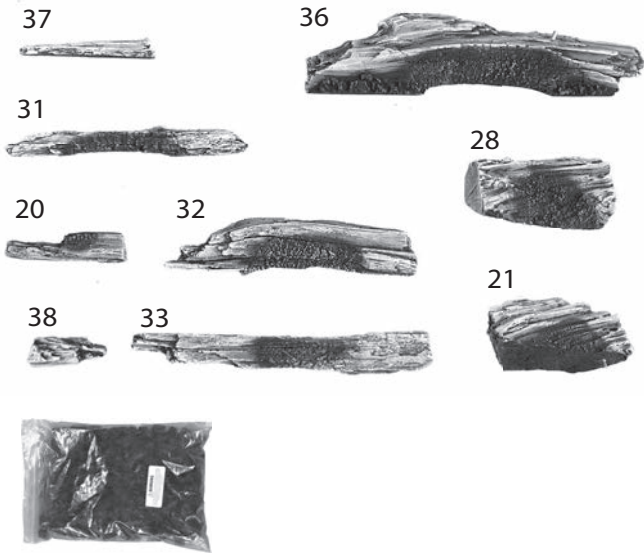

L2 Installation

1. Carefully unpack the kit, as the logs are fragile.
2. Install the steel platform around the burner as indicated. The openings in the platform should be underneath.

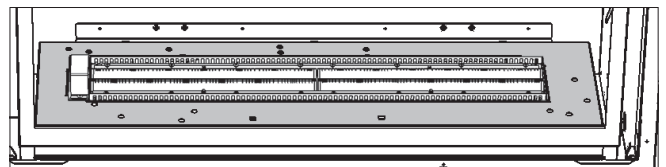
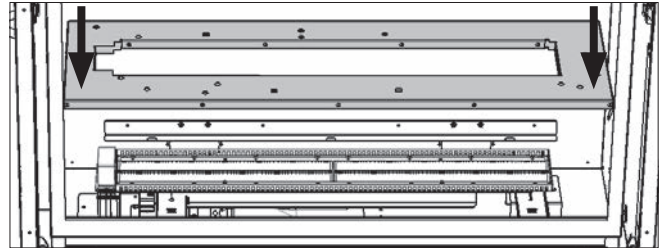

Installed platform

3. Place log 21 as shown with the pin in the hole. The left hand side of the log rests gently on the pilot shield.

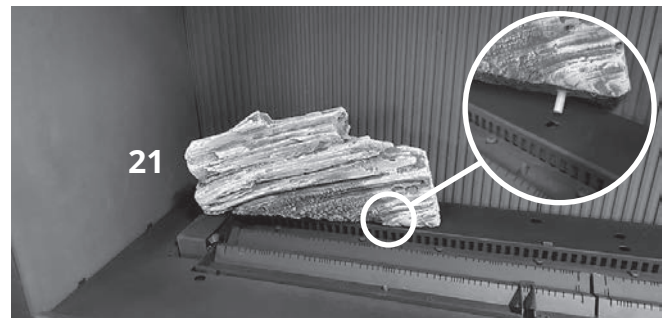

4. Place log 28 at the right end of the burner. There is a cutout that fits over the right rear corner of the burner - the log should be placed 1/8" away from the burner, not directly against it.

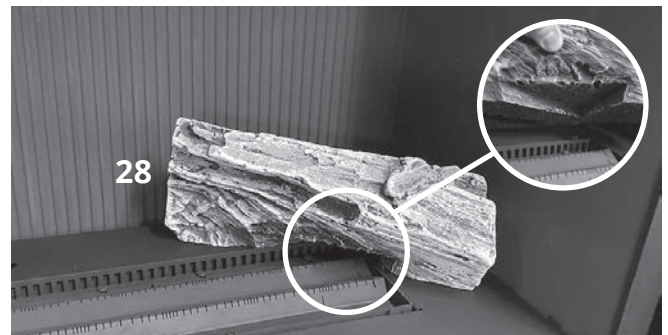

NOTE

Use of this log set may increase the possibility of soot formation when air shutters are set to the minimum setting. Although L2 fireplaces are fitted with a minimum air shutter stopper intended to prevent sooting with most log sets, it is possible some sooting may occur when using this log set and the air shutter is set to minimum position.

Evaluate the flame picture carefully after the unit has warmed up for fifteen minutes, and avoid setting the air shutter to minimum when there is limited rise in the venting system or the flame appears overly luminous and lazy with smoke trailing off the flame tips.

Refer to "Checking Operation and Aeration" on page 59 of this manual for more information.

Installation

Fuel Beds

5. Place log 36 as shown, centered between 21 and 28, resting on the rear platform.



6. Place log 32 with its hole on the pin on log 36. The log will cross the burner and rest on the front platform.

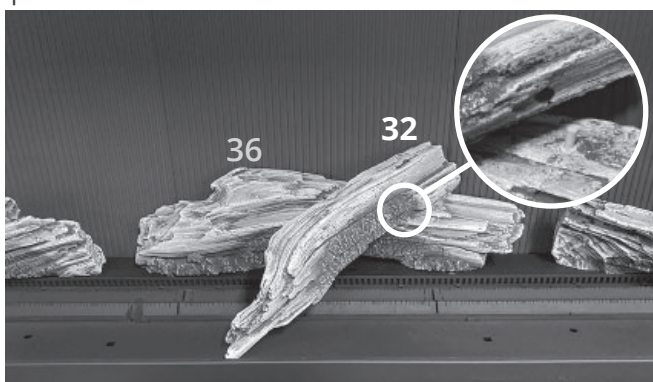

7. Place log 33 as shown, from on top of the groove in log 28 to the front platform.

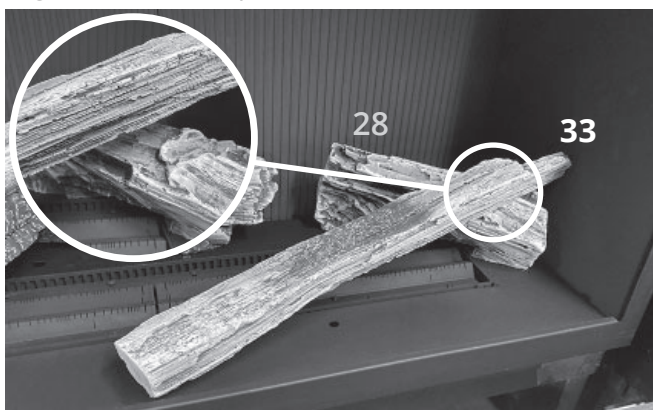

8. Place log 31 from groover on the top of 21 to the front platform.

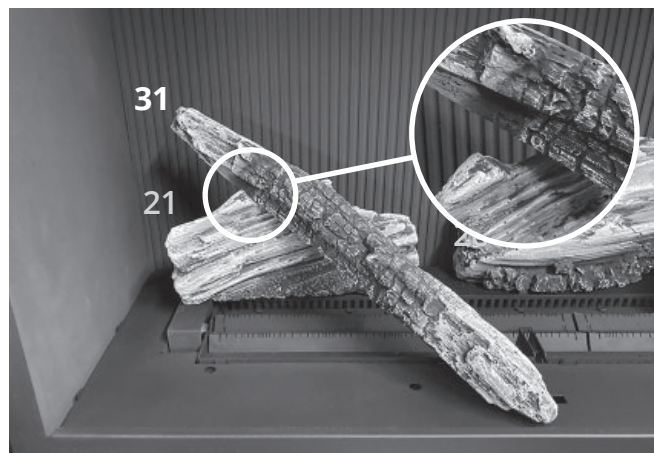

9. Place log 20 from the top of the pilot light to the front platform.

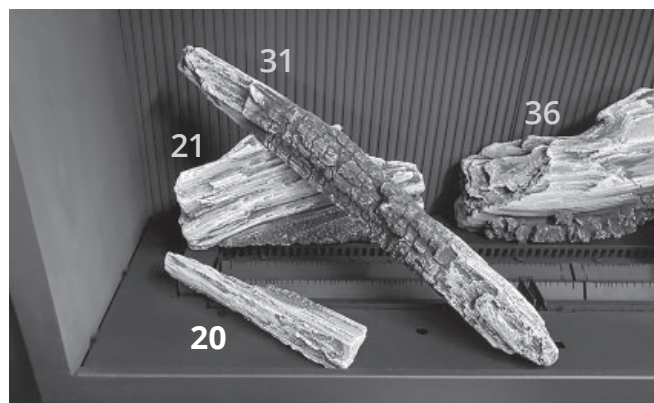

10. Place log 38 on the front platform between the ends of logs 31 and 33. The end should just touch the front edge of the burner.

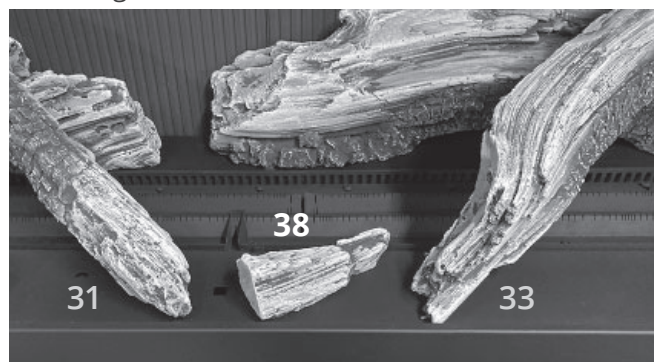

Installation

Fuel Beds

- Place log 37 on the right end of the front platform, just touching the edge of the burner.



- Place by hand (do not pour) embers among the logs, covering the burner.



IMPORTANT

Approved for use only with the ceramic embers and splinters provided with your Valor fireplace. The use of any other products may void your fireplace warranty.

⚠ WARNING

Choking Hazard! Ensure that the fireplace area is clear of embers / splinters as these could be ingested by small children. Vacuum area after installation.

1705SWKV2 - Complete L2 Installation

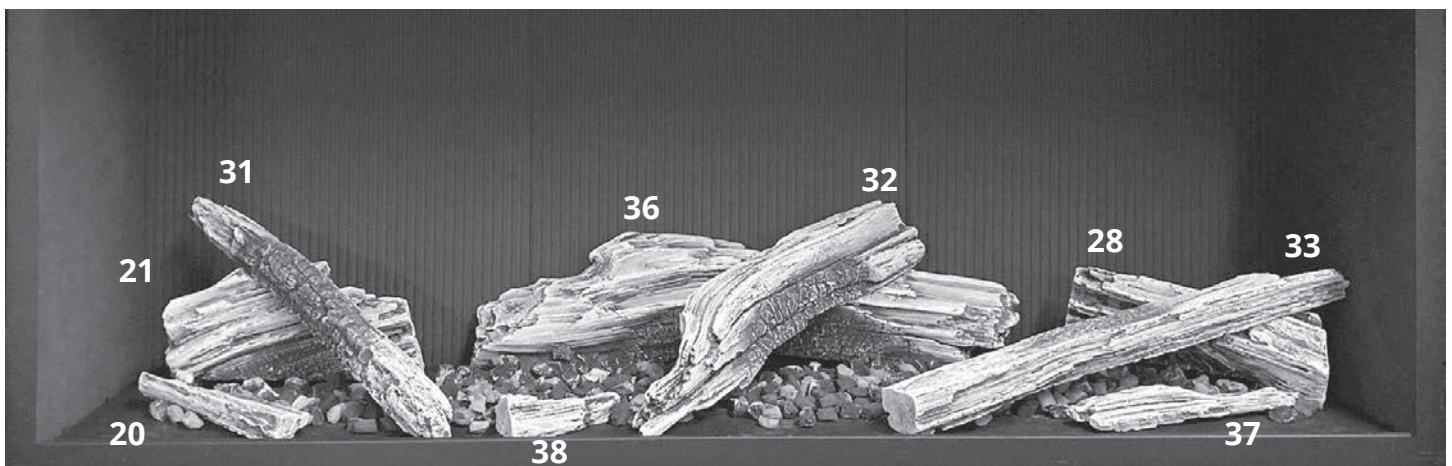

Installation

Fuel Beds

Birch Kit 1705BLKV2

Material required

- Black steel platform (supplied with appliance)
- Driftwood Kit containing:
 - 9 logs
 - 2 support pieces
 - 1 bag of embers

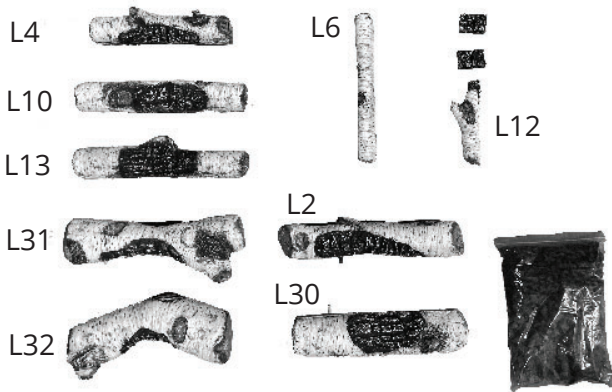

NOTE

Use of this log set may increase the possibility of soot formation when air shutters are set to the minimum setting. Although L2 and LX2 fireplaces are fitted with a minimum air shutter stopper intended to prevent sooting with most log sets, it is possible some sooting may occur when using this log set and the air shutter is set to minimum position.

Evaluate the flame picture carefully after the unit has warmed up for fifteen minutes, and avoid setting the air shutter to minimum when there is limited rise in the venting system or the flame appears overly luminous and lazy with smoke trailing off the flame tips.

Refer to "Checking Operation and Aeration" on page 59 of this manual for more information.

L2 1700 Installation

1. Carefully unpack the kit, as the logs are fragile.
2. Install the steel platform around the burner as indicated. The openings in the platform should be underneath.

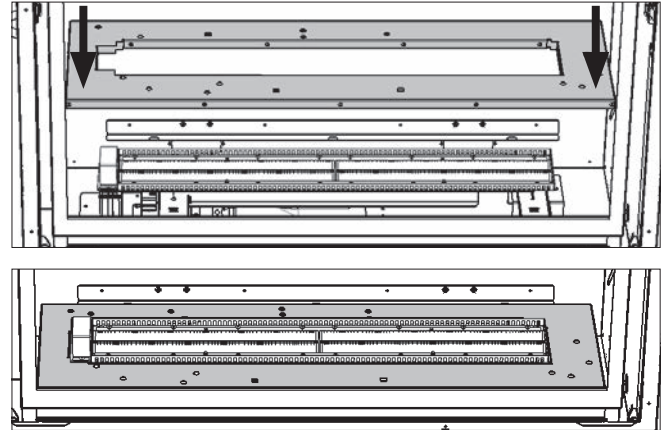

Installed platform

3. Place log L30 with the pin inserted in the hole as shown. Place the other end of the log gently on the pilot shield.

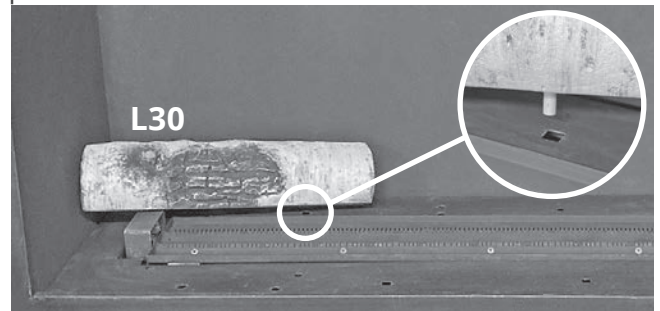

4. Place log L31 with the pin inserted in the hole in the media platform as shown, across the burner to the front of the media platform.

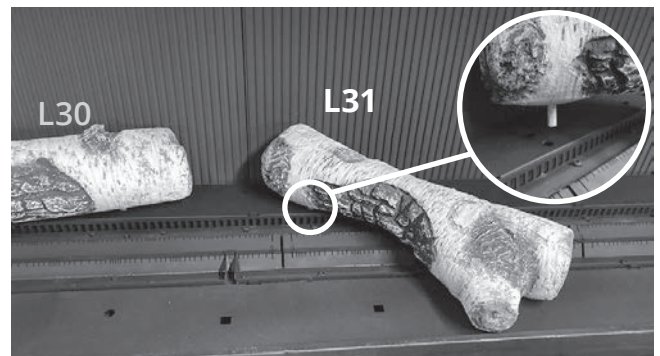

Installation

Fuel Beds

5. Place one of the rectangular support pieces under the front side of L31 as shown.



6. Place log L32 with its bottom cutout around the back right corner of the burner. Add the other rectangular support under its left side.

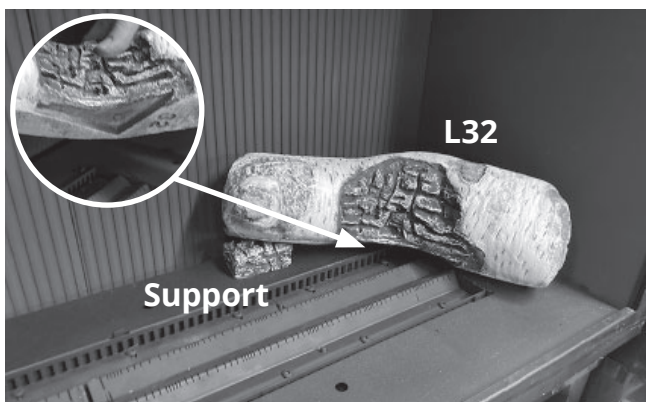

7. Place the pin of L2 into the hole on top of L30, and rest the other end on the media platform front.

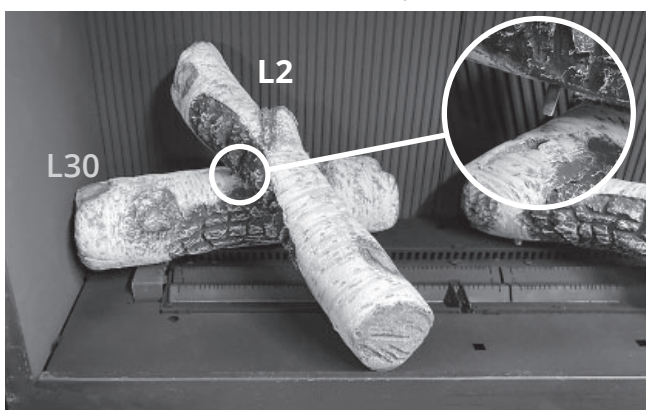

8. Place log L12 on the front left corner of the media platform. It will just touch the burner.



9. Place L13 on top of L31 as shown.

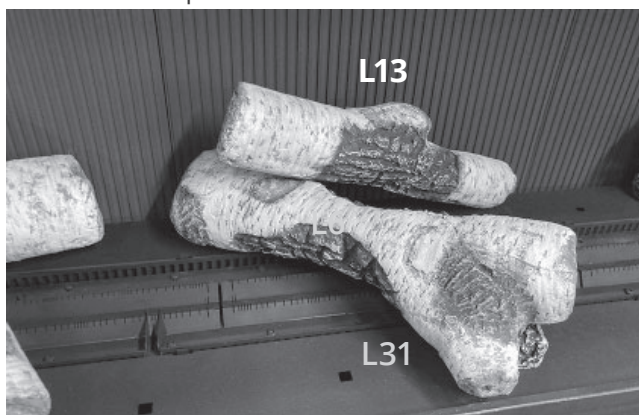

10. Place L6 on top of L31 as shown.

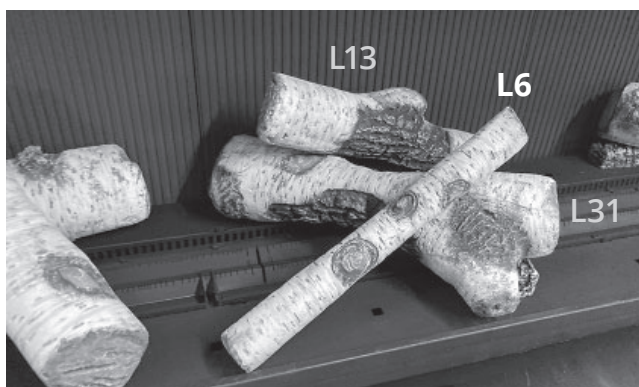

Installation

Fuel Beds

11. Place L4 across the burner as shown. It will later be placed on top of embers.

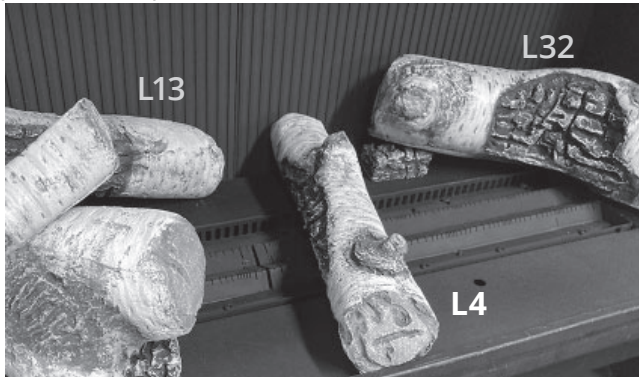

IMPORTANT

Approved for use only with the ceramic embers provided with your Valor fireplace. The use of any other products may void your fireplace warranty.

WARNING

Choking Hazard! Ensure that the fireplace area is clear of embers as these could be ingested by small children. Vacuum area after installation.

12. Place L10 on top of L32 as shown.



1705BLKV2 - Complete L2 Installation



Installation

Window Re-Installation & Checking

Refit and Check Window

1. Place the window in its bottom railing. Ensure to remove any vermiculite or glass particles in the railing before installing the window.

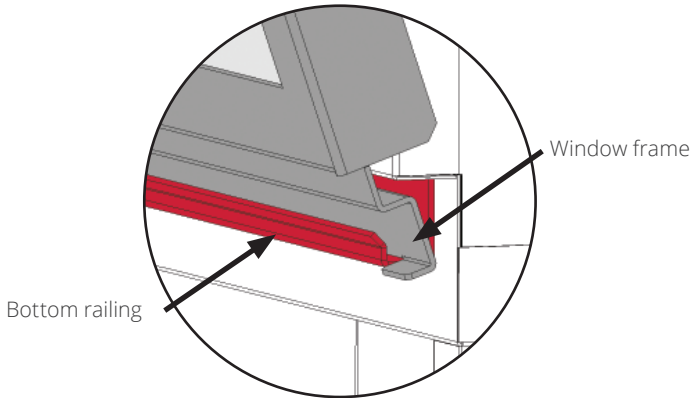

2. Push the top of the window frame against the firebox.

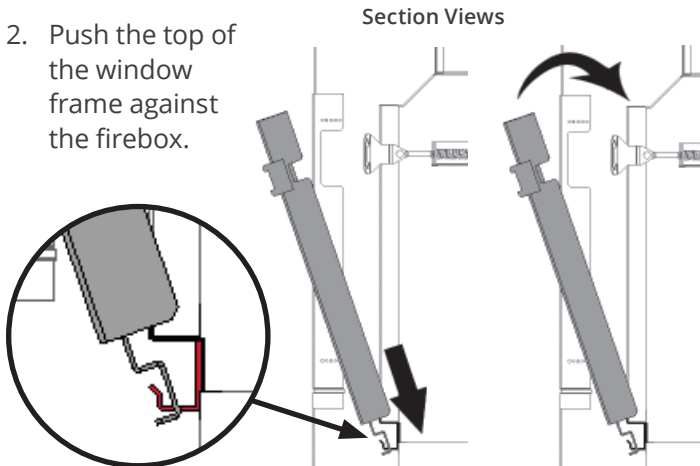

3. While you hold it, pull and hook the side levers back to the window brackets on each side.

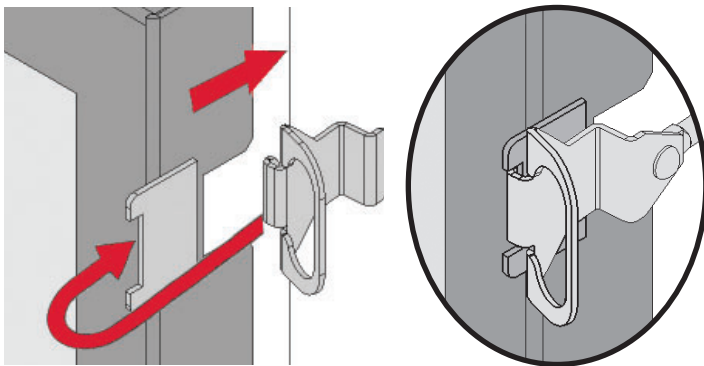

4. Pull out top of window to ensure spring loaded levers work properly.
5. Apply firm hand pressure around the window frame to ensure the window is sealed tight against the firebox.

! WARNING

The window unit must be correctly installed, fastened and sealed after servicing or serious bodily injury and/or damage to the appliance may result.

To ensure a safe operation:

- Double-check that the bottom of the window frame is correctly installed in the bottom support railing;
- Verify that the levers are hooked properly to the window tabs then;
- Pull out the top of the window and release it to insure the springs return it;
- Ensure the window is sealed before operation.

! WARNING

Failure to install the window correctly can:

- Leak carbon monoxide.
- Affect the performance of the fireplace.
- Damage components.
- Cause overheating resulting in dangerous conditions.

Damage caused by incorrect window installation is not covered by the Valor Warranty.

6. If the Hot Glass Warning plate has been removed from the front lower corner of the window, re-install it by sliding it between the glass and the frame as indicated.

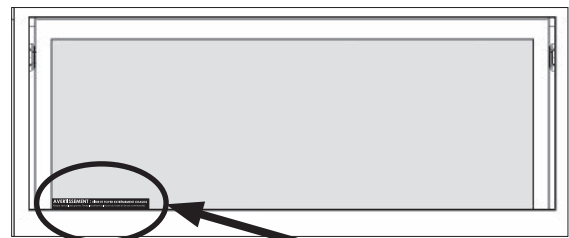

! WARNING: EXTREMELY HOT GLASS AND FIREPLACE
Risk of severe burns. Keep Children away from fireplace & controls.
Risque de brûlures graves. Tenez les enfants à l'écart du foyer et de ses commandes.
AVERTISSEMENT : VITRE ET FOYER EXTREMEMENT CHAUDS

! WARNING: EXTREMELY HOT GLASS AND FIREPLACE
Risk of severe burns. Keep Children away from fireplace & controls.

Hot Glass Warning Plate

Installation

Wall Switch

Install Remote Battery and Wall Switch Kit (required)

The Remote Battery and Wall Switch Kit is provided with this appliance. It connects to the receiver in the fireplace.

The receiver is located under the firebox, left of the control valve. It is maintained in position with **Velcro** bands.

1. Pull out the receiver from its location to connect the battery holder and wall switch.
2. Feed the 'white connector end' of the harness assembly through side holes in fireplace liner body to receiver. Ensure sufficient harness length to allow for removal of receiver. Note - coil up any extra harness at fireplace end.
3. Connect switch to auxillary 5-pin junction and power connection to jack.

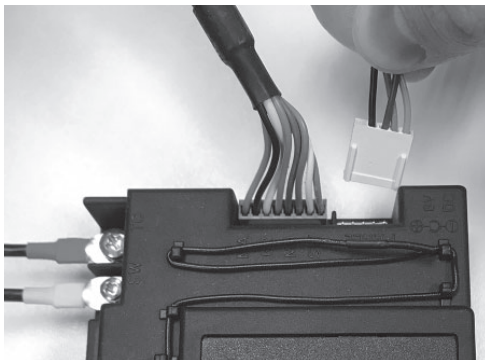

IMPORTANT: The connection can only be done one way.

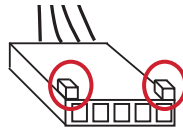

Do not force it or damage the pins on the receiver box!



4. Run harness assembly to mounted position of junction box, securing harness to framing using insulated staples (not included)
5. Feed harness assembly through a restrain on rear of junction box, feeding through until harness sheath is pinched by retainer and providing sufficient length to make connection to rear of switch and battery holder.

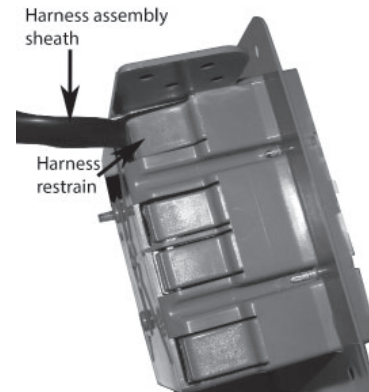

6. Secure junction box to the mounting surface using appropriate fasteners (not included)
7. Align molex connection on switch cable of harness assembly and connect to switch.

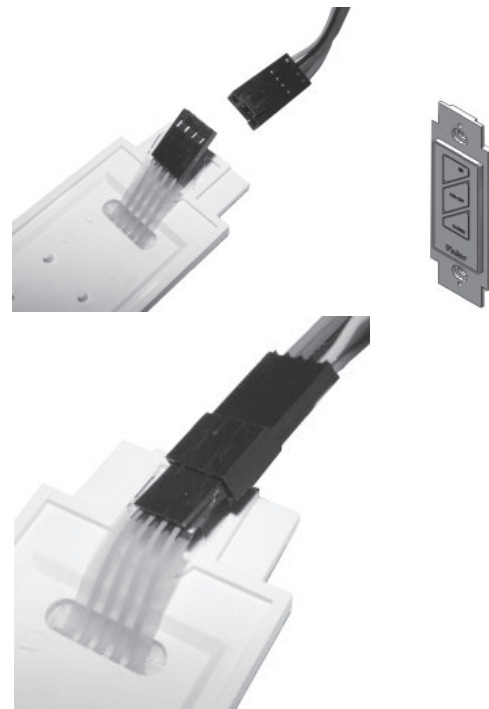

Caution

DO NOT PUT BATTERIES IN THE BATTERY HOLDER until the wires are connected to the burner control unit as short-circuit could result in the destruction of the electrical components.

Do not run the switch wire over the top of the firebox. Route the wire so it does not contact the firebox.

Installation

Wall Switch

8. Mount switch plate to junction box with 2 long screws provided. Note: switch position left or right to suit homeowner wishes.

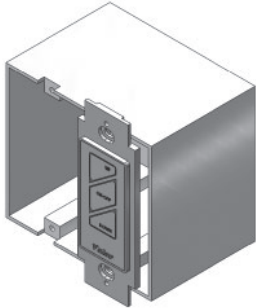

9. Locate and secure magnet plate using 2 'long' screws provided

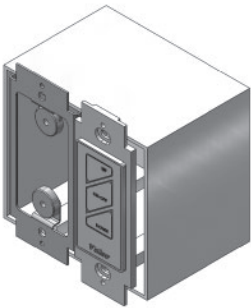

10. Place and secure cover plate to box using 4 screws provided

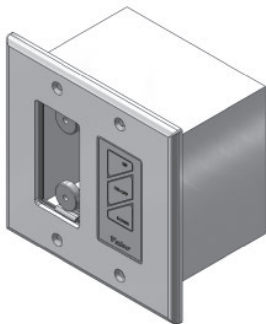

11. Feed cable tie through the 2 side slots of battery cover assembly.
12. Position battery holder to rear face and secure together with cable tie. note clearance is required for battery snap connection.

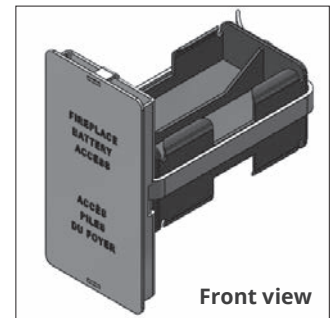
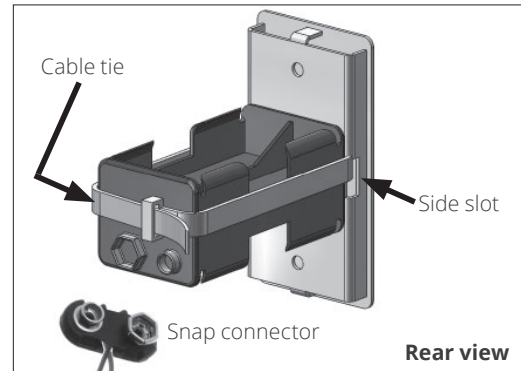

13. Make the snap connection, load 4 AA alkaline batteries into holder (included with fireplace) then feed back into junction box assembly.
- Note: Do not put batteries in the receiver, only in the battery holder by the wall switch.**

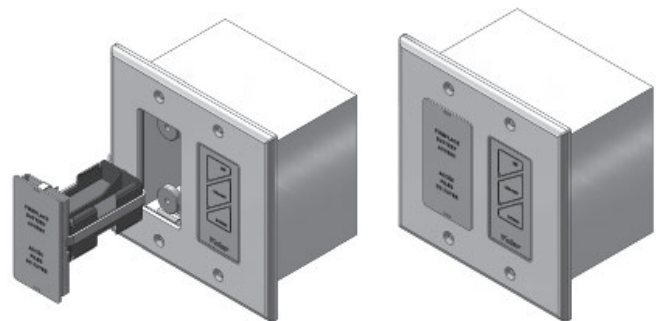

14. Test the operation of the wall switch—see ""Appendix C—Wall Switch Operation"" on page 74.

⚠ Caution

DO NOT USE a screwdriver or other metallic object to remove the batteries from the battery holder or the handset! This could cause a short circuit to the receiver.

To avoid short-circuit to the receiver, position the antenna so that it DOES NOT TOUCH the ignition wire.

Installation

Radio Frequency

918.0 MHz for USA and Canada.

This device complies with Part 15 of the FCC Rules and with Industry Canada license-exempt RSS standard(s). Operation is subject to the following two conditions:

- (1) this device may not cause harmful interference, and
- (2) this device must accept any interference received, including interference that may cause undesired operation.

Remote Control Initial Pairing

The receiver and the handset of the remote control system must be initially paired before the first use. (Note that batteries must already be installed in the wall mounted battery holder)

1. Insert two 1.5 V AAA **alkaline** batteries in the handset.
2. Locate the Reset button on the front side of the receiver.
3. With a thin object, press and hold the receiver's RESET button until you hear one short and one long beeps. After the second beep, release the reset button.
4. Within the subsequent 20 seconds, press and hold the  button on the remote handset for 2-3 seconds. **CONN** will be displayed on the handset during the pairing sequence. You will hear two short beeps confirming the pairing is done.

If you hear one long beep, the pairing sequence has failed or the wiring is incorrect.

This is a one time pairing only and is not required when changing the batteries of the handset or battery holder. The remote control system is now ready to use.

Remote Control Pairing

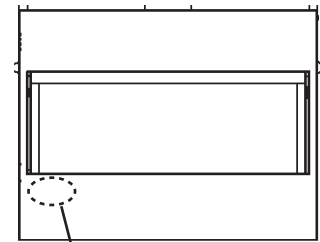
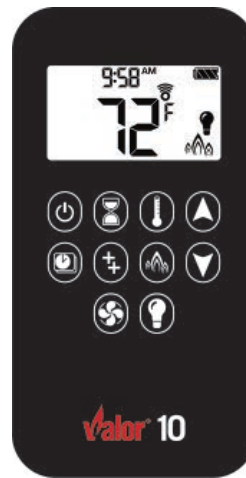

Receiver behind front panel, left of gas valve

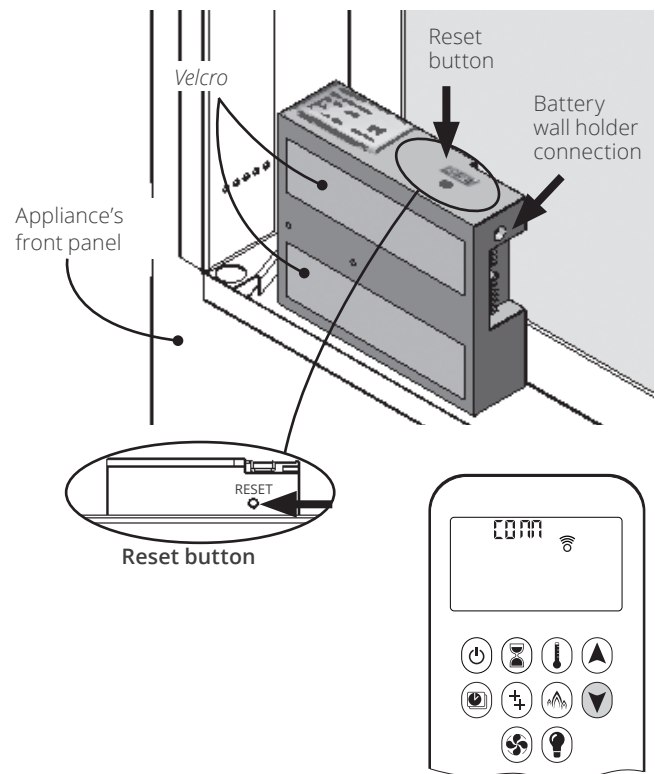

Installation

Remote Control Pairing

Install Remote Control Handset Wall Holder

The remote control kit for this fireplace comes complete with a wall-mounted holder. This holder is not required in all installations but is provided as an optional feature for those customers who wish to mount the remote handset to the wall.



To install the holder to the wall, find a convenient location and use the hardware provided with the kit. Cover the screws with the included caps to finish the mounting.

Once mounted, the holder is magnetic - simply place the remote gently into the holder.

IMPORTANT: The location of the remote control handset is important to assure proper temperature regulation. To obtain a constant temperature, we recommend that the handset should be **between 3 and 15 feet away from the appliance but not directly above it.** We also advise that the handset should be located away from any other heat source and not in direct sunlight as this may affect the temperature sensor located in the remote handset.

Installation

Checking Operation and Aeration

Checking Operation

Turn the fireplace flame up and down using the remote control to confirm that the full range of inputs is achieved—see the remote control operation instructions in “Appendix B—Remote Control Operation” on page 67.

Adjusting Aeration

Light the fire and allow the unit to warm up for 10–15 minutes to evaluate the flame picture. The burner is equipped with an adjustable shutter to control primary aeration. The shutter is factory-set to an aeration gap which will give optimum performance for the vast majority of installations.

Depending on the fuel bed used, altitude and other considerations, the flame picture may be improved by adjusting the aeration. The need for adjustment should be determined only by operating the appliance with the fuel bed, panels and window installed and evaluating the flame picture after a 15-minute warm-up.

Increasing aeration will cause the flames to appear more transparent and blue showing more ceramic effects glow.

Decreasing aeration will cause the flames to appear more yellow or orange showing less ceramic effects glow.

Too little aeration may result in black carbon forming on logs or roof panel and dropping into the firebox. May also result in carbon or soot stains on the vent termination and exterior wall around the termination! The Manufacturer is not responsible for any damage caused by an air shutter setting with too little aeration.

Locating Aeration Control

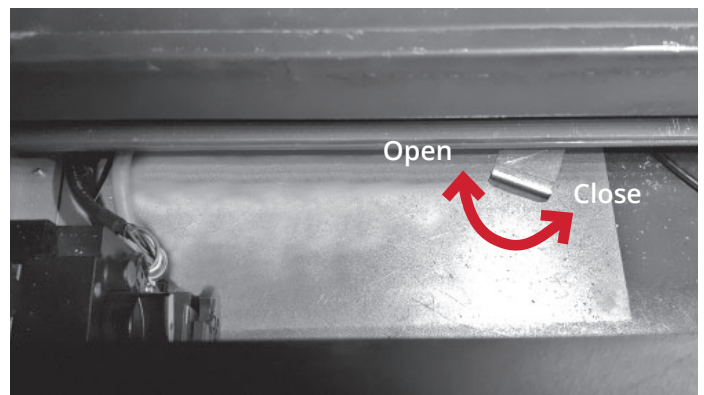
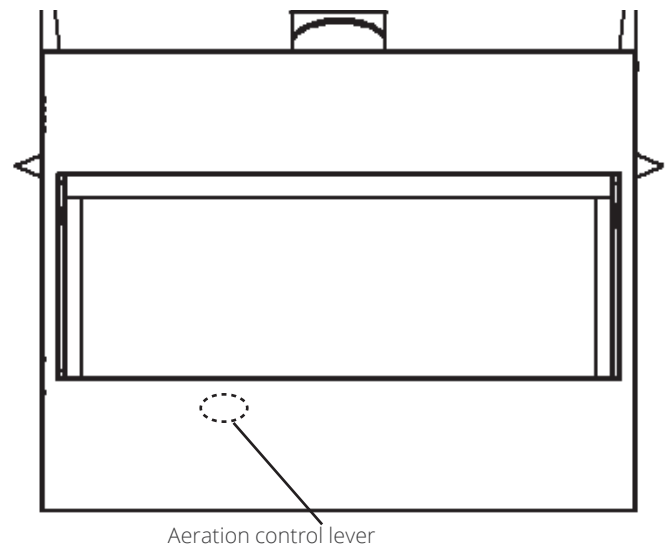

Top view—Air shutter lever located under the firebox behind the front panel

Installation

Trim & Barrier Screen

Install trim plinth support

Install the trim plinth support hooking it vertically on the stiffener bracket, as shown. The stiffener bracket is located just behind the front panel below the window.

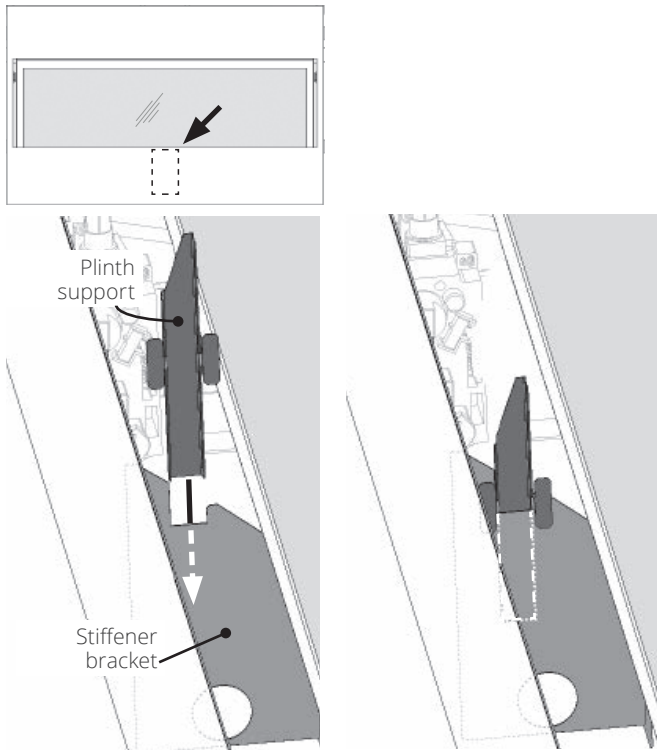

Install Trim and Barrier Screen

Install the trim chosen by the customer for their fireplace. Install as well the barrier screen which is provided with the trim.

Show the customer how to remove the barrier screen to access the controls.

Follow the instructions provided with the trim and leave those instructions behind for the customer's further reference.

1730CIK—Clean Installation Kit

WARNING

HeatShift System MUST be installed on this appliance when using 1730CIK—Clean Installation Kit.

If you are installing the 1730CIK Clean Installation Kit, you need to do it **BEFORE** the cement board.

1. Break off tabs from each corner of the fireplace's front opening (8 tabs, 2 at each corner). Bend tabs back and forth to break them, or cut them with tin snips as indicated in the kit's installation instructions.

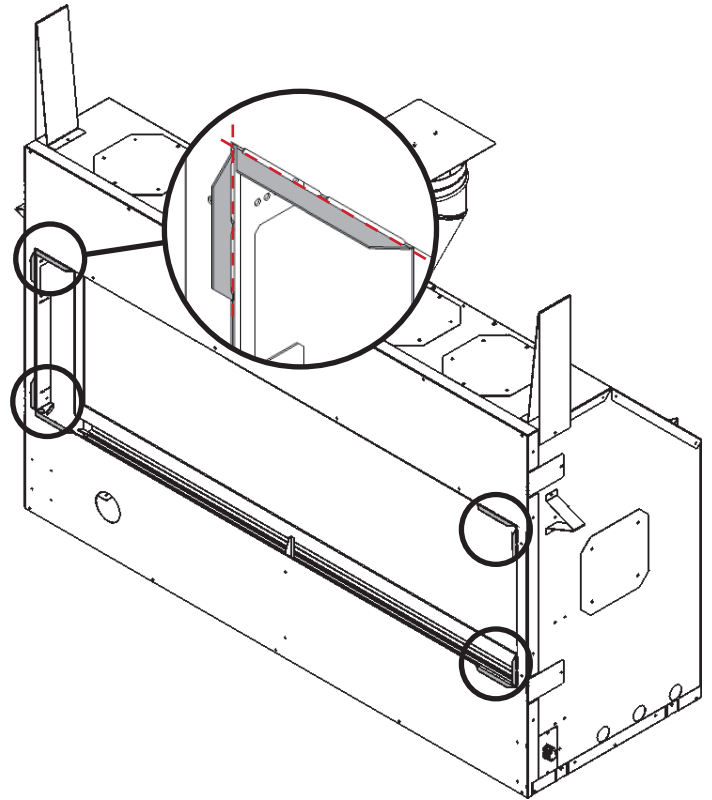

2. Remove the internal convection baffle inside the appliance case, above the firebox. See "Remove Convection Baffle" on page 34 and "Appendix D—HeatShift System" on page 75

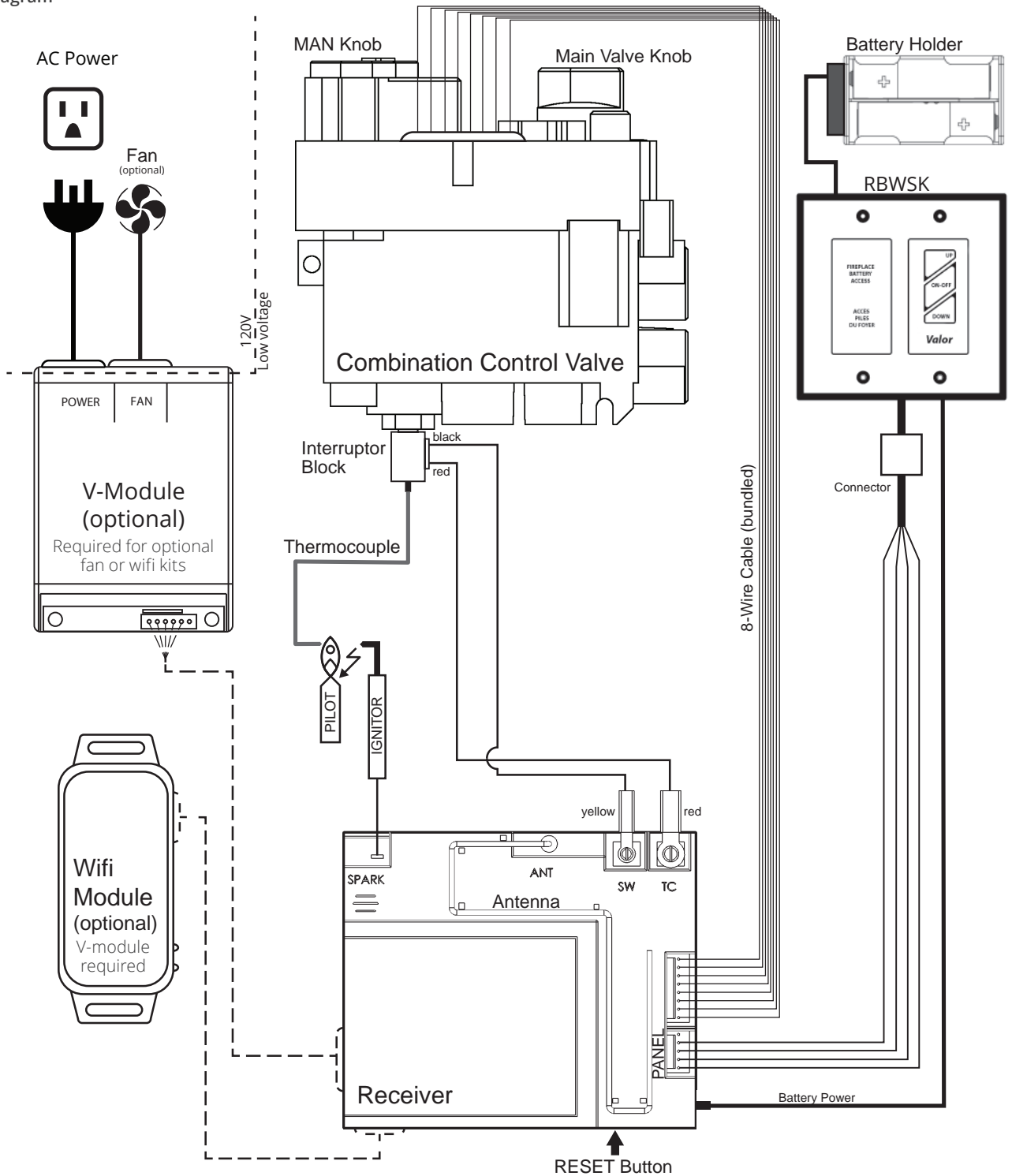

Wiring Diagram

GV60 Wiring Diagram



⚠ WARNING
NO ELECTRICAL CONNECTION ALLOWED
for any outdoor installation!

Approved Venting Components

Approved Direct Vent Suppliers for Valor Models 1700 and 2500								
  Venting Parts Description		Venting Parts Code / availability by Manufacturer					BDM	
		DURA-VENT	SELKIRK	ICC EXCEL DIRECT	AMERIVENT	MILES INDUSTRIES		
Termination Caps	Horizontal	Standard Co-axial	46DVA-HC	4DT-AHC	TM-4HT	4DHC round	658DVK2	DVR6-HC
		Deluxe Co-axial	—	—	TM-4RHT	4DHCS square	—	DVR6-HCP
		High Wind Co-axial	46DVA-HC	—	TM-DHT	—	—	—
	Vertical	Standard Co-axial	46DVA-VC	4DT-VT	—	4DVC	—	DVR6-VCH
						4DH-1313		DVR6-VCSB
						—		—
		High Wind Co-axial	46DVA-VCH	—	TM-4SVT	—	—	—
		Extended Co-axial	46DVA-VCE	—	—	—	—	—
		Co-linear	46DVA-CL34 46DVA-CL34P	4DT-34IK35 (3x4 kit)	TM-IVT	HCL-99-43	559CLT	942034
						HCL-913-43		940034B
HCL-1313-43	940034HWS							
DVIK43	940034RD							
Snorkel, 14" Rise	46DVA-SNK14	4DT-ST14	TM-4ST14	4D14S	—	DVR6-SNK14		
Snorkel, 36" Rise	46DVA-SNK36	4DT-ST36	TM-4ST36	4D36S	—	DVR6-SNK36		
Vent Adapters	Co-axial-to-Co-linear Adapter	46DVA-GCL34 46DVA-34CLAA	ADT-AAC	TM-4CAA	4DCAB43	1156CLA	DVR6-A34	
	Co-linear-to-Co-axial Adapter	46DVA-CT 46DVA-34CLTA	ADT-CTB	TM-CTA	4DCAT43	—	DVF34-A6	
Aluminum Flexible Liner	3" or 4" diameter	NOTE: 2-ply liner approved to CAN/ULC S635 suitable for venting gas appliances. As manufactured by Z-Flex, Flexmasters or others.						
		2280 Series	AF3-35L	TM-ALK43 TM-ALT43	—	—	952703 952704	
Adjustable Pipe Length and Pipe Extensions 4" x 6-5/8"	Galvanized or Black	46DVA-08A 46DVA-08AB (3" to 7")	—	—	4D7A or 4D7AB (3" to 5")	—	DVR6-08A DVR6-08AB	
	Galvanized or Black	46DVA-16A 46DVA-16AB (3" to 14-1/2")	ADT-AJ12 ADT-AJ12B (4" to 10")	TC-4DLS1 TC-4DLS1B	4D12A or 4D12AB (3" to 10")	—	DVR6-16A DVR6-16AB	
	Galvanized or Black	46DVA-17TA 46DVA-17TAB (11" to 17")	ADT-TL14 ADT-TL14B (14" to 22")	TC-4DLS2 TC-4DLS2B (1-7/8" – 21")	4D16A or 4D16AB (3" to 14")	—	—	
	Galvanized or Black	46DVA-24TA 46DVA-24TAB (17" to 24")	ADT-TL38 ADT-TL38B (38" to 70")	TC-4DLA30 TC-4DLA30B (16.5" – 29")	4D26A or 4D26AB (3" to 24")	—	—	
	Coaxial Flex	46DVA-36FF 46DVA-60FF 46DVA-120FF	—	—	—	—	—	
DV Elbows	30°	Galvanized	46DVA-E30	—	—	—	—	
		Galvanized	46DVA-E45 (swivel)	4DT-EL45	TE-4DE45	4D45L	—	DVR6-E45
	45°	Black	46DVA-E45B (swivel)	4DT-EL45(B)	TE-4DE45B	4D45LB	—	DVR6-E45B
		Galvanized	46DVA-E60	—	—	—	—	—
	90°	Galvanized	46DVA-E90 (swivel)	4DT-EL90	TE-4DE90	4D90L	—	DVR6-E90
Black		46DAV-E90B (swivel)	4DT-EL90(B)	TE-4DE90B	4D90LB	—	DVR6-E90B	

Approved Venting Components

Venting Parts Description			Venting Parts Code / availability by Manufacturer					
			DURA-VENT	SELKIRK	ICC EXCEL DIRECT	AMERIVENT	MILES INDUSTRIES	BDM
Pipes 4" x 6 5/8" (ID x OD)	6" long	Galvanized	46DVA-06	4DT-06	TC-4DL6	—	—	DVR6-06
		Black	46DVA-06B	4DT-06(B)	TC-4DL6B			DVR6-06B
	7" long	Galvanized	—	—	—	4D7	—	—
		Black	—	—	—	4D7B		
	9" long	Galvanized	46DVA-09	4DT-09	TC-4DL9	—	—	DVR6-09
		Black	46DVA-09B	4DT-09(B)	TC-4DL9B			DVR6-09B
	12" long	Galvanized	46DVA-12	4DT-12	TC-4DL1	4D12	—	DVR6-12
		Black	46DVA-12B	4DT-12(B)	TC-4DL1B	4D12B		DVR6-12B
	18" long	Galvanized	46DVA-18	4DT-18	—	—	—	DVR6-18
		Black	46DVA-18B	4DT-18(B)				DVR6-18B
	24" long	Galvanized	46DVA-24	4DT-24	TC-4DL2	4D2	—	DVR6-24
		Black	46DVA-24B	4DT-24(B)	TC-4DL2B	4D2B		DVR6-24B
	36" long	Galvanized	46DVA-36	4DT-36	TC-4DL3	4D3	—	DVR6-36
		Black	46DVA-36B	4DT-36(B)	TC-4DL3B	4D3B		DVR6-36B
	48" long	Galvanized	46DVA-48	4DT-48	TC-4DL4	4D4	—	DVR6-48
		Black	46DVA-48B	4DT-48(B)	TC-4DL4B	4D4B		DVR6-48B
Flashings	Roof Flashing 0/12-6/12		46DVA-F6	4DT-AF6	TF-4FA	4DF (0/12-5/12)	—	DVR6-AF012
	Roof Flashing 7/12-12/12		46DVA-F12	4DT-AF12	TF-4FB	4DF12 (6/12-12/12)	—	DVR6-AF712
	Flat Roof Flashing		46DVA-FF	—	TF-4F	—	—	DVR6-TCF
	Masonry Flashing		—	—	TF-4MF	—	559FSK	—
	New Siding Flashing		—	—	—	—	658NSFK	—
Various Venting System Parts	Wall Thimble		46DVA-WT	4DT-WT1	TM-4WT	4DWT	—	DVR6-WTU
	Storm Collar		46DVA-SC	4DT-SC	TM-SC	4DSC	—	DVT68-SC
	Decorative Plate		46DVA-DC	—	TM-4TR TM-4TP	4DFPB	—	DVR6-DC
	Support Box	Cathedral Ceiling	46DVA-CS	4DT-CCS	TM-4SS	4DRSB	—	DVR6-CS
		Regular Ceiling	—	4DT-CS	—	—	—	—
	Ceiling Firestop		46DVA-FS	4DT-FS	TM-4RDS TM-CS	4DFSP	—	DVR6-CFS
	Attic Radiation Shield / Firestop		46DVA-IS	4DT-AIS	TM-4AS	4DAIS12 (12") 4DAIS36 (36")	—	DVR6-AIS
	Wall Strap		46DVA-WS	4DT-WSB	TM-WS	4DWS	—	DVR6-WS
	Vinyl Siding Standoff		46DVA-VSS	4DT-VSS (before siding) 4DT-VSSB (after siding)	TM-VSS	4DHVS	—	DVR6-VSS
	Elbow Strap / Offset Support		46DVA-ES	4DT-OS	TM-OS	—	—	DVR6-ES
	Terminal Guard		46DVA-WG	—	TM-HTS TM-RHTS	—	845TG 658TG	DVR6-SHRD

- Notes:**
1. Follow instructions supplied with each manufacturer's components.
 2. Unless otherwise specified, all the parts and assemblies from the above table are to be used with 4" x 6-5/8" pipes.
 3. Do not mix components from different vent manufacturers, except Miles Industries' components, certified to use with other manufacturers'.

Commonwealth of Massachusetts

State of Massachusetts Carbon Monoxide Detector/Vent Terminal Signage Requirements

For all side wall horizontally vented gas fueled equipment installed in every dwelling, building or structure used in whole or in part for residential purposes, including those owned or operated by the Commonwealth and where the side wall exhaust vent termination is less than seven (7) feet above finished grade in the area of the venting, including but not limited to decks and porches, the following requirements shall be satisfied:

1. INSTALLATION OF CARBON MONOXIDE DETECTORS.

At the time of installation of the side wall horizontal vented gas fueled equipment, the installing plumber or gas fitter shall observe that a hard wired carbon monoxide detector with an alarm and battery back-up is installed on the floor level where the gas equipment is to be installed. In addition, the installing plumber or gas fitter shall observe that a battery operated or hard wired carbon monoxide detector with an alarm is installed on each additional level of the dwelling, building or structure served by the side wall horizontal vented gas fueled equipment. It shall be the responsibility of the property owner to secure the services of qualified licensed professionals for the installation of hard wired carbon monoxide detectors.

a. In the event that the side wall horizontally vented gas fueled equipment is installed in a crawl space or an attic, the hard wired carbon monoxide detector with alarm and battery back-up may be installed on the next adjacent floor level.

b. In the event that the requirements of this subdivision can not be met at the time of completion of installation, the owner shall have a period of thirty (30) days to comply with the above requirements; provided, however, that during said thirty (30) day period, a battery operated carbon monoxide detector with an alarm shall be installed.

2. APPROVED CARBON MONOXIDE DETECTORS. Each carbon monoxide detector as required in accordance with the above provisions shall comply with NFPA 720 and be ANSI/UL 2034 listed and IAS certified.

3. SIGNAGE. A metal or plastic identification plate shall be permanently mounted to the exterior of the building at a minimum height of eight (8) feet above grade directly in line with the exhaust vent terminal for the horizontally vented gas fueled heating appliance or equipment. The sign shall read, in print size no less than one-half (1/2) inch in size, "GAS VENT DIRECTLY BELOW. KEEP CLEAR OF ALL OBSTRUCTIONS".

4. INSPECTION. The state or local gas inspector of the side wall horizontally vented gas fueled equipment shall not approve the installation unless, upon inspection, the inspector observes carbon monoxide detectors and signage installed in accordance with the provisions of 248 CMR 5.08(2)(a)1 through 4.

(b) EXEMPTIONS: The following equipment is exempt from 248 CMR 5.08(2)(a)1 through 4:

1. The equipment listed in Chapter 10 entitled "Equipment Not Required To Be Vented" in the most current edition of NFPA 54 as adopted by the Board; and

2. Product Approved side wall horizontally vented gas fueled equipment installed in a room or structure separate from the dwelling, building or structure used in whole or in part for residential purposes.

(c) MANUFACTURER REQUIREMENTS - GAS EQUIPMENT VENTING SYSTEM PROVIDED. When the manufacturer of Product Approved side wall horizontally vented gas equipment provides a venting system design or

Commonwealth of Massachusetts

venting system components with the equipment, the instructions provided by the manufacturer for installation of the equipment and the venting system shall include:

1. Detailed instructions for the installation of the venting system design or the venting system components; and
2. A complete parts list for the venting system design or venting system.

(d) MANUFACTURER REQUIREMENTS - GAS EQUIPMENT VENTING SYSTEM NOT PROVIDED.

When the manufacturer of a Product Approved side wall horizontally vented gas fueled equipment does not provide the parts for venting the flue gases, but identifies "special venting systems", the following requirements shall be satisfied by the manufacturer:

1. The referenced "special venting system" instructions shall be included with the appliance or equipment installation instructions; and
2. The "special venting systems" shall be Product Approved by the Board, and the instructions for that system shall include a parts list and detailed installation instructions.

(e) A copy of all installation instructions for all Product Approved side wall horizontally vented gas fueled equipment, all venting instructions, all parts lists for venting instructions, and/or all venting design instructions shall remain with the appliance or equipment at the completion of the installation.

Appendix A—Lighting Instructions

FOR YOUR SAFETY, READ BEFORE LIGHTING

WARNING: If you do not follow these instructions exactly a fire or explosion may result causing property damage, personal injury or loss of life.

- A. This appliance has a pilot which must be lighted by hand or by remote control. Follow these instructions exactly. To save gas, turn the pilot off when not using the appliance for a prolonged period of time.
- B. **BEFORE LIGHTING**, smell all around the appliance area for gas. Be sure to smell next to the floor because some gas are heavier than air and will settle on the floor.
- WHAT TO DO IF YOU SMELL GAS
- Do not try to light any appliance.
 - Do not touch any electric switch; do not use any phone in your building.
 - Immediately call your gas supplier from a neighbor's phone. Follow the gas supplier's instructions.
 - If you cannot reach your gas supplier, call the fire department.
- C. Use only your hand to push in or turn the control knobs. Never use tools. If the knobs will not push in or turn by hand, don't try to repair them; call a qualified service technician. Force or attempted repair may result in a fire or explosion.
- D. Do not use this appliance if any part has been under water. Immediately call a qualified service technician to inspect the appliance and to replace any part of the control system and any gas control, which has been under water.

LIGHTING INSTRUCTIONS

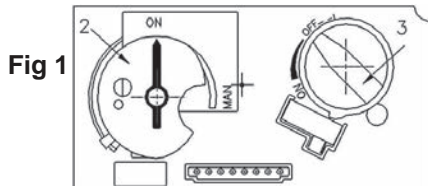

Fig 1

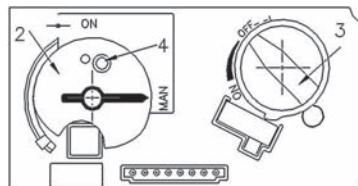
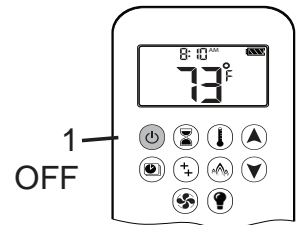





Fig 2





1. STOP! Read the safety information above

2. TO CLEAR ANY GAS, turn main valve off by pressing the  button on remote handset (1). Wait five (5) minutes to clear out any gas, then smell for gas, including near the floor. If you smell gas, STOP! follow "B" in the safety information above on this label. If you don't smell gas, go to the next step.

3. AUTOMATIC IGNITION: MAN-knob (2) in ON position. Ensure Flame Adjustment knob (3) is set to lowest setting (Fig. 1). Locate the pilot (Fig. 3.) inside the firebox.

On the remote control handset, press the  button; a short acoustic signal confirms the start has begun. Further short acoustic signals indicate the ignition process is in progress. When the pilot is lit, the Flame Adjustment knob (3) will automatically rotate to the highest setting. Press the  button on the remote control handset to reduce the flame height.

4. MANUAL IGNITION: MAN-knob (2) in MAN position (Fig. 2).

With the window off, locate the pilot (Fig. 3) inside the firebox. Set Flame Adjustment knob (3) to the lowest setting. Push down the metallic core (4) with a pen or similar instrument; this will establish the pilot gas flow. Light gas at the pilot (5) with a match. Continue holding down metal core (4) for about 10 seconds; after release, pilot should remain lit. If the pilot will not stay lit after several tries, turn the gas control knob (3) to OFF and call your local service technician or gas supplier. Reinstall the window and set the MAN-knob (2) to ON; turn Flame Adjustment knob (3) up or down manually or use the  and  buttons on the remote control handset to adjust the flame height.

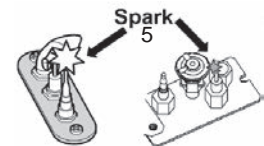



Fig 3

TO TURN OFF GAS TO APPLIANCE

AUTOMATIC SHUT-OFF (using the remote control handset):

Press and hold the  button on the remote control handset to shut-off the main burner gas flow.

Press the  button on remote handset to shut-off the appliance, including pilot flame.

Appendix B—Remote Control Operation

Initial Pairing

Before the remote control can be used with the fireplace, it must be paired. See page 57.

Remote Control Operation

NOTE: Before using the remote control system for the first time, the receiver and the handset must be paired. See the section *Remote Control Initial Pairing* on the first page of this manual.

Main Display

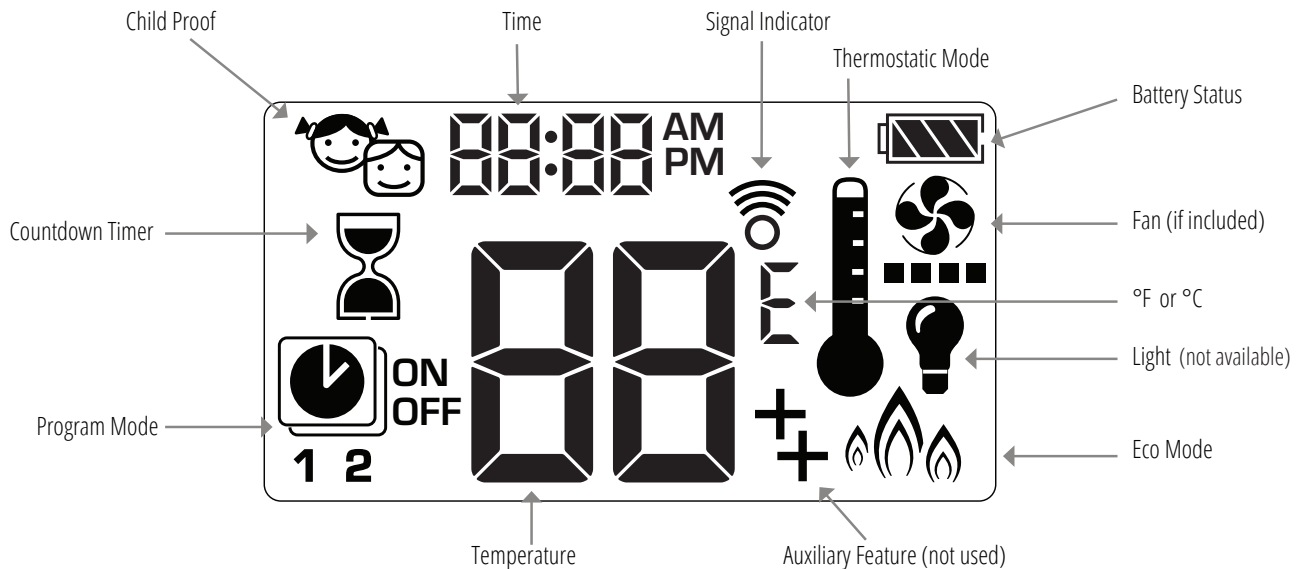

To Turn On Fire

NOTE: When pilot ignition is confirmed, motor automatically turns to maximum flame height.

One-Button lighting (default):

Two-Button lighting: + simultaneously

Press and hold for 4 seconds, until 8 short beeps and a blinking series of lines confirms the start sequence has begun. Release button.

Main gas flows once pilot ignition is confirmed.

Handset automatically goes into manual mode after main burner ignition.

Standby Mode (Pilot Flame)

Press and hold to set appliance to pilot flame.

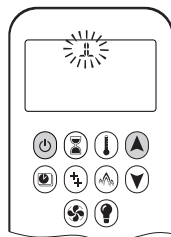
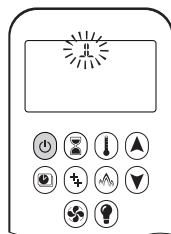

CAUTION: If the pilot does not stay lit after several tries call your local service technician or gas supplier.

To Turn Off Fire

Press to turn OFF.

Note: There is a 2 minute delay after switching off before the next ignition is possible.

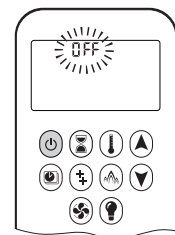

CAUTION: Always check the fire and pilot visually to ensure they are off.

Flame Height Adjustment

To increase flame height, press and hold .

To decrease flame height, press and hold . You may hold the button down until the fire is set to pilot flame only.

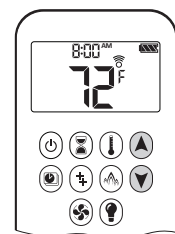



Appendix B—Remote Control Operation

Designated Low Fire and High Fire

To go to low fire, double-click , "LO" is displayed.

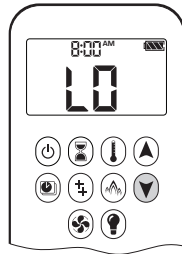
Note: Flame goes to high fire first before going to low fire.



To go to high fire, double-click , "HI" is displayed.

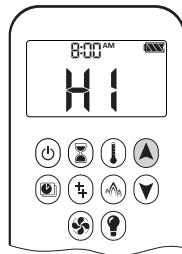

Choosing 1-Button or 2-Button Ignition

On the remote control handset, you can choose a 1-button or 2-button ignition. You can also choose to activate or deactivate some of the functions. By default, the handset is set to a 1-button ignition.

To change from 1-button to 2-button ignition, remove the batteries, wait 10 seconds, reinsert batteries, and immediately when the display flashes, press and hold the  button for 10 seconds. **ON** is displayed and **1** is flashing. When change is complete, **1** changes to **2**.

To change from 2-button to 1-button ignition, proceed the same as above. **ON** is displayed and **2** is flashing. When change is complete, **2** changes to **1**.

Deactivating or Activating Functions

These functions are active by default, but can be deactivated at any time:

- Child Proof
- Program Mode
- Thermostatic Mode
- Eco Mode
- Circulating Fan Operation
- Countdown Timer

To deactivate functions:



1. Install batteries. All icons are displayed and flashing.
2. While the icons are flashing, press the relevant function button and hold for 10 seconds.
3. The function icon will flash until deactivation is complete. Deactivation is complete when the function icon and two horizontal bars () are displayed.

Note: If a deactivated button is pressed, there is no function, and the two horizontal bars are displayed.

To activate functions:

1. Install batteries. All icons are displayed and flashing.
2. While the icons are flashing, press the relevant function button and hold for 10 seconds.
3. The function icon will continue to flash until activation is complete, and then turn solid. Activation is complete when the function icon is displayed.















Setting Celsius or Fahrenheit

To change between °C and °F, press and hold  +  simultaneously.

Note : °C = 24-hour clock
°F = 12-hour clock



Setting the Time

1. Press  +  simultaneously. **Day** flashes.
2. Press  +  to select a number to correspond with the day of the week.
 - 1 = Monday
 - 2 = Tuesday
 - 3 = Wednesday
 - 4 = Thursday
 - 5 = Friday
 - 6 = Saturday
 - 7 = Sunday
3. Press  +  simultaneously. **Hour** flashes.
4. To select hour press  or .
5. Press  +  simultaneously. **Minutes** flash.
6. To select minutes press  or .
7. To confirm, press  +  simultaneously or wait.

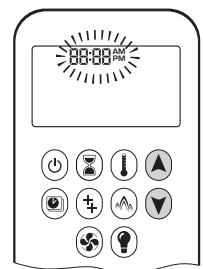

Appendix B—Remote Control Operation

Child Proof

Your handset can be set to lock out all commands to the fireplace, except OFF.

To turn Child Proof ON:

1. Press and hold + simultaneously.
2. is displayed. Child Proof is now active.

To turn Child Proof OFF:

1. Press and hold + simultaneously.
2. disappears. Child Proof is now inactive, and the handset has full function.

Countdown Timer

You can set your fireplace to automatically turn off at the end of a timer.

To set a Countdown Timer:

1. Press and hold until is displayed.
Hour flashes.
2. Press or to select Hour.
3. To confirm, press .
- Minutes** flash.
4. Press or to select Minutes.
5. To confirm, press or wait.

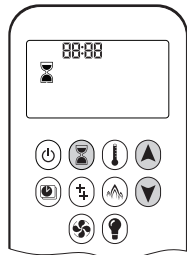

To turn off a Countdown Timer:

1. Press , and the countdown disappears.

Note: The Countdown Timer only works in Manual, Thermostatic, and Eco modes. Maximum countdown time is 9 hours and 50 minutes.

Light/Dimmer Operation (not available)

Circulating Fan Operation (if installed)

Setting:

1. Press and hold until flashes.
2. Press to increase or to decrease fan speed.
3. To confirm setting, either press or wait. is displayed.

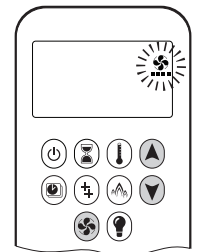

Off:

Press until all 4 speed level bars disappear.

Note: When setting, if the fan was not switched off after last use, it starts automatically 4 minutes after ignition at maximum speed, and goes to the last set level after 10 seconds. The fan stops 10 minutes after the gas is OFF or at pilot.

Appendix B—Remote Control Operation

Modes of Operation

Thermostatic Mode

The room temperature is measured and compared to the set temperature. The flame height is automatically adjusted to achieve the set temperature.

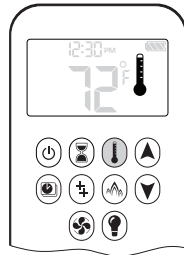

Program Mode

The temperature is controlled by Programs 1 and 2, each of which can be set to go on and off at specific times, at a set temperature.



Eco Mode

Flame height modulates between high and low. If the room temperature is lower than the set temperature, the flame height stays on high for a longer period of time. If the room temperature is higher than the set temperature, the flame height stays on low for a longer period of time. One cycle lasts approximately 20 minutes.





 If any of the above modes (Thermostatic, Program, or Eco) are engaged by the MyFire app over WiFi, the handset will display **APP**.

Manual Mode

The on/off status of the fireplace, as well as flame height, are manually controlled by the user.





Thermostatic Mode

On:

Press .  is displayed. Preset temperature displays briefly, followed by the room temperature.





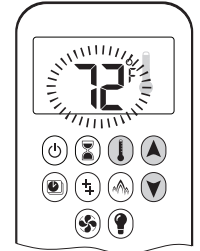

Setting Desired Temperature:

1. Press and hold  until  is displayed and set temperature flashes.
2. To adjust set temperature, press  or .
3. To confirm, press  or wait.



Off:

1. Press .
2. Press  or  to go to Manual Mode.
3. Press  to go to Program Mode.
4. Press  to go to Eco Mode.





Program Mode

On:

Press . , 1 or 2, ON or OFF are displayed.





Off:

1. Press , , or  to go to Manual Mode.
2. Press  to go to Thermostatic Mode.
3. Press  to go to Eco Mode.

Note: The set temperature for Thermostatic Mode is the temperature for the ON time in Program Mode. Changing the Thermostatic Mode set temperature also changes the ON time temperature in Program Mode.

Default Settings:

- ON TIME (Thermostatic) TEMPERATURE: 70°F / 21°C
- OFF TIME TEMPERATURE: “ ” (pilot flame only)

Appendix B—Remote Control Operation

Temperature Setting:

1. Press and hold until flashes. **ON** and set temperature (set in Thermostatic Mode) is displayed.
2. To continue, press or wait. **OFF** displayed, temperature flashes.
3. Select off temperature by pressing or .
4. To confirm, press .

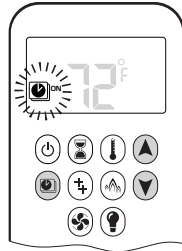

Note: The on (Thermostatic) and off set temperatures are the same for each day.

Day Setting:

1. **ALL** flashes. Press or to choose between:
 - **ALL** = same settings ON-OFF every day
 - **SA:SU** = same settings ON-OFF Saturday and Sunday
 - **1, 2, 3, 4, 5, 6, 7** = daily timer—unique ON-OFF settings for a single day of the week, for multiple days of the week or for every day of the week.
2. To confirm, press .

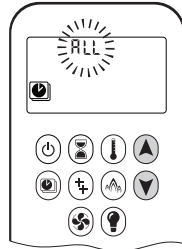

ALL Selected (same settings every day)

On Time Setting (PROGRAM 1)

1. **1, ON** are displayed. **ALL** is displayed briefly. Hour flashes.
2. To select hour, press or .
3. To confirm, press . **1, ON** are displayed. **ALL** displayed briefly. Minutes flash.
4. To select minutes, press or .
5. To confirm, press .

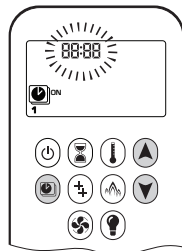

Off Time Setting (PROGRAM 1)

1. **1, OFF** are displayed. **ALL** is displayed briefly. Hour flashes.
2. To select hour, press or .
3. To confirm, press . **1, OFF** are displayed. **ALL** displayed briefly. Minutes flash.
4. To select minutes, press or .
5. To confirm, press .

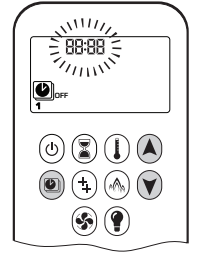

Note: Either continue to PROGRAM 2 and set ON and OFF times or stop programming at this point, and PROGRAM 2 remains deactivated.

Note: PROGRAM 1 and 2 use the same ON (Thermostatic) and OFF temperatures. Once a new ON (Thermostatic) and/or OFF temperature has been set, that temperature becomes the new default setting.

Note: ON and OFF times programmed for PROGRAM 1 and PROGRAM 2 become the new default times.

The batteries must be removed to clear the PROGRAM 1 and PROGRAM 2 ON and OFF times and temperatures.

SA:SU (same settings Saturday and Sunday) or 1, 2, 3, 4, 5, 6, 7 (different settings on different days)

- Set on time and off time using the same procedure as "ALL Selected" above.
- Waiting to finish setting.

Eco Mode

On:

Press button to enter Eco Mode. is displayed.

Flame height modulates between high and low every 20 minutes.

Off:

Press button to exit Eco Mode. disappears.



Appendix B—Remote Control Operation

Low Battery Indication

⚠ CAUTION: Do not use a screwdriver or other metallic object to remove the batteries from the battery holder or the handset. This could cause a short circuit.

Handset

The battery icon  will show when the battery needs to be replaced. Replace with two 1.5 V AAA alkaline batteries.

Receiver

Frequent beeps for 3 seconds when the motor turns indicate the batteries in the battery holder need to be replaced. Replace with four 1.5 V AA alkaline batteries.

Automatic Shut Off

Countdown Timer

At the end of countdown time period, the fire turns off. The Countdown Timer only works in Manual, Thermostatic, and Eco Modes. Maximum countdown time is 9 hours and 50 minutes.

Low Battery Receiver

With low battery power in the battery holder, the system shuts off the fire completely. (This will not happen if the power is completely interrupted.)

Seven Day Shut Off

The system shuts off the fire completely if there is no change in flame height for 7 days.

Automatic Turn Down

3 Hour No Communication Function

The valve will turn to pilot flame if there is no communication between the handset and receiver for a 3-hour period. The fire will continue to function normally when communication is restored.

Appendix B—Remote Control Operation

Error Codes

In the event of an error condition with the handset or fireplace, the handset will display an error code.

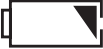
Failure Code	Message on Handset	Duration of Display	Symptom	Possible Cause
F04	F04	4 sec	<ul style="list-style-type: none"> No pilot flame within 30 sec Note: after 3 failed ignition sequences, F06 shown 	<ul style="list-style-type: none"> No gas supply Air in pilot supply line No spark Reversed polarity in thermocouple wiring
F06	F06	4 sec	<ul style="list-style-type: none"> 3 failed ignition sequences in 5 minutes Fire is not responding, no pilot flame 	<ul style="list-style-type: none"> No gas supply Air in pilot supply line No spark Reversed polarity in thermocouple wiring Incorrect pilot orifice if valve has been converted from LPG to NG or vice versa
F07	Low battery symbol 	Permanent	<ul style="list-style-type: none"> Battery icon flashes on handset display 	<ul style="list-style-type: none"> Low battery in handset
F09	F09	4 sec	<ul style="list-style-type: none"> Fire is not responding No electronic control of fire 	<ul style="list-style-type: none"> Down arrow button (▼) was not pressed during pairing Receiver and handset are not synced
F46	F46	4 sec	<ul style="list-style-type: none"> Fire is not responding Intermittent response No electronic control of fire 	<ul style="list-style-type: none"> No or bad connection between receiver and handset No power at receiver (batteries low) Low communication range (mains adapter faulty, handset not communicating with receiver)

Appendix C—Wall Switch Operation

The Wall Switch can be used to control your fireplace. You can turn the pilot on or off and you can increase or decrease the flame height.

Note that the thermostat and programming functions are not available with the wall switch.



Adjusting Flame Height

Press and hold large flame  button to gradually increase flame height.

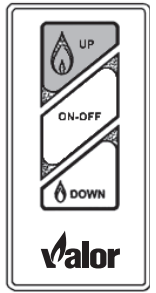

Turning Appliance ON and OFF

Press ON-OFF button once to light pilot. Press again to shut off pilot.

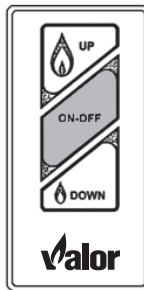

Press and hold small flame  button to gradually decrease flame height.

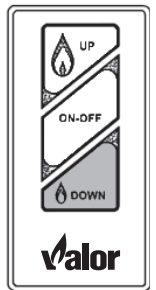

Appendix D—HeatShift System

HeatShift™ System

Planning Installation: Linear with HeatShift™

Instructions for use with the following **Valor Heater Models: 1500, 1600, 1700 and 1800 J or K**
Incompatible with earlier models: 1500I, 1600I, and 1700I

Application

The HeatShift™ system redistributes the warm air flow away from the fireplace opening to a more desirable location using natural convection without use of a fan.

Plenums LKD1, LDK3, LDK4 or LDK9: the warm air flow is relocated to a position higher up the wall, out the sidewalls, or even to an adjacent room.

Termination Plates LDK7: the warm air flow is discharged through a gap (min. 2-1/2" [64 mm]) between the wall above the fireplace and the ceiling. **LDK7's discharge opening must be located in the same room as the fireplace.**

The result is much cooler wall temperatures above the fireplace opening for locating televisions, artwork, etc.

The 1595CFK or 1595CFKV2 Circulating Fan Kit are not recommended when installing the HeatShift system.

Any kit, LDK1, LDK3, LDK4, LDK7 or LDK9 may be used with compatible model fireplaces L1, L2 or L3 listed above.

As a further option, the warm airflow may be extracted away from the duct kit plenum (**LDK1 and LDK4 ONLY**) by connecting a 1270RBK HeatSplit Remote Blower Kit to the duct kit plenum.

This kit is compatible with the listed fireplaces only. Earlier version fireplaces will not accept the addition of this kit.

Note: These instructions are to be used in conjunction with instructions regarding fireplace installation in this manual.

WARNING

All fireplaces listed above require the removal of the internal convection baffle for this system to function properly—read instructions carefully!

The use of this kit will permit lower mantel clearances to be used—see *Combustible Mantel Clearances* in this Appendix. These lower mantel clearances **must ONLY be used when the HeatShift system is installed and the internal convection baffle has been removed.**

Approvals

The LDK1, LDK3, LDK4, LDK7 and LDK9 duct kits are CSA approved for use only with Valor Series fireplaces listed above—DO NOT use with any other models.

This HeatShift system may also be used to reduce wall surface temperatures on approved outdoor installations.

5-inch [127 mm] diameter duct used with this kit must be metal and meet requirements of UL-181 Class 1 Air Duct. Flexible aluminum duct is acceptable provided it meets the UL-181 Class 1 requirements.

WARNING

DO NOT cover or place objects in front of or on top of air outlet(s). AVOID locating outlet within 7 feet [2134 mm] above floor level as discharge temperatures are hot!

WARNING

When placing discharge close to ceilings, staining or streaking may occur on light colored ceilings due to any dust, etc. in air flow; placing plenum(s) lower on the wall will help reduce the possibility of staining or streaking.

Appendix D—HeatShift System

Kits

There are 5 kits to choose from:

- LDK1— Plenum, 48" [1220 mm]
- LDK3— Plenums (2), includes grilles, 14" [356 mm]
- LDK4— Plenum, 38" [966 mm]
- LDK7— Duct Termination Plates (2)—for wall valance discharge ONLY
- LDK9— Plenum, 30" [762 mm]

Kits Contents

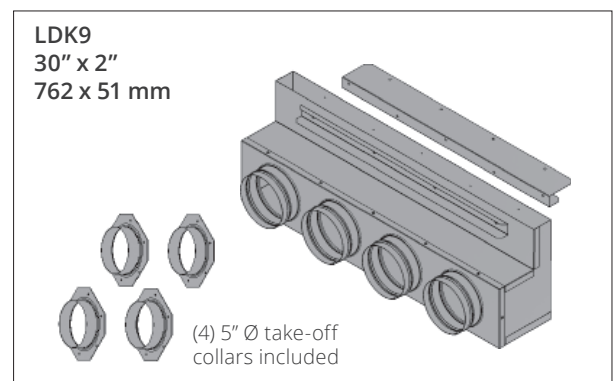
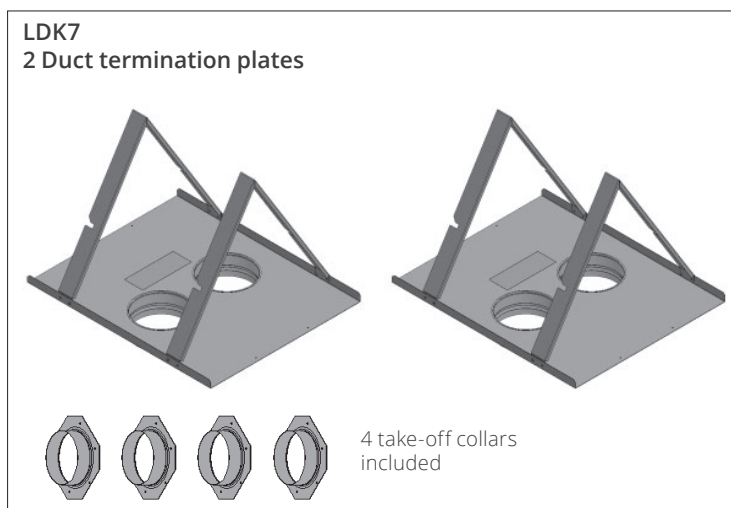
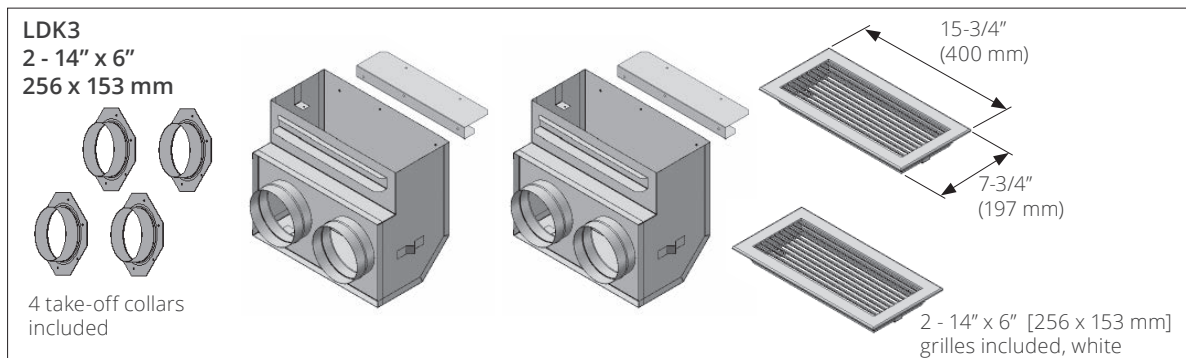
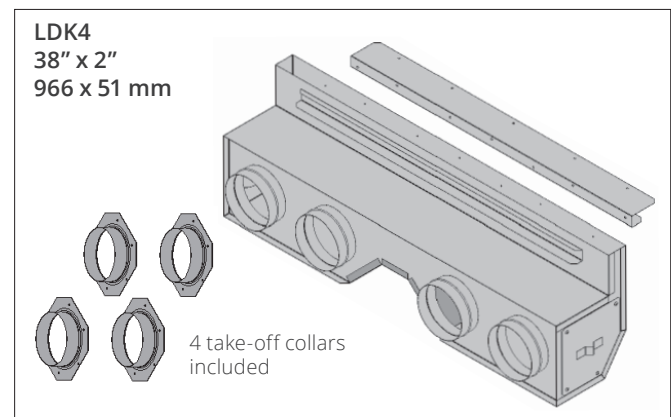
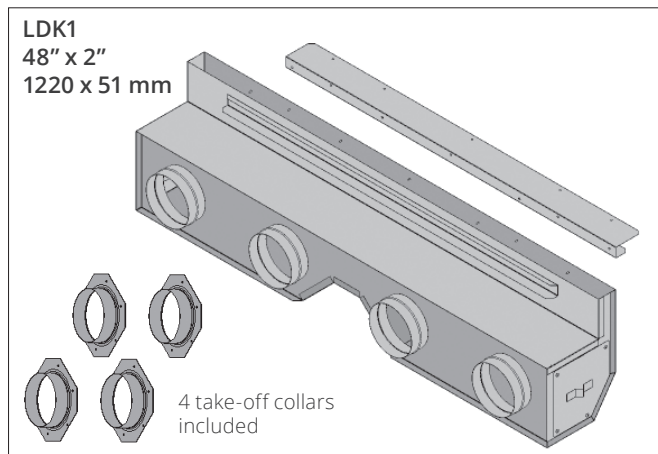

Appendix D—HeatShift System

Optional accessories

- LDK2—48" [1220 mm] Finishing Frame, to use with LDK1
- LDK5—38" [966 mm] Finishing Frame, to use with LDK4
- LDK6— 5" [127 mm] dia Aluminum 2-ply Flex Kit—
2 x 10'-0" [3048 mm] lengths, may be cut to required length
- LDK10—30" [732 mm] Finishing Frame, to use with LDK9

Kits Contents

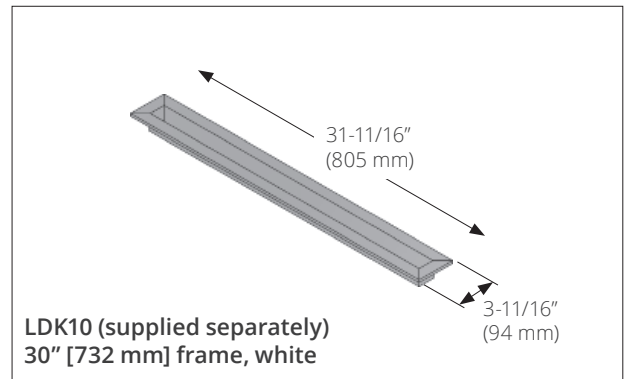
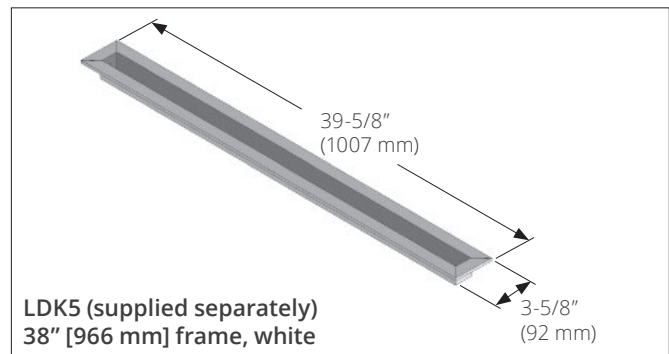
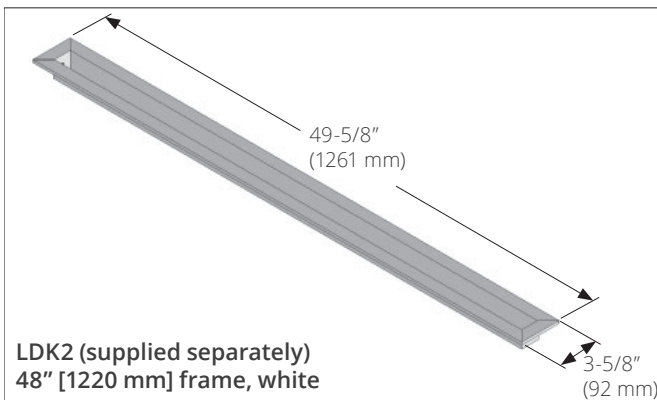

Appendix D—HeatShift System

Suggested Configurations Not to scale

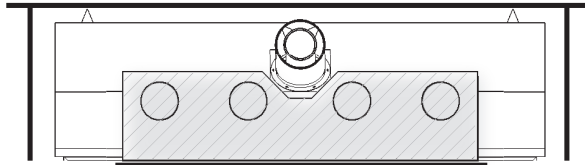

Front wall outlet using LDK1, LDK4 or LDK9

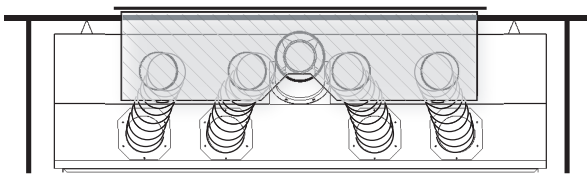

Rear wall outlet using LDK1, LDK4 or LDK9
Note: Fireplace vent may conflict with plenum. Offset vent around plenum.

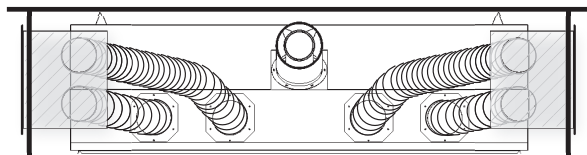

Side wall outlets using LDK3

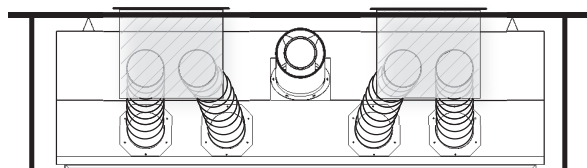

Rear wall outlets using LDK3

Note: Vertical venting straight off 1600K heater will NOT clear 38" (LDK4) or 48" (LDK1) plenums without offsetting vent around plenum.

Note: Take-off collars staggered, 2 per side

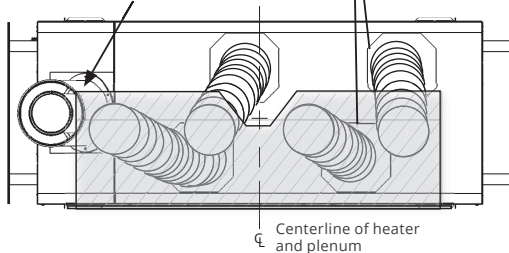

Centerline of heater and plenum

1600K L1 see-thru using LDK1, LDK4 or LDK9

Note - When using LDK7, the discharge opening must be located in the same room as the fireplace.

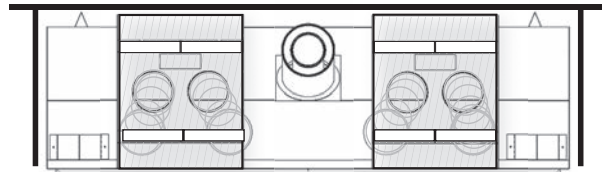

With LDK7

Corner installations

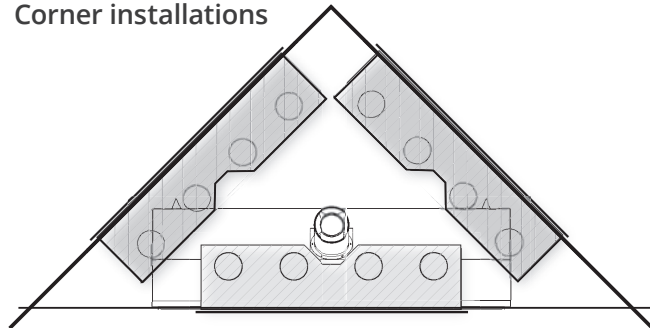

WARNING

The plenum duct kits are approved for horizontal discharge ONLY. The termination duct plates are approved for vertical upward discharge ONLY. DO NOT install plenum or termination plates in floor or ceiling. DO NOT COVER OR PLACE objects in front of or on top of air outlet(s). AVOID locating outlet within 7 feet [2134 mm] of the floor level as discharge air temperatures are hot!

DO NOT DISCHARGE THROUGH EXTERIOR WALLS!

NOTE This duct kit may also be used for outdoor installations where reduced wall surface temperatures above the unit are desired. The discharge grilles must be located under the weatherproof enclosure described in the GV60CKO Outdoor Fireplace Conversion Kit instructions.

Appendix D—HeatShift System

Overview (applies to LKD1, LDK3, LDK4 and LDK9 kits)

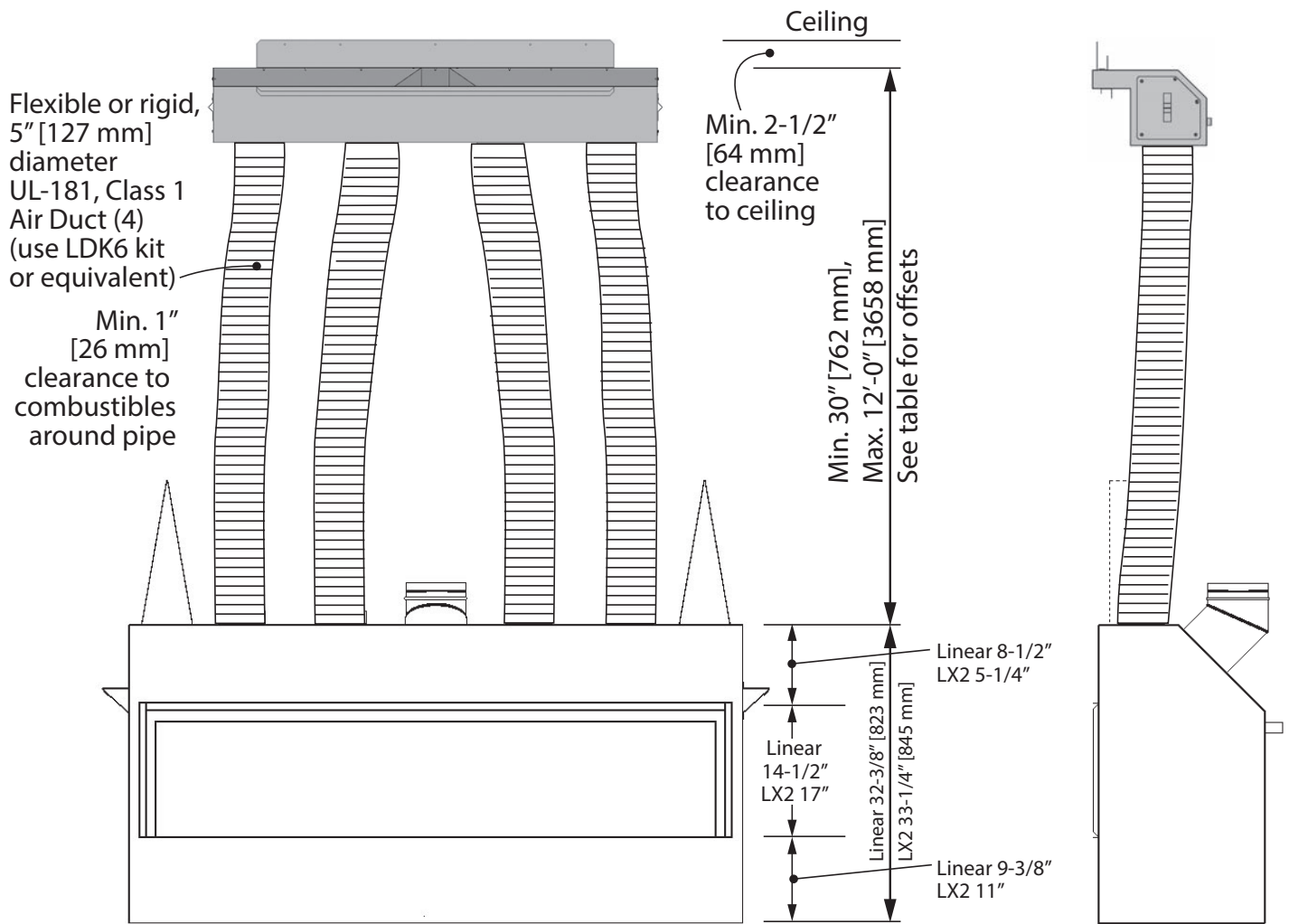

Appendix D—HeatShift System

Overview (applies to LDK7)

NOTE Discharge opening must be located in the same room as fireplace when using LDK7.

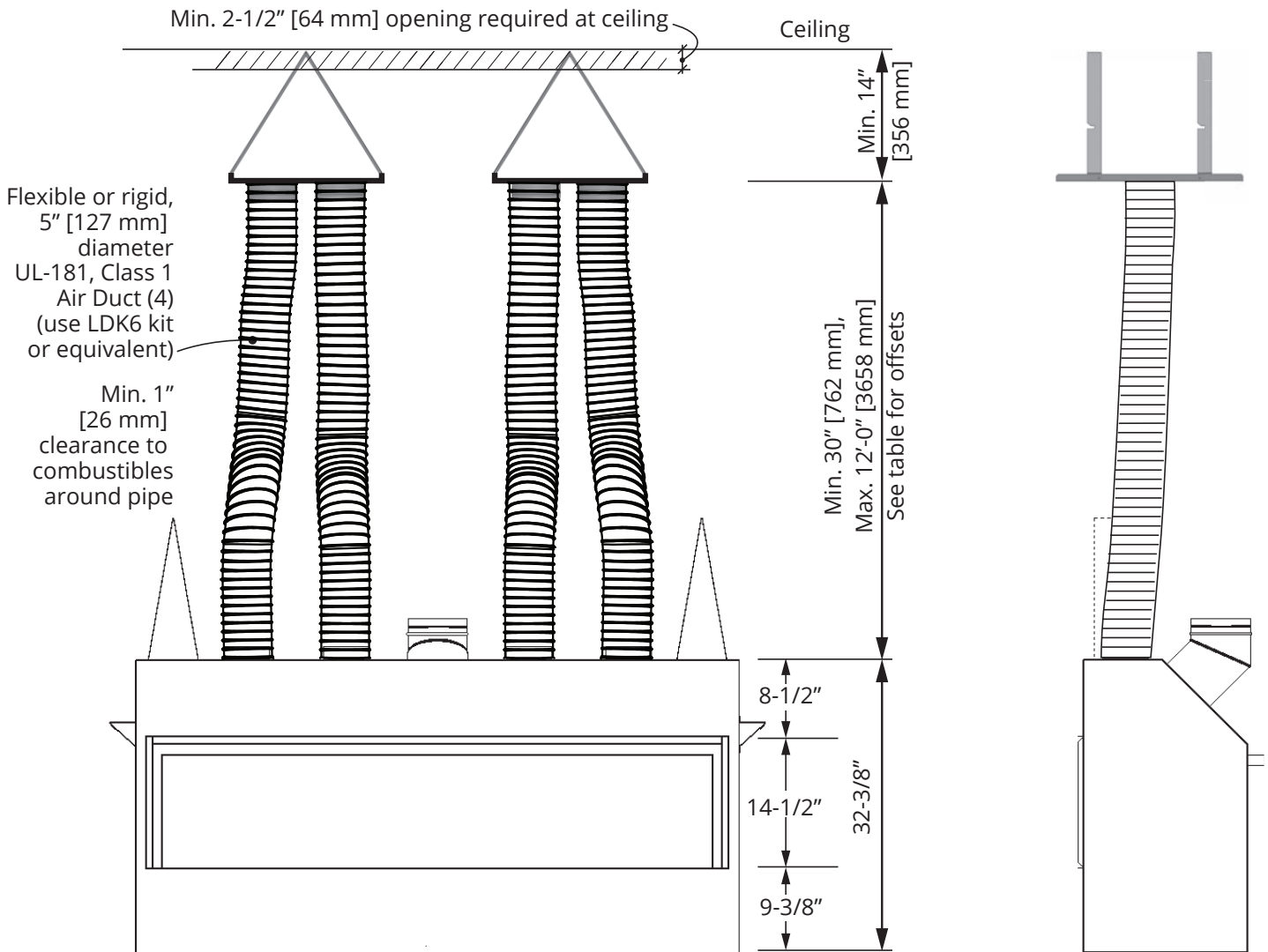

Appendix D—HeatShift System

Y Vertical Rise	X Max. Allowable Horizontal Offset
30" 762 mm	24" 610 mm
36" 914 mm	36" 914 mm
42" 1067 mm	48" 1219 mm
48" 1219 mm	60" 1524 mm
54" 1372 mm	72" 1829 mm
60" 1524 mm	84" 2134 mm
66" 1676 mm	96" 2438 mm
12'-0" 3.7 m	96" Max.

With Plenum

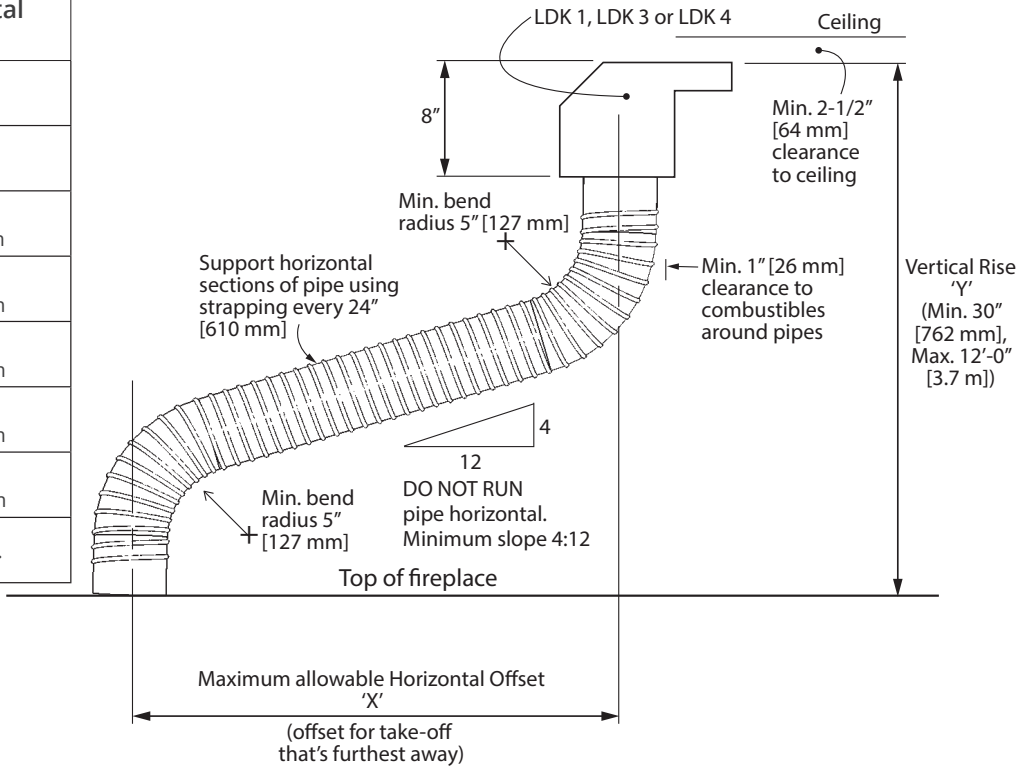

With Plates

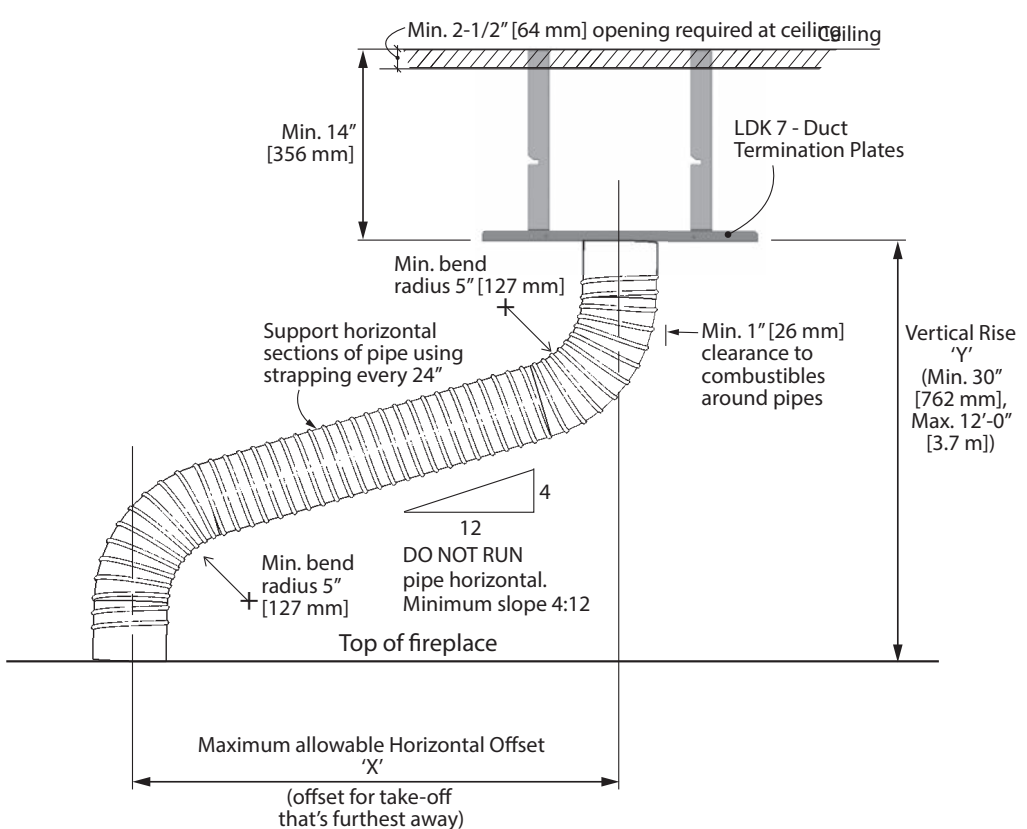

Appendix D—HeatShift System

Plenum Dimensions

LDK 1

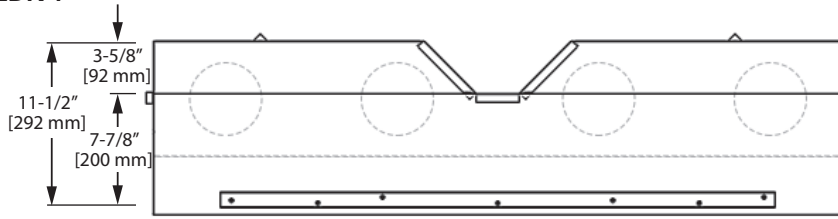

Top View

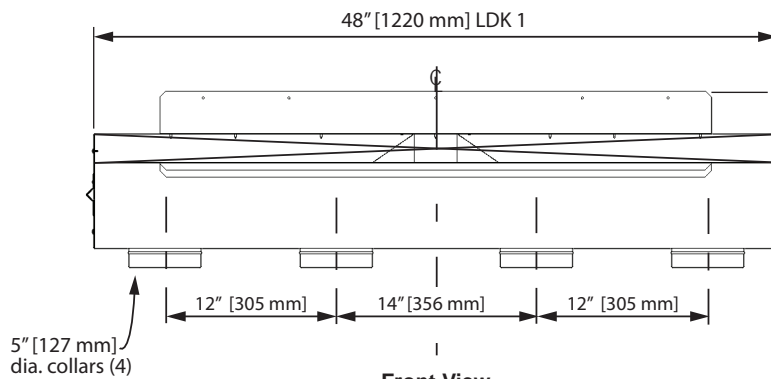

Front View

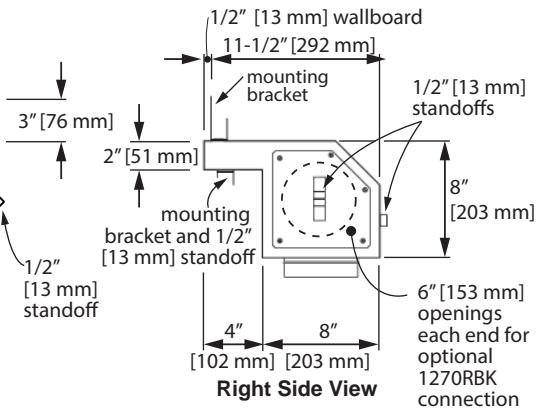

Right Side View

LDK 4

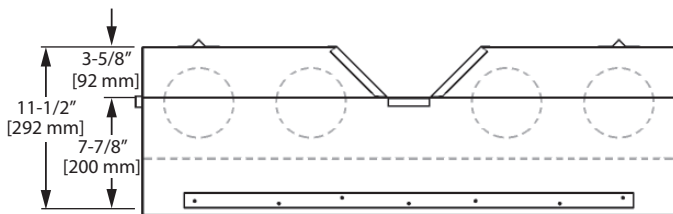

Top View

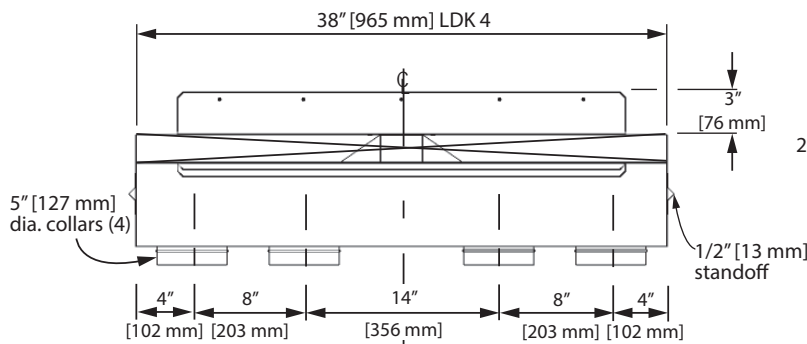

Front View

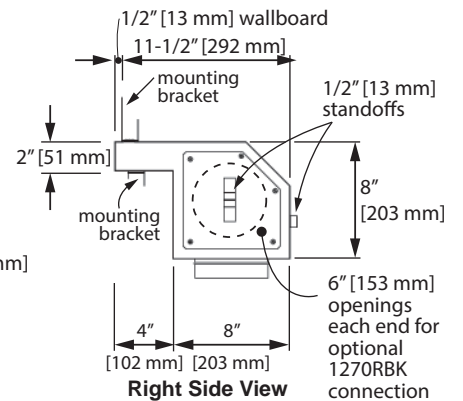

Right Side View

Appendix D—HeatShift System

Plenum Dimensions (cont'd)

LDK 3

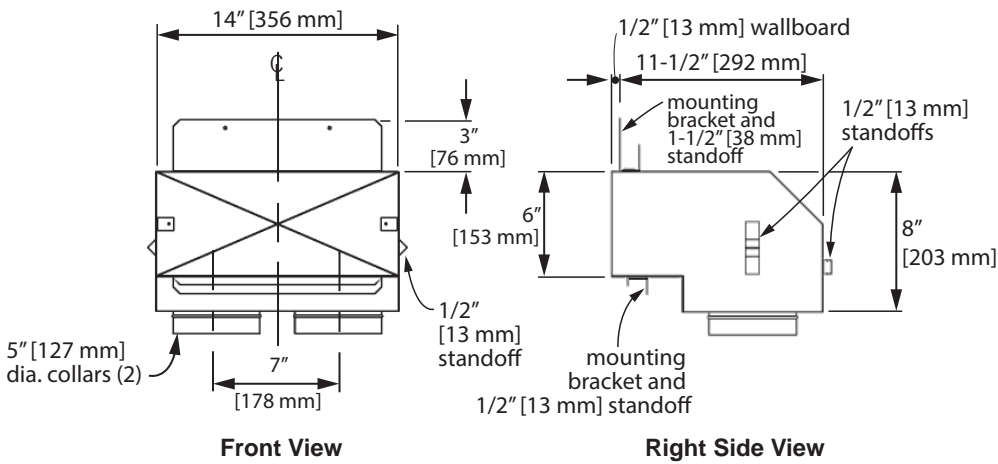

LDK 9

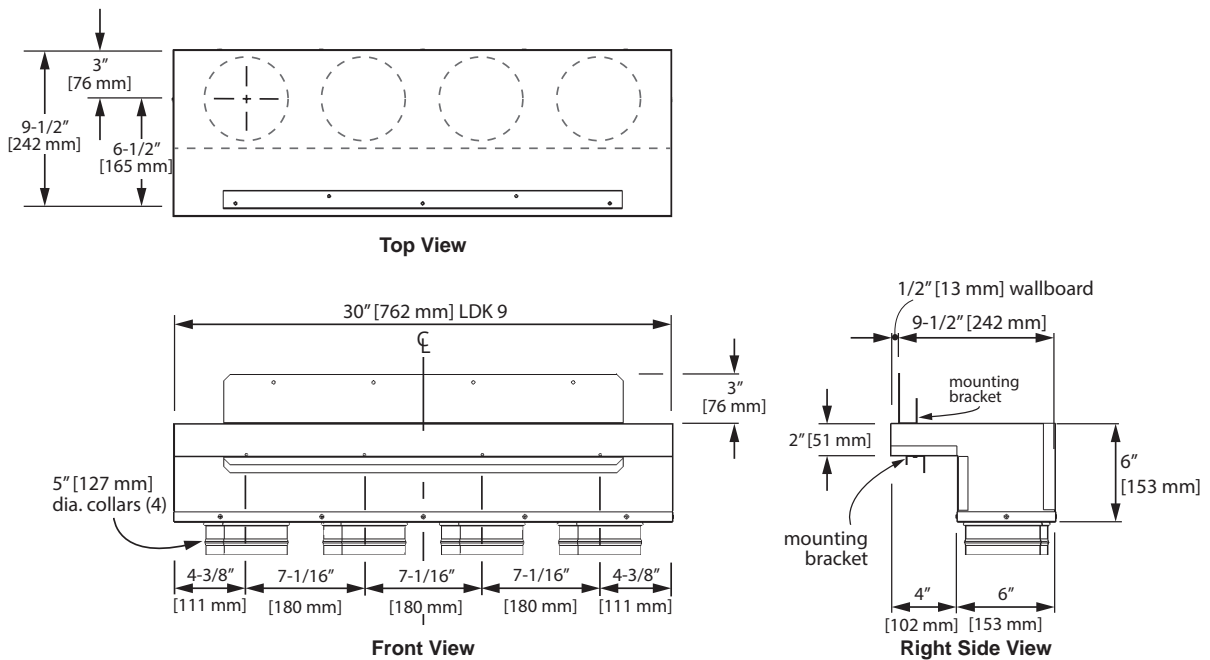

Appendix D—HeatShift System

LDK7 Plates Dimensions

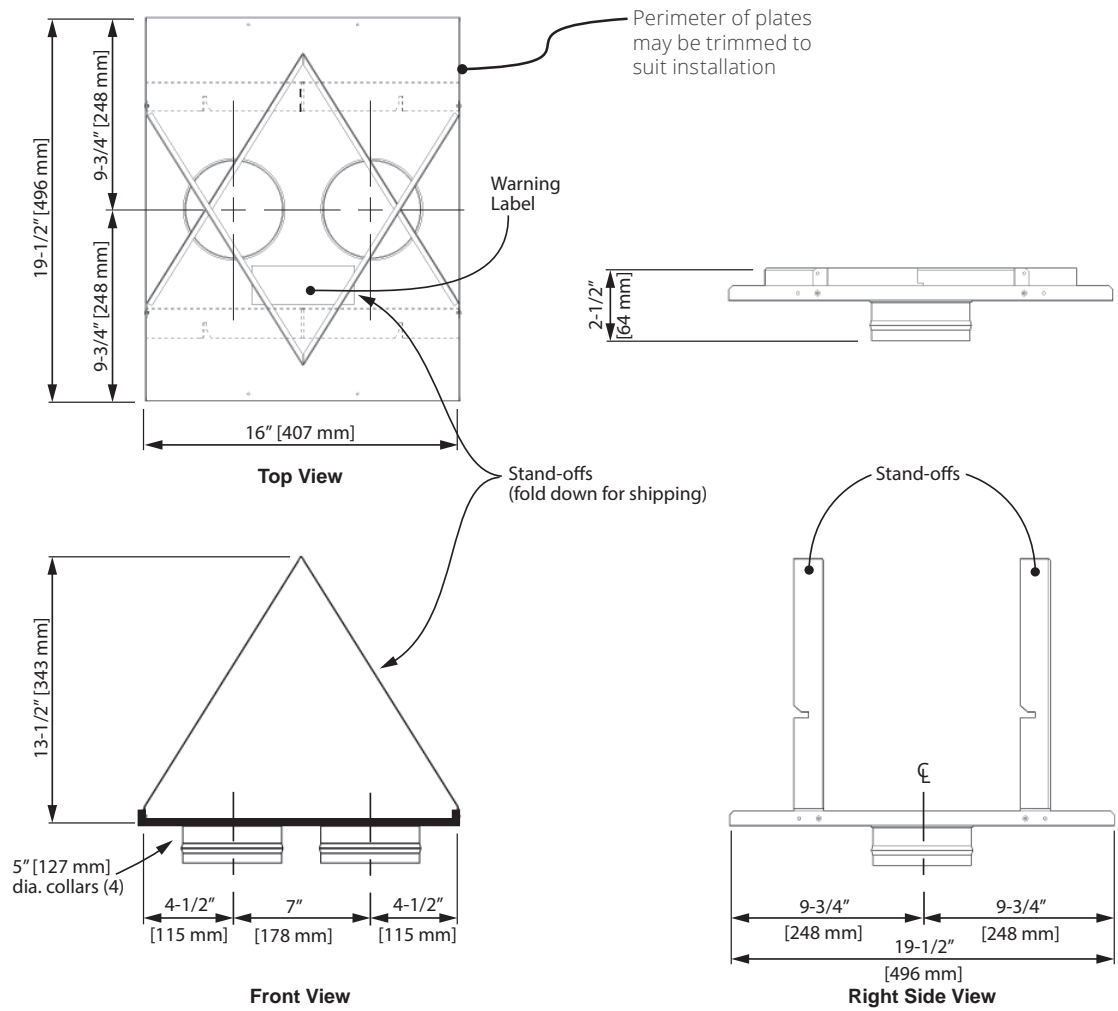

Appendix D—HeatShift System

Rough Frame Openings

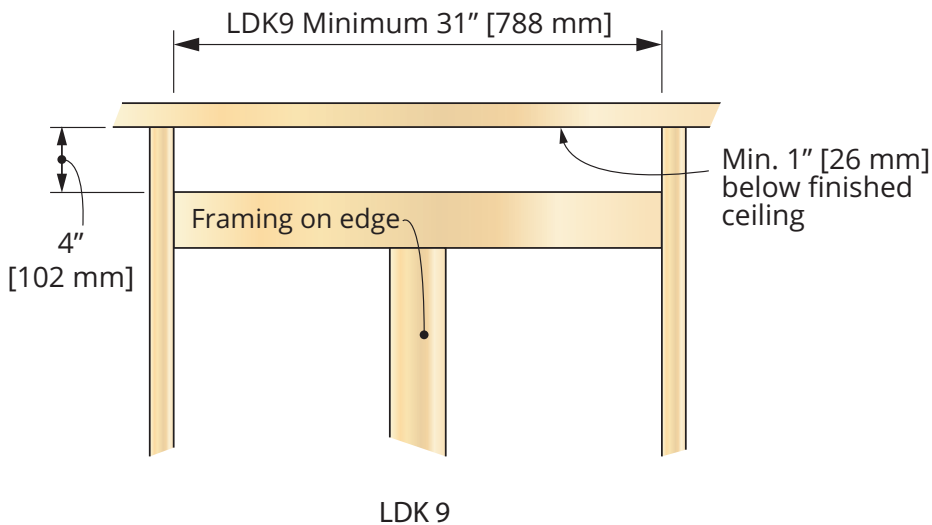
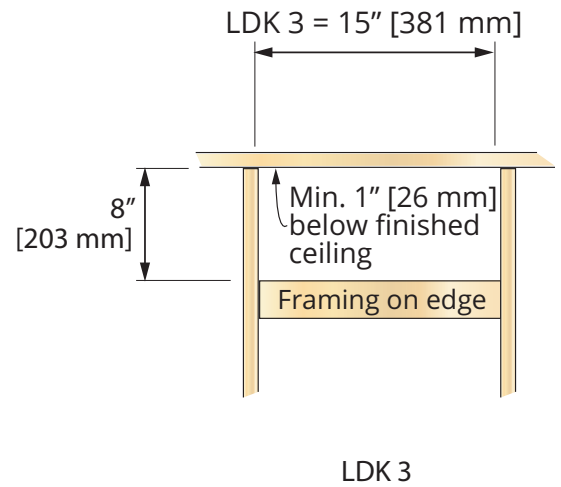
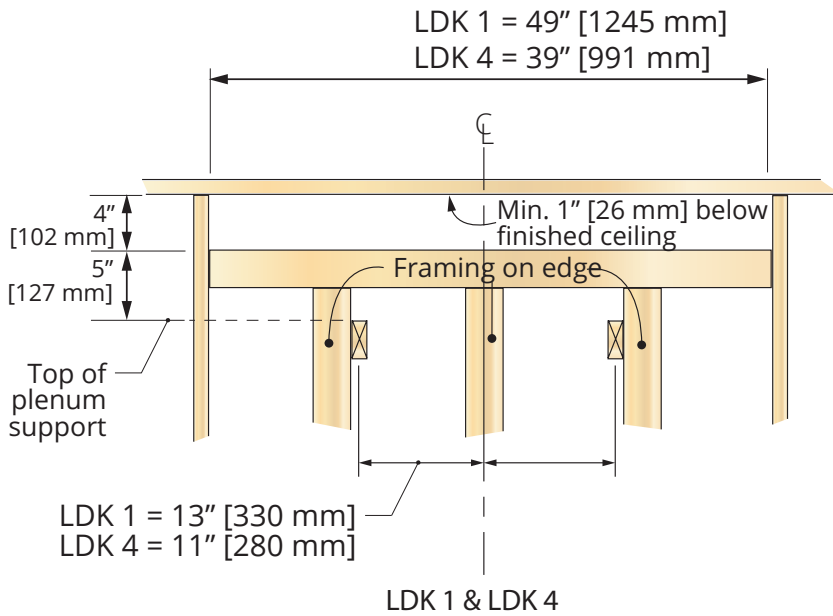

Appendix D—HeatShift System

Framing and Clearances—Plenums, front view

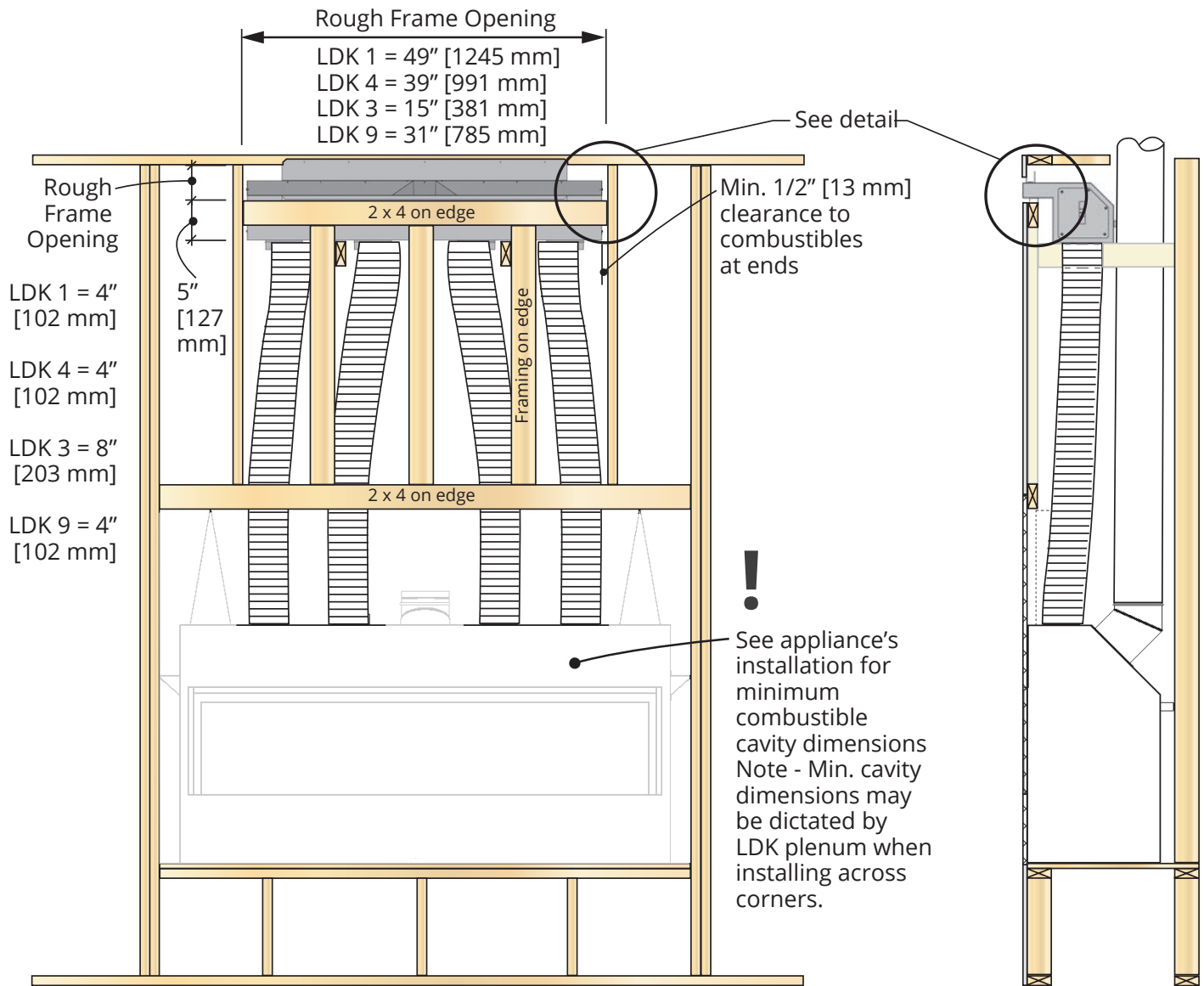

Appendix D—HeatShift System

Framing and Clearances—Plenums, side view

LDK 1 & 4

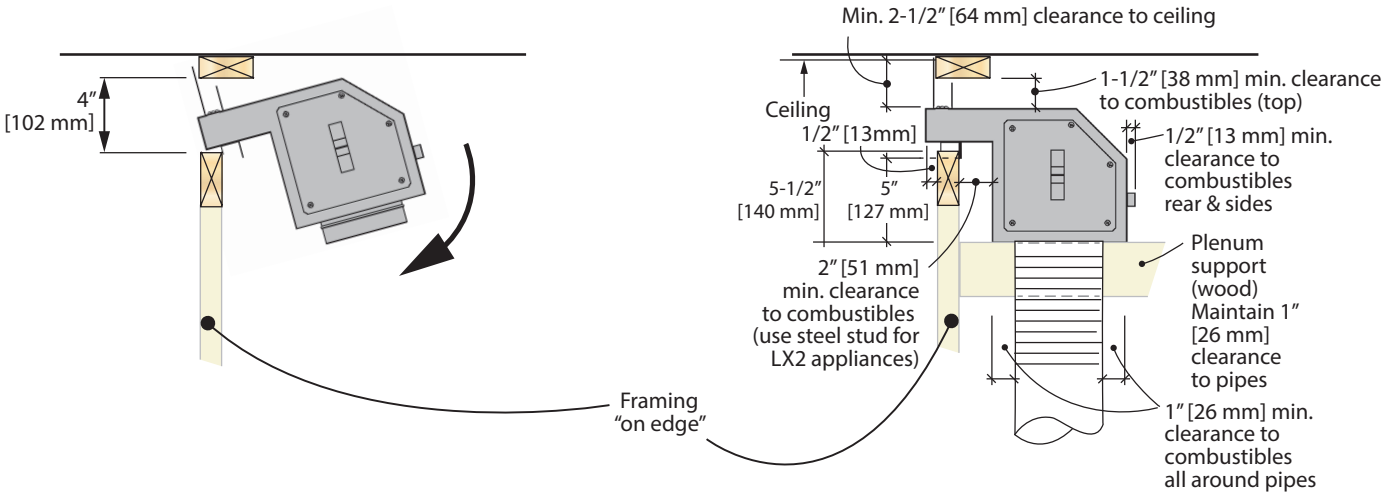

LDK 3

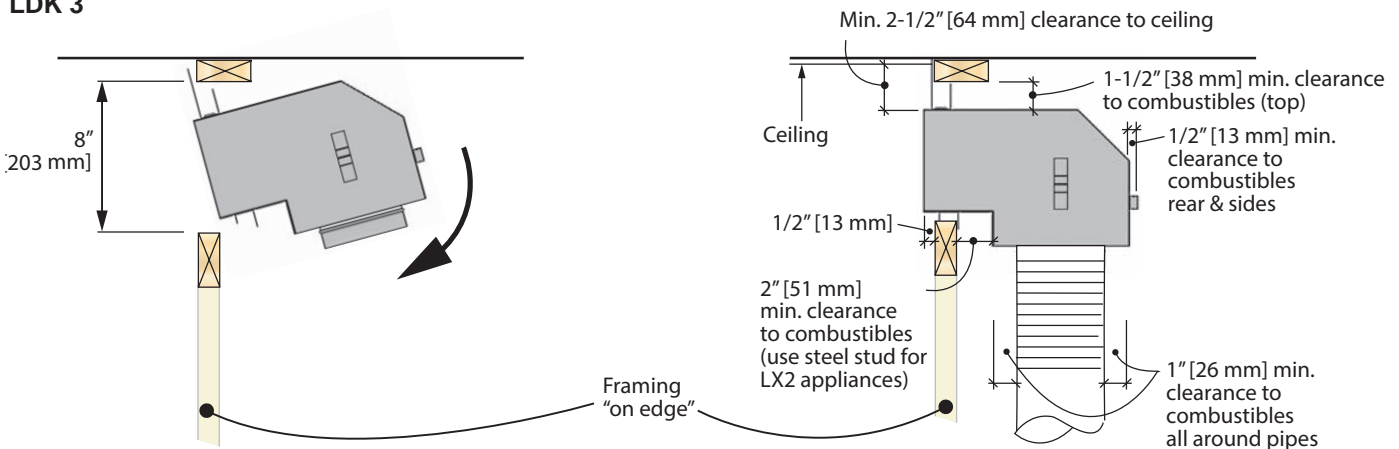

LDK 9

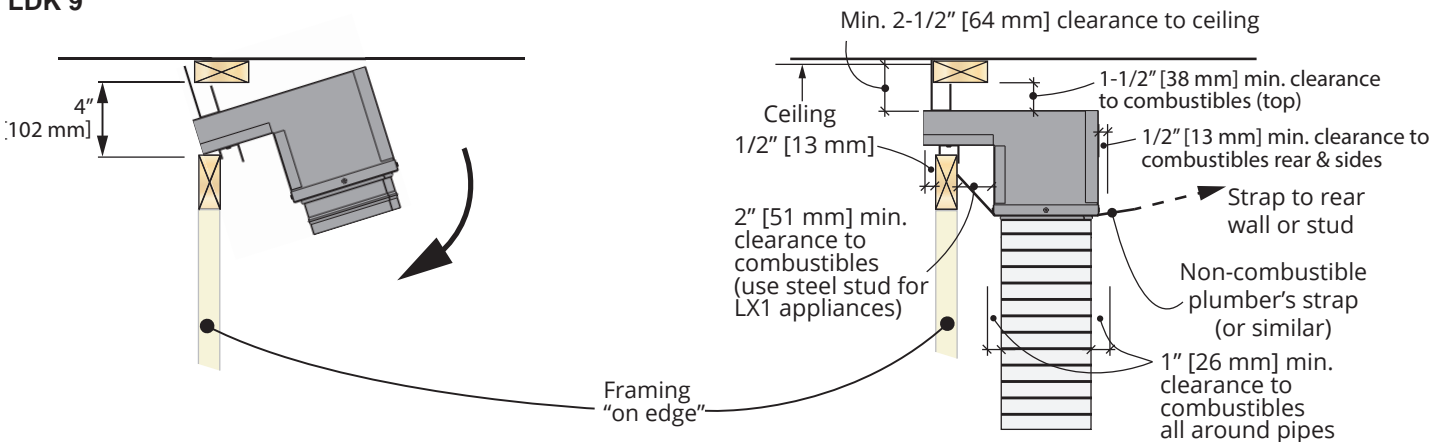

Appendix D—HeatShift System

Wall Valance Discharge Opening using LDK7—Duct Termination Plates

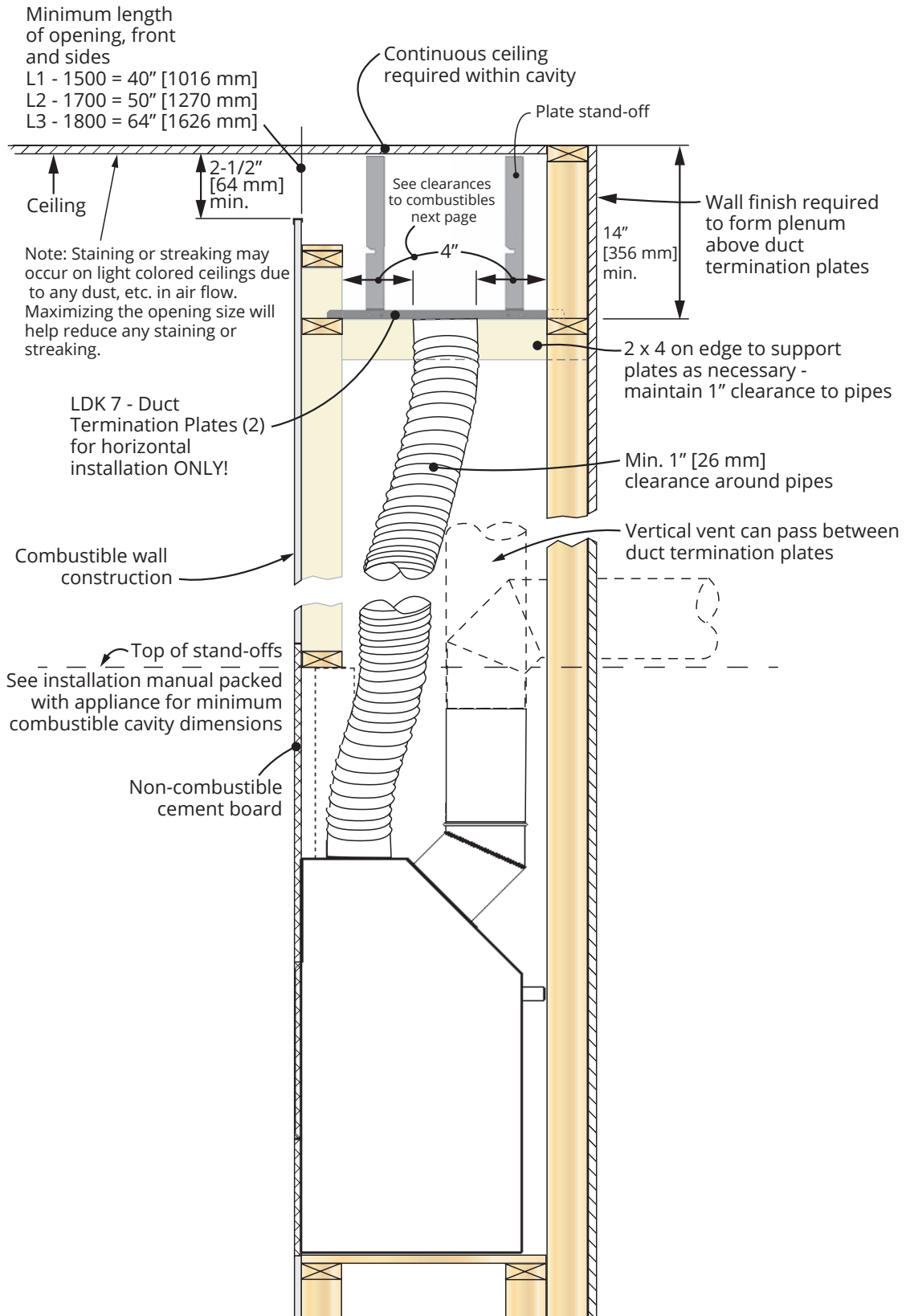

Appendix D—HeatShift System

LDK7 Clearances to Combustibles

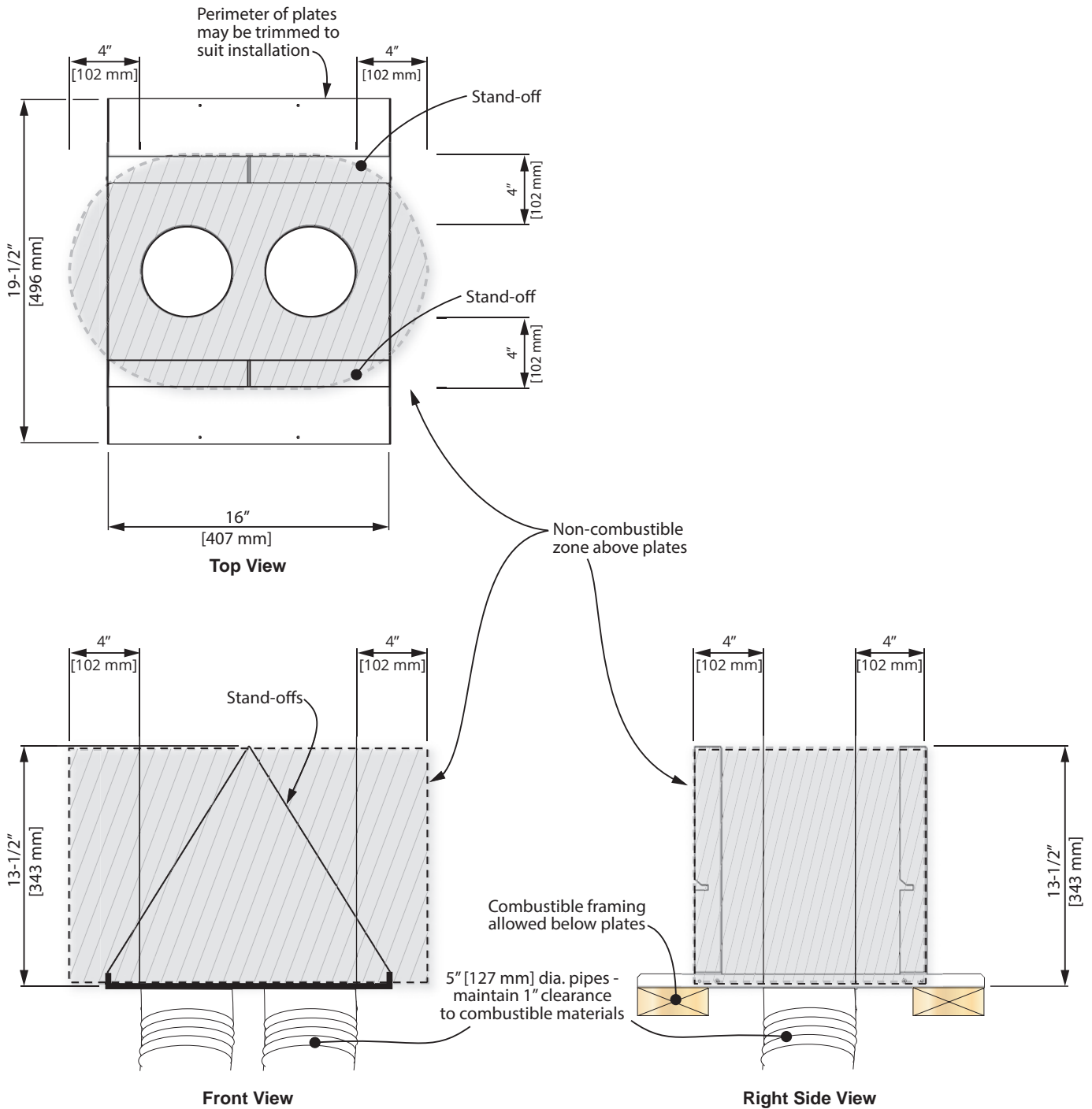

Appendix D—HeatShift System

LDK Duct Kit LDK 1, LDK 4 with optional 1270RBK HeatSplit Remote Blower Kit
(not approved with outdoor installations)

HeatShift™ + HEATSPLIT

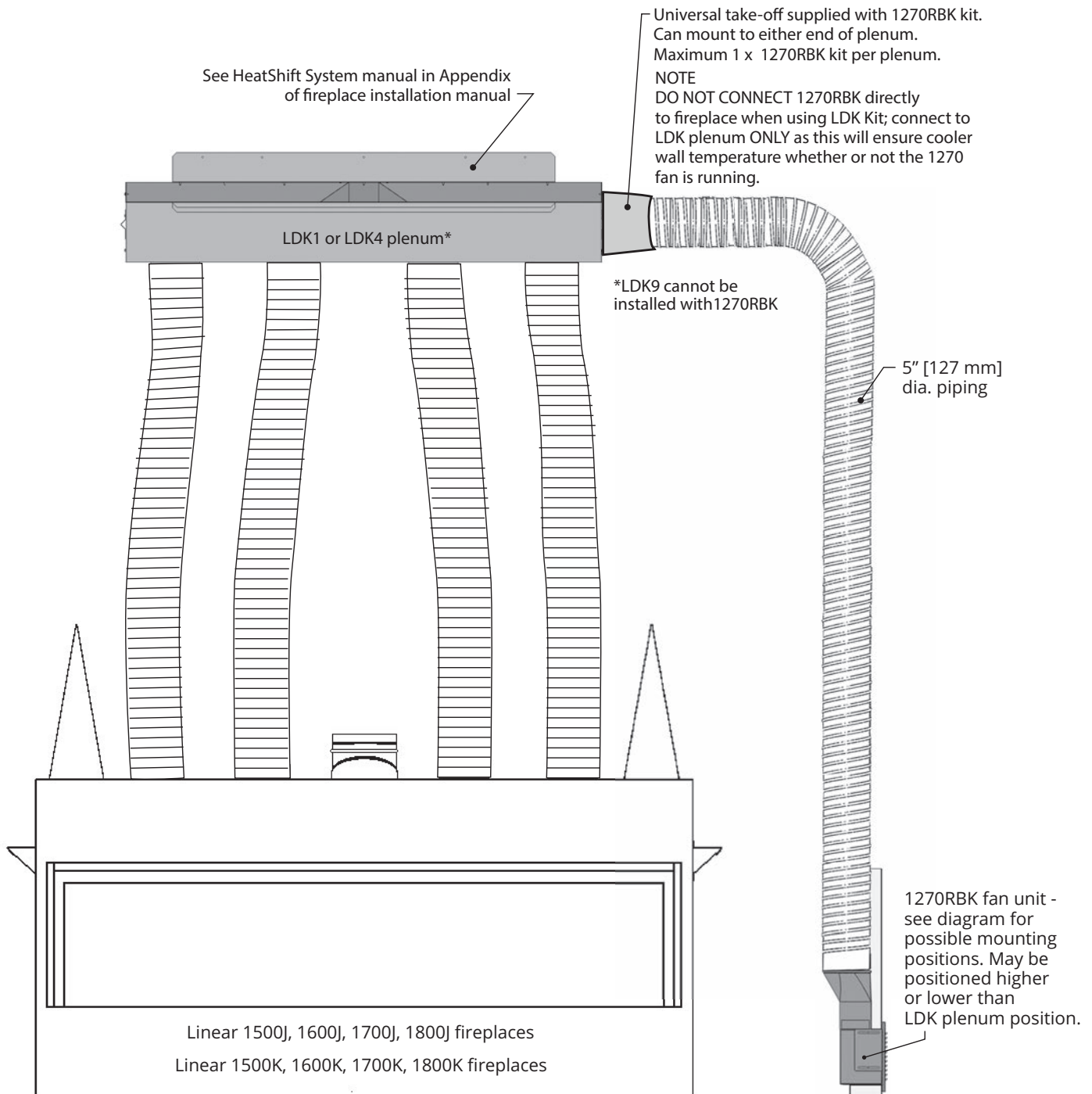

Appendix D—HeatShift System

COMBUSTIBLE Mantel Clearances Linear appliances (when using HeatShift System ONLY)

Sidewall clearances remain as stated in this installation manual.

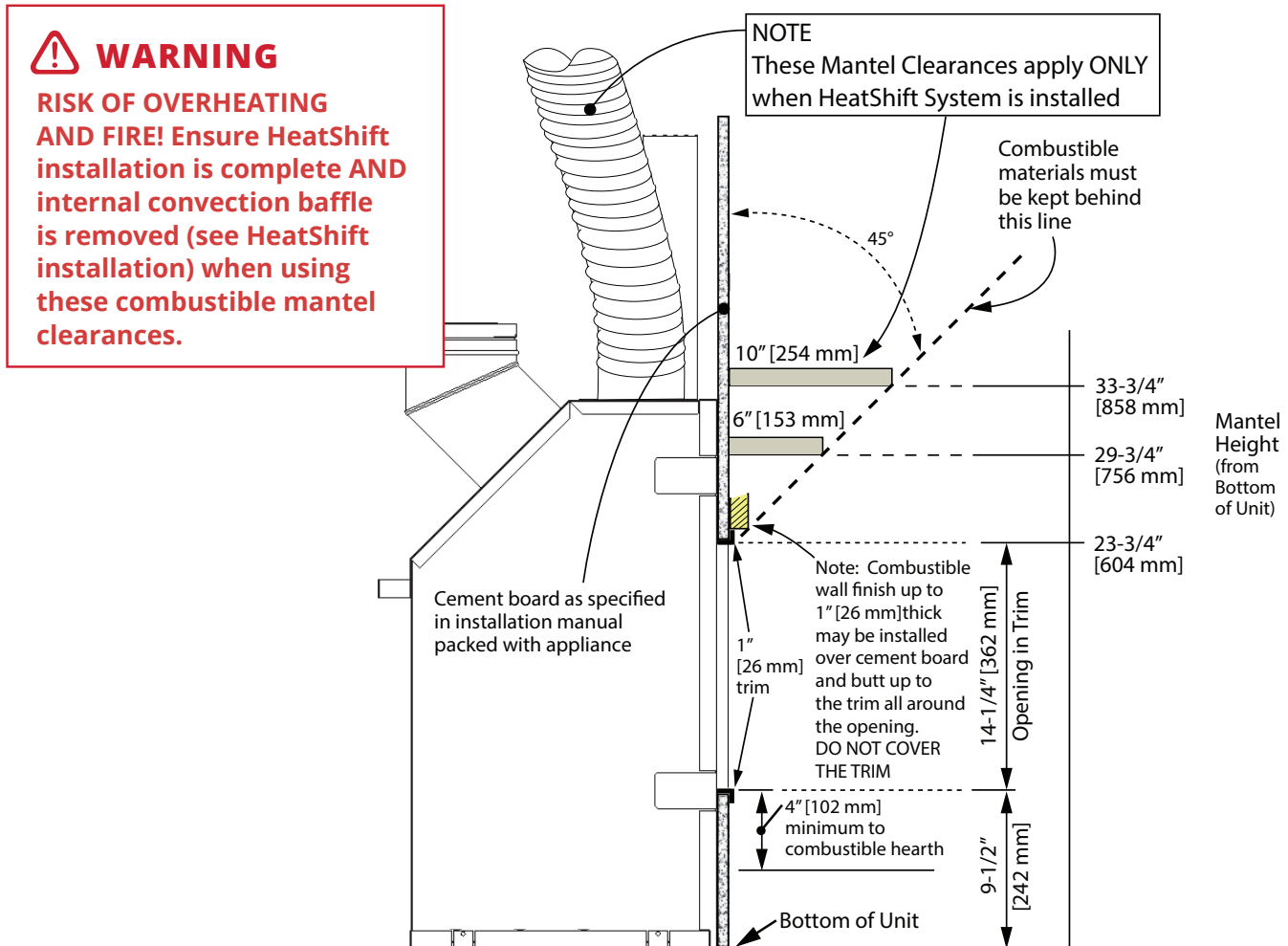

NON-COMBUSTIBLE Flush Hearth/Mantel Projections (when using HeatShift System ONLY)

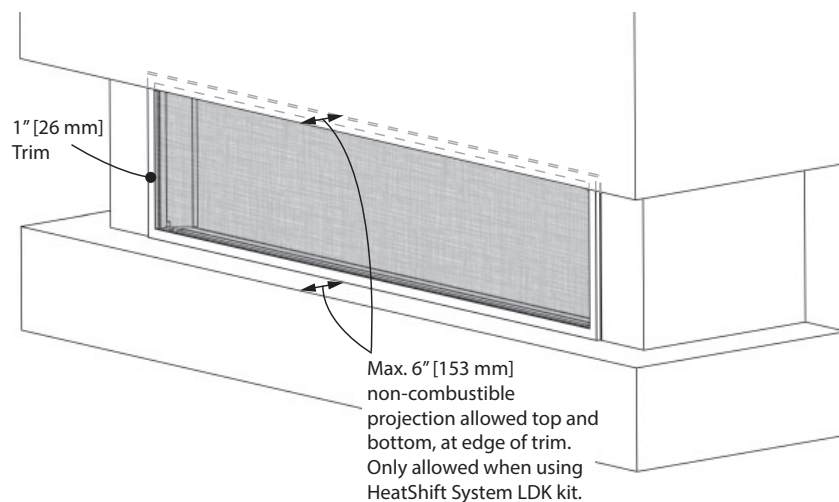

Appendix D—HeatShift System

Remove Convection Baffle

To be effective the LDK Duct Kit requires that a convection baffle located above the firebox inside the appliance case be removed to allow the hot airflow to convect upwards into ducts installed on the fireplace.

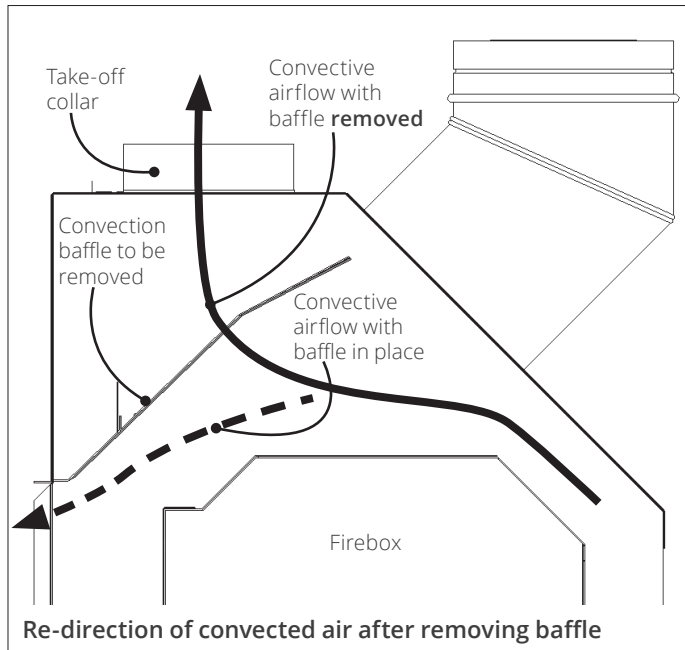

! Remove the convection baffle from the appliance. It is held in place by screws located right behind the upper edge of the fireplace opening (3 screws/baffle). Recycle this panel as it is no longer needed.

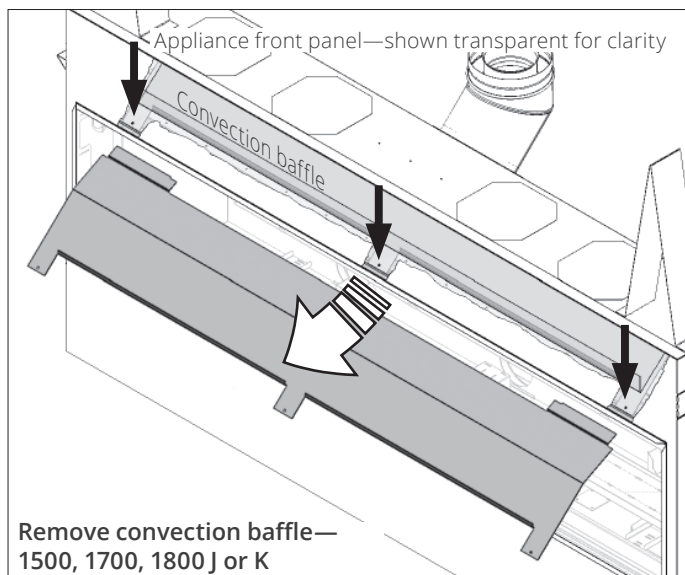

Appendix D—HeatShift System

Install HeatShift collars

1. Remove the four cover plates on top of the appliance case (6 screws each).

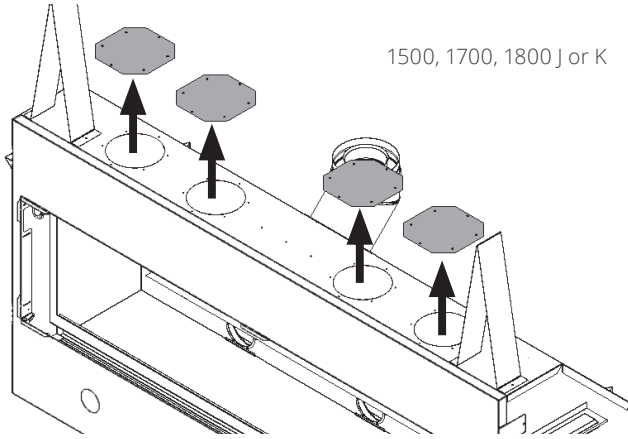

2. Install the collars on the holes on top of the appliance's case (6 screws each).

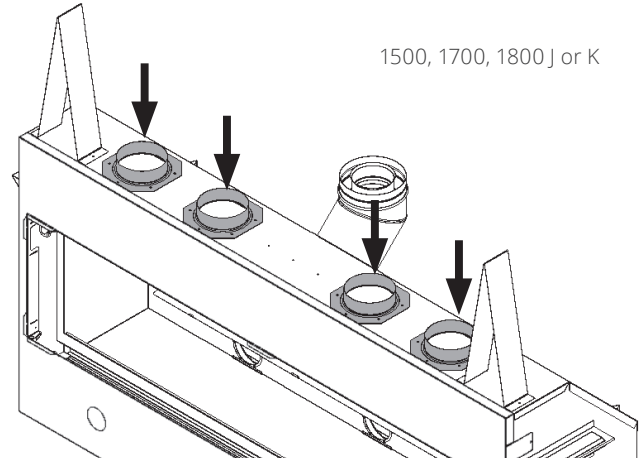

WARNING

All FOUR (4) takeoffs MUST BE CONNECTED TO PLENUM(S).

WARNING

DO NOT INSTALL 1270RBK Remote Blower Kit to any of these 4 takeoffs.

Appendix D—HeatShift System

Install Plenum Kits (LDK1, LDK3, LDK4 & LDK9) —see next page for LDK7 Duct Termination Plates

1. Frame a rough opening at the desired location—see earlier sections of this manual for allowable plenum positions and rough frame opening sizes.
2. Install top mounting bracket(s) to the plenum using screws provided (use the short sheet metal screws provided otherwise the screw tails (ends) will interfere with the finishing frame when installed).

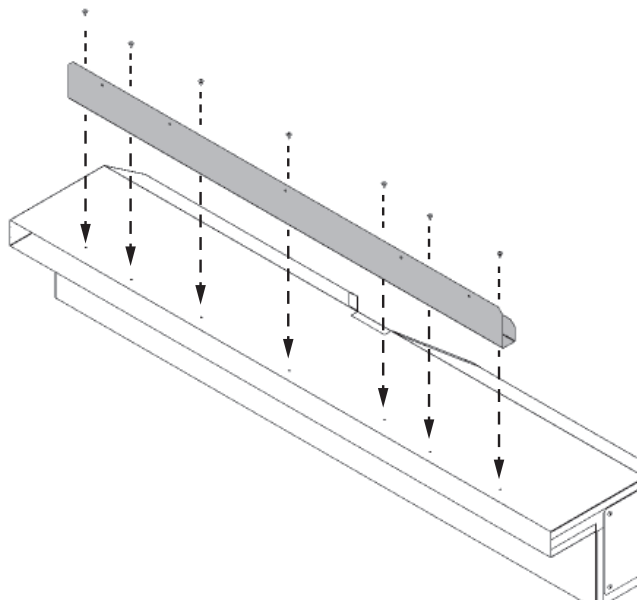

3. Install the plenum(s) into the rough frame opening maintaining minimum clearances to combustibles as listed—see Rough Frame Openings. Fix the plenum to the framing using nails or screws through the top mounting bracket. **Note that the mounting brackets are not intended to carry the weight of the plenum and pipes. Provide support to the underside of the plenum and ensure the plenum is level and its outlet is not distorted—see Framing and Clearances.** Use metal strapping (all-round, not supplied) as required to further secure the plenum to framing.
4. Attach one section of UL-181, Class 1 approved air duct to each of the collars and secure it with gear clamps provided. **DO NOT SPLICE DUCTS!**
5. Attach the top of the pipe sections to the plenum securing them with the gear clamps provided. An upward slope must be maintained in horizontal sections of pipes for proper convection. Use straps as necessary to maintain the pipes positions. Support horizontal sections every 24 inches [610 mm].

6. Paint the inside surfaces of the plenum using high-temperature flat black spray paint for installations where the inside of the plenums may be visible. **Note:** The flanges of the white finishing frame (when used) will insert approximately 1-1/4" [32 mm] into the plenum covering the shiny sheet metal.

Install the finishing frame or louver to the plenum after the wall finish is completed:

LDK1, LDK4, LDK9: Use the LDK2, LDK5 or LDK10 depending of the length of the plenum.

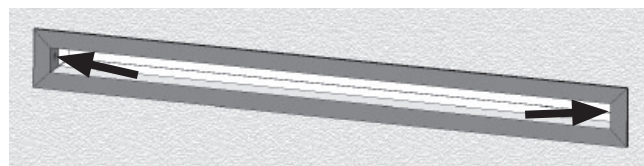

LDK3: Use the grilles provided with the kit.

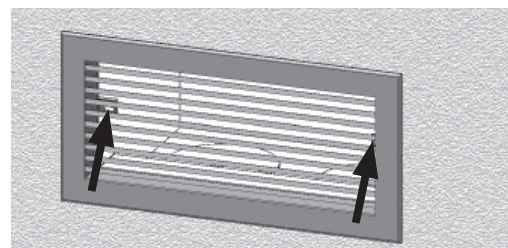

Note: The frame/louvers are finished white but may be painted another color if desired; use high temperature paint (250°F/ 121°C). You may also finish up to the perimeter of the plenum opening with your material of choice and not use the frame or louver. Do not finish over any of the opening in the plenum outlet.

7. Continue with the fireplace installation.

Appendix D—HeatShift System

Install Duct Termination Plates (LKD7)

—see previous page for LDK1, LDK3, LDK4 & LDK9 Plenum kits

1. Frame a rough opening and platform at the desired location—see earlier sections of this manual for allowable duct termination plates positions and rough frame opening sizes.
2. On each duct termination plate, rotate both stand-offs to the vertical position and secure in place using screws provided.

2 stand-offs per plate

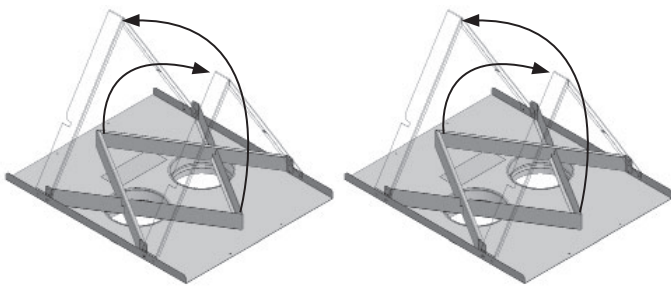

3. Install the termination plates into the framing ensuring collars/pipes on underside of plates maintain 1 inch [26 mm] clearance to combustibles and clearance to combustible above the plates are maintained as listed in Wall Valence Discharge Opening. The termination plates perimeter may be trimmed as necessary to accommodate framing. Secure the termination plate to framing using screws or nails to avoid movement.
4. Attach one section of UL-181, Class 1 approved air duct to each of the collars and secure it with gear clamps provided. **DO NOT SPLICE DUCTS!**
5. Attach the top of the pipe sections to the duct termination plates securing them with the gear clamps provided. An upward slope must be maintained in horizontal sections of pipes for proper convection. Use straps as necessary to maintain the pipes positions. Support horizontal sections every 24 inches [610 mm].
6. Continue with the fireplace installation.

Repair Parts List

	Description	Part no.
LDK1	48" Quad Hot Air Plenum Kit [1220 mm]	
	48" x 2" quad plenum [1220 x 51 mm]	4005476
	5" take-off collars (4) [127 mm]	4005478
	Top mounting bracket/standoffs	4007211
	#8 slotted drive screws 1/4" (7) [6 mm]	798601
LDK2	48" Outlet Frame Kit for LDK1 [1220 mm]	
	Aux Frame-SPL 48" x 2" white [1220 x 51 mm]	4005612
LDK3	14" Double Hot Air Plenums Kit [356 mm]	
	14" x 6" double plenums (2) [356 x 153 mm]	4005464
	5" take-off collars (4) [127 mm]	4005478
	DABL-00-C-SPL 14" x 6" Grilles white (2) [356 x 153 mm]	4005614
	Top mounting bracket/standoffs (2)	4005566
	#8 slotted drive screws 1/4" (6) [6 mm]	798601
LDK4	38" Quad Hot Air Plenum Kit [965 mm]	
	38" x 2" quad plenum [965 x 51 mm]	4005477
	5" take-off collars (4) [127 mm]	4005478
	Top mounting bracket/standoffs	4007213
	#8 slotted drive screws 1/4" (7) [6 mm]	798601
LDK5	38" Outlet Frame Kit for LDK4 [965 mm]	
	Aux Frame-SPL 38" x 2" white [965 x 51 mm]	4005613
LDK6	5" Aluminum 2-ply Flex Kit [127 mm]	
	5" dia 10' (uncompressed) aluminum chimney liners (2) [127 mm x 3 m]	4005635
	4.5" - 6.5" ss gear clamps (8) [114 - 165 mm]	4005642
LDK7	Duct Termination Plates	
	Plate and collar assembly (2)	4006747
	5" take-off collars (4) [127 mm]	4005478
	Screws 8 x 3/8 tap PN HD PH (12)	100A757
LDK9	30" Quad Hot Air Plenum Kit [762 mm]	
	30" x 2" quad plenum [762 x 51 mm]	4007903
	5" take-off collars (4) [127 mm]	4005478
	Top mounting bracket/standoff	4007601
	#8 slotted drive screws 1/4" (5) [6 mm]	798601
LDK10	30" Outlet Frame Kit for LDK9 [762 mm]	
	Aux Frame-SPL 30" x 2" white [762 x 51 mm]	4007951

Each LDK kit is sold separately.

Appendix E—Spare Parts

	Description	Part No.
1	Heat shield	4003049
2	45 degrees flanged elbow	0945M
3	Elbow gasket	4002999
4	Top stand-offs (2)	4005408
5	Restrictor plate	4003017
6	Cover plates (4)	4005409
7	Take-off cover (2)	4003046
8	Liner panels anchors (2)	4001283
9	LH Window latch assembly	4002770
10	RH Window latch assembly	4002766
11	Convection baffle	4005400
12	Cable hole cover	4003038
13	Top panel support	4002963
14	Bracket - stiffener	4007949
15	Bracket - support	4007950
16	Window assembly	4003567X
17	Hot glass warning plate	4003093
18	Black metal platform	4004138AH
19	Burner rail assembly	4006900AH
20	Platform support	4002908
21	Burner end location bracket	4002903
22	Burner module assembly (natural gas)	4006922
	Burner module assembly (propane gas)	4007736
23	Pilot shield	4003018AH
24	Pilot assembly (natural gas)	4006738
	Pilot assembly (propane gas)	4006739
24a	Plug pilot	4000726
24b	Pilot assy injector #51 (natural gas)	4000727
	Pilot assy injector #30 (propane gas)	4000728
25	Thermocouple	4000061
26	Pilot injector #51 (natural gas)	4000735
	Pilot injector #30 (propane gas)	4000736
27	Pilot tube	4000732
28	Pilot hood 2-flame	4000730
29	Extended nut	4001855
30	Electrode	4001856
31	Pilot gaskets (2)	4000715
32	Pilot stand	4006907
33	Platform support	4002908
35	Burner mounting bracket C	4007223
36	L2 Air shutter stopper	4008005
37	Injector/Burner mount	4007702
38	Gas orifice DMS #32 (natural gas)	4007000-32
	Gas orifice DMS#49 (propane gas)	4007000-49

	Description	Part No.
39	Air shutter	4007748
40	Burner module plate	4006916
41	Gaskets module plate, short (2)	3000399
42	Gaskets module plate, long (2)	3000400
43	Air shutter lever	4007225
44	#10 * 1/2 Flat washers (2)	4006692
45	3/16" * 9/16" Spring washers (2)	4006691
46	#10-24 Zinc finish steel reverse nuts (2)	4007890
47	Gas supply pipe assembly	4006923
48	Valve mount	4002905
49	GV60 valve assembly (natural gas)	4003986X
	GV60 valve assembly (propane gas)	4003987X
50	Thermocouple interrupter	4001037
51	Pipe s/s flex	4000345
52	Receiver Valor 10 Two Way	4005597
53	Wire harness GV60	4001187
54	Yellow cable to interrupter	4002096
55	Red cable to interrupter	4001035
56	Ignition cable sleeve	4002244
57	Ignition cable 500 mm	4001039
58	Valor 10 handset wall holder	4004459
59	Valor 10 button handset black	4007548
60	Remote battery & Wall switch kit	RBWSK
60a	Junction box	4005527
60b	Cover plate & 4 screws	4005526
60c	Battery holder	4006553
60d	Cable tie	4005524
60e	Harness assembly	4005523
60f	Plate with magnets	4005391
60g	Long screws (2)	4001444
60h	Wall switch with 2 screws	4005522
60i	Battery cover assembly	4005390
62	Liner panels - complete set	
	Fluted Black Liners	1715FBL
	Reflective Glass Liners	1725RGL
	Plain Black Liners	1760PBL
63	Rear panel	
	Fluted Black - centre panel only	4003955
	Glass (3)	4004275
	Plain Black - center panel only	4008535
63a	Rear panel	
	Fluted Black - sides (2)	4003727
	Glass	-
	Plain Black - sides (2)	4008534

Appendix E—Spare Parts

	Description	Part No.
64	LH side panel	
	Fluted Black	4003071
	Glass	4004273
	Plain Black	4003071
65	RH side panel	
	Black	4003072
	Glass	4004274
	Plain Black	4003072
66	Top panel	
	Black (2)	4003728
	Black (2)	4003728
	Black (2)	4003728
67	Murano Glass Fire	1700DGM
68a	Glass panel 401 x 66 mm	4003746A
68b	Glass panel 401 x 82 mm	4003746B
68c	Glass panel 119.5 x 46 mm	4003746C
68d	Glass panel 119.5 x 78.5 mm	4003746D
68e	Glass panel 384.5 x 66 mm (2)	4003746E
68f	Glass panel 384.5 x 82 mm (2)	4003746F
69	Classic 1/2" clear fireglass	4004521
70	Driftwook Kit	1705DWKV2
	Log L17	4007987
	Log L21	4007991
	Log L22	4007992
	Log L35	4008739
	Log L40	4002965
	Log L41	4009391
	Log L42	4009392
71	Brown beach pebble	4003082
72	Grey beach pebble	4003083
73	Small grey beach pebble	4003086
74	White beach pebble	4003084
75	Black beach pebble	4003085
76	Small beige beach pebble	4003087
77	Grade 1A vermiculite, bagged	4002940

	Description	Part No.
84	Rocks & Shale Set	1714RSS
85	LH twig	4001827
86	LH twig - short (2)	4001827S
87	RH twig (2)	4001828
88	Grey Rock S4-A (7)	4002338
89	Dark Grey Rock S4-A (5)	4002339
90	Grey Rock S4-B (5)	4002340
91	Dark Grey Rock S4-B (8)	4002341
92	No 7 Grey 5 Matte pitted rock	4002650
93	No 9 Grey 5 Matte rock (2)	4002652
94	No 11 Grey 3 Matte rock (2)	4002654
95	No 14 Grey 9 Gloss rock	4002657
96	No 16 Warm Grey 3 Gloss pitted rock (2)	4002659
97	No 17 Grey 5 Gloss pitted rock	4002660
98	Shale 3/4" - grey, black 0.5lb ea	4004792
99	Splitwood Kit	1705SWKV2
100	Splitwood Logs only	4009519
	Splitwood log #20	4008743
	Splitwood log #21	4008744
	Splitwood log #28	4008751
	Splitwood log #31	4009393
	Splitwood log #32	4009394
	Splitwood log #33	4009395
	Splitwood log #36	4009444
	Splitwood log #37	4009445
	Splitwood log #38	4009446
101	Mixed grey embers, 8-cup bag	4008046
102	Birch Logs Kit	1705BLKV2
	Birch log #L2	4007372
	Birch Log #L4	4007374
	Birch Log #L6	4007376
	Birch Log #L10	4007380
	Birch Log #L12	4007382
	Birch Log #L30	4008758
	Birch Log #L31	4008759
	Birch Log #L32	4008760
	Birch Log #L13	4009422
103	Ceramic log supports (2)	4007649
104	Mixed grey embers, 8-cup bag	4008046
105	GV60 Valve Repair Kit	4004544

Appendix E—Spare Parts

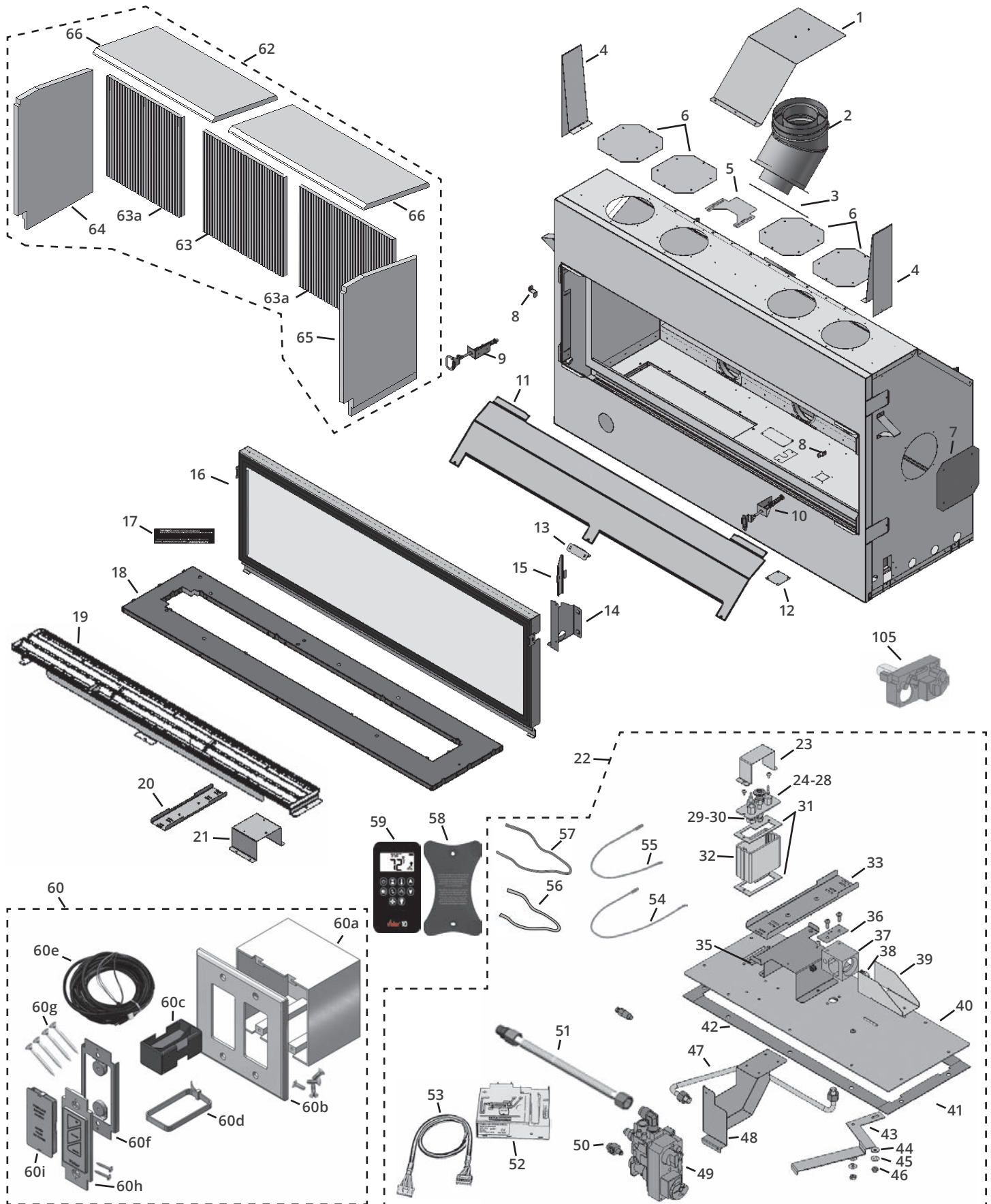

Appendix E—Spare Parts

