

# valor<sup>®</sup> Horizon



## Direct Vent Gas Fireplace 534JN (natural gas) & 534JP (propane gas)

### **DANGER**



**HOT GLASS WILL CAUSE BURNS.**

**DO NOT TOUCH GLASS UNTIL COOLED.**

**NEVER ALLOW CHILDREN TO TOUCH GLASS.**

A barrier designed to reduce the risk of burns from the hot viewing glass is provided with this appliance and must be installed for the protection of children and other at-risk individuals.

**Please read this manual BEFORE installing and operating this appliance.**

**INSTALLER:** Leave this manual with the appliance.  
**CONSUMER:** Retain this manual for future reference.

This manual contains instructions to install the **ENGINE ONLY**. A front kit is **REQUIRED** to complete the installation. A barrier screen is provided with the front kit. **Refer to the manual supplied with the front for installation.**

**⚠ WARNING**  
**FIRE OR EXPLOSION HAZARD**  
Failure to follow safety warnings exactly could result in serious injury, death, or property damage.

- Do not store or use gasoline or other flammable vapors and liquids in the vicinity of this or any other appliance.
- **WHAT TO DO IF YOU SMELL GAS**
  - Do not try to light any appliance.
  - Do not touch any electrical switch; do not use any phone in your building.
  - Leave the building immediately.
  - Immediately call your gas supplier from a neighbor's phone. Follow the gas supplier's instructions.
  - If you cannot reach your gas supplier, call the fire department.
- Installation and service must be performed by a qualified installer, service agency or the gas supplier.

This appliance may be installed in an after-market permanently located, manufactured (mobile) home where not prohibited by local codes.

This appliance is only for use with the type of gas indicated on the rating plate. This appliance is not convertible for use with other gases, unless a certified kit is used.

This appliance is a domestic room-heating appliance. It must not be used for any other purposes such as drying clothes, etc.

This appliance is suitable for installation in a bedroom or bed sitting room.

Installer: Place model/serial number here.

Ce guide est disponible en français sur demande.

# Table of Contents

## FOR THE OWNER

<b>Safety and Your Fireplace</b> .....	<b>3</b>
<b>Introduction</b> .....	<b>6</b>
Locating Fireplace & Lighting Information Card .....	6
Operating Your Fireplace for the First Time.....	6
<b>Operating Your Fireplace</b> .....	<b>7</b>
Fireplace Control Devices .....	7
How to Turn Your Fireplace OFF (including pilot).....	7
How to Ensure Your Fireplace Cannot Be Turned ON Inadvertently .....	7
<b>Using the Remote Control</b> .....	<b>8</b>
<b>Kits &amp; Accessories</b> .....	<b>12</b>
<b>Lighting Instructions</b> .....	<b>13</b>
<b>Servicing &amp; Maintenance</b> .....	<b>14</b>
Servicing Your Fireplace.....	14
Annual Inspection .....	14
Cleaning Your Fireplace .....	15
Checking Pilot and Burner Flames .....	17
Replacing Batteries .....	18
Using Handset Wall Holder.....	18
<b>Warranty</b> .....	<b>52</b>

## FOR THE QUALIFIED INSTALLER

<b>Specifications</b> .....	<b>19</b>
<b>Overview</b> .....	<b>20</b>
<b>Dimensions</b> .....	<b>21</b>
<b>Framing</b> .....	<b>22</b>
<b>Location</b> .....	<b>23</b>
<b>Venting</b> .....	<b>23</b>
<b>Co-Axial Venting</b> .....	<b>24</b>
<b>Co-Linear Venting</b> .....	<b>30</b>
<b>Installation</b> .....	<b>31</b>
Remove Window .....	31
Convert to Rear Vent Outlet (if required) .....	31
Install 817VAK Vent Adapter.....	31
Install Top Heat Shield & Stand-offs .....	32
Install Support Angles.....	32
Remove Rear Log Support.....	32
Install Air Restrictors.....	33
Re-install Rear Log Support .....	34
Install Appliance Into Framing .....	34
Connect Gas Supply.....	35
Install Liner Panels .....	36
Install 534LSK Traditional Logs .....	37
Install 534RSK Ceramic Rocks .....	39
Install 534DWK Driftwood Kit .....	41
Refit and Check Window .....	43
Install Battery Holder .....	44
Synchronize Remote Control.....	44
Check Operation.....	45
Adjust Aeration (if needed) .....	45
Install Front, Trim and Barrier Screen.....	46
Install Handset Wall Holder .....	46
<b>Wiring Diagram</b> .....	<b>47</b>
<b>Approved Venting Components</b> .....	<b>48</b>
<b>Commonwealth of Massachusetts</b> .....	<b>50</b>
<b>Warranty</b> .....	<b>52</b>
<b>Replacement Parts</b> .....	<b>53</b>

**Warranty Card at the back of this manual.**

**NATIONAL  
FIREPLACE  
INSTITUTE**



**CERTIFIED**  
www.nficertified.org

We recommend that our gas hearth products be installed and serviced by professionals who are certified in the U.S. by the National Fireplace Institute® (NFI) as NFI Gas Specialists.

The information contained in this installation manual is believed to be correct at the time of printing. Miles Industries Ltd. reserves the right to change or modify any information or specifications without notice. Miles Industries Ltd. grants no warranty, implied or stated, for the installation or maintenance of your heater, and assumes no responsibility for any consequential damage(s).

**Massachusetts: The piping and final gas connection must be performed by a licensed plumber or gas fitter in the State of Massachusetts. Also, see Carbon Monoxide Detector requirements on page 50.**

**Designed and Manufactured by / for  
Miles Industries Ltd.**

**190–2255 Dollarton Highway, North Vancouver, BC, CANADA V7H 3B1**

**Tel. 604-984-3496 Fax 604-984-0246**

**www.valorfireplaces.com**



## SAFETY AND YOUR FIREPLACE

**Read and understand** all instructions carefully before starting the installation. **Failure to follow** these installation instructions may result in possible fire hazard and will void the warranty.

**Prior to the first firing of the fireplace**, read the Owner's information section of this manual.

**Do not use this appliance if any part has been under water.** Immediately, call a qualified service technician to inspect the unit and to replace any part of the control system and any gas control that has been under water.

**This unit is not for use with solid fuel.**

**Installation and repair should be performed by a qualified service person.** The appliance and venting system should be **inspected** before initial use and at least annually by a professional service person. More frequent cleaning may be required due to excessive lint from carpeting, bedding, etc. It is **imperative** that the unit's control compartment, burner, and circulating air passageways **be kept clean** to provide for adequate combustion and ventilation air.

**Always keep the appliance clear and free from combustible materials**, gasoline, and other flammable vapors and liquids.

**Never obstruct the flow of combustion and ventilation air.** Keep the front of the appliance **clear** of all obstacles and materials for servicing and proper operation.

**This unit must be used with a vent system** as described in this installation manual. **No other** vent system or components **may be used**.

This gas fireplace and vent assembly must be vented directly to the outside and must never be attached to a chimney serving a separate solid fuel burning appliance. Each gas appliance must use a separate vent system. Common vent systems are prohibited.

**Inspect the external vent cap** on a regular basis to make sure that no debris, plants, trees, shrubs are interfering with the air flow.

**Turn off the gas before servicing** this appliance. It is recommended that a qualified service technician perform an appliance check-up at the beginning of each heating season.



### WARNING:

This product can potentially expose you to chemicals including Benzene which are known to the State of California to cause cancer and birth defects or other reproductive harm. **For more information go to [www.P65Warnings.ca.gov](http://www.P65Warnings.ca.gov)**

**Do not use this heater as a temporary source of heat during construction.**

Due to the high temperature, the appliance should be **located** out of traffic areas and away from furniture and draperies.

Clothing or flammable material **should not be placed** on or near the appliance.

This appliance is a **domestic room-heating appliance**. It must not be used for any other purposes such as drying clothes, etc.

**Do not** place furniture or any other combustible household objects within 36" of the fireplace front.

**Be careful not to put any decorating objects** sensitive to heat to close above or around the fireplace as it gets very hot when operating.

**The glass door assembly must be in place and sealed before the unit can be placed into safe operation.**

**Do not operate this appliance with the glass door removed, cracked, or broken.** Replacement of the glass door should be performed by a licensed or qualified service person. Do not strike or slam the glass door.

**The glass door assembly shall only be replaced as a complete unit**, as supplied by the fireplace manufacturer. No substitute material may be used.

Do not use abrasive cleaners on the glass door assembly. Do not attempt to clean the glass door when it is hot.

**A barrier designed to reduce the risk of burns** from the hot viewing glass is provided with this appliance and **shall be installed for the protection of children and other at-risk individuals.**

If the barrier becomes damaged, the barrier shall be replaced with the manufacturer's barrier for this appliance.

Any safety screen, guard or barrier removed for servicing the appliance, must be replaced prior to operating the appliance.

**Children and adults** should be alerted to the hazards of high surface temperature and should stay away to avoid burns or clothing ignition.

**Young children** should be carefully supervised when they are in the same room as the appliance. Toddlers, young children and others may be susceptible to accidental contact burns. A physical barrier is recommended if there are at-risk individuals in the house. To restrict access to a fireplace or stove, install an adjustable safety gate to keep toddlers, young children and other at-risk individuals out of the room and away from hot surfaces.



# Safety and Your Fireplace

## Read and carefully follow all safety warnings and operating instructions contained in your owner's manual

Replacement manuals are available by contacting the Valor Service Department at 1-800-468-2567 or visit [www.valorfireplaces.com](http://www.valorfireplaces.com).

### FOLLOW THESE IMPORTANT CHILD SAFETY PRECAUTIONS AND RECOMMENDATIONS

**Parts of your Valor Fireplace become extremely hot while in operation.**

**The glass viewing window temperature can exceed 500 F** at full capacity.

**Momentary contact with a hot glass surface can cause a severe burn**, even if the fireplace is operating at reduced heating capacity.

**The glass window will remain hot** for an extended period of time after the fireplace has been turned off. Ensure that children are prevented from touching the fireplace during the cool down period.

**Toddlers and Young Children must be closely supervised at all times** when they are in the same room as the operating fireplace. They lack full awareness of danger and rely on your protection. Toddlers, in particular, do not have the motor skills and response reflexes to withdraw in the event of accidental contact with a hot surface.

**A physical barrier is strongly recommended** if there are young children, or at-risk individuals in the house. Install an approved after-market safety gate to keep toddlers, young children and



other at-risk individuals a safe distance from the fireplace.

**Keep the remote control handset out of reach of children at all times.** A wall mount storage holster is provided with your remote control handset.

**Ensure that the fireplace, including the pilot light, is completely turned off** when children are present and close supervision and safety barriers are not available—see page 7 of this manual.

**If the fireplace is not going to be used** for the summer or any extended period of time, remove the batteries from the remote control handset and remote battery holder. It is recommended that batteries are replaced annually in any event—see page 18.



## SAFETY AND YOUR FIREPLACE

This manual and particularly the preceding and following pages contain very important information regarding the safe operation of your fireplace as well as maintenance instructions. Read carefully before operating your fireplace and pay special attention to the safety warnings.

A heating gas appliance does require safe handling. For this reason, we very strongly recommend children are not allowed to touch the fireplace or controls. **Install a screen or barrier in front of the fireplace to protect your children against severe burns.**

This appliance is designed and approved as a supplemental heater and provides the potential for most energy conservation when used while attended. The use of an alternate primary heat source is advisable.



## WARNING EXTREMELY HOT!!!

- **Read the safety information on pages page 3 and page 4 of this manual before operating your gas heater.**
- Some parts of your fireplace are **extremely hot**, particularly the **glass** window.
- **Do not let children touch the glass** or any parts of your fireplace **even after it is turned off** as it is still hot.
- **Use the barrier screen** provided with the trim or a gate to reduce the risk of severe burns.
- Keep the remote control handset **out of reach of children.**
- **Hot hearth/floor surface!** The hearth or floor directly in front of the fireplace is **very hot** when the fireplace heats. Even if constructed of non-combustible materials, and although safe, it may reach temperatures **in excess of 200° F** depending on choice of materials. **Do not step on it!**
- Some materials or items, although safe, may discolor, shrink, warp, crack, peel, and so on because of the heat produced by the fireplace. **Avoid placing** candles, paintings, photos, and other items **sensitive to heat** within 36 inches (0.9 m) around the fireplace.
- Solid wood flooring in front of the fireplace (if allowed) may shrink during the heating season due to heat.

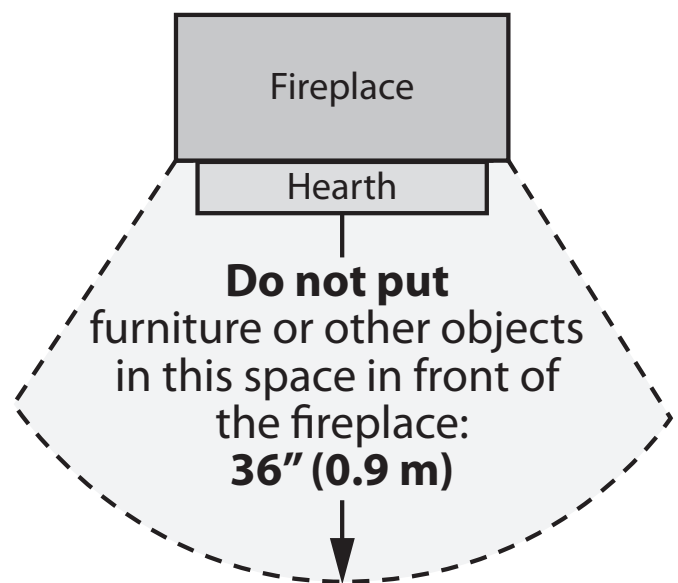



**Thank You ...**

For purchasing a Valor by Miles Industries. Your new radiant gas heater is a technical appliance that must be installed by a qualified dealer. Each Valor fireplace is fully tested during the production process for your safety and comfort.

Your unit has been professionally installed by:

Dealer Name: \_\_\_\_\_

Phone Number : \_\_\_\_\_

**Should you encounter an operational problem, call your dealer immediately.**

**Do not try to repair the unit as you may cause an injury or damage the fireplace.**

**Locating Fireplace & Lighting Information Card**

**⚠ WARNING**

**DO NOT ATTEMPT TO TOUCH THE DATA CARD WHILE THE FIREPLACE IS STILL HOT!** Let the fireplace cool first before touching it.

The Fireplace and Lighting Information card is located under the firebox.

To access the plate, remove any fret or access panel and grab the plate and slide it out to read it. There is important information on both sides of the plate.

**Fireplace model**

**Serial number**

The diagram shows a data card with the following fields:

- MODEL/MODELE: 739MN
- FOR NATURAL GAS / POUR LE GAZ NATUREL
- Serial Number: 739N 10000
- Max BTU/h: 24,000
- Min BTU/h: 6,500
- Height: 3.2"
- Depth: 5.0"
- Valve: 750

**Operating Your Fireplace for the First Time**

When operating your new fireplace for the first time, some vapors may be released due to the burning of curing compounds used in the manufacture of the appliance. They may cause a slight odor and could cause the flames to be the full height of the firebox, or even slightly higher, for the first few hours of operation.

It is also possible that these vapors could set off any smoke detection alarms in the immediate vicinity.

These vapors are quite normal on new appliances. We recommend opening a window to vent the room. After a few hours use, the vapors will have disappeared and the flames will be at their normal height.

**Flame Supervision Device**

For your safety, this appliance is fitted with a flame supervision device which will shut-off the gas supply if, for any reason, the pilot flame goes out. This device incorporates a fixed probe, which senses the heat from the pilot flame. If the probe is cool, the device will prevent any gas flow unless manually lighting the pilot. See full lighting instructions on page 13 of this manual.

**Performance of propane gas appliances may be affected by the quality of commercial gas supplied in your area.**

# Operating Your Fireplace

## Fireplace Control Devices

There are three ways to control your fireplace.

1. Thermostatic Remote Control;
2. Manual On/Off Switch;
3. Wall Switch (optional) .

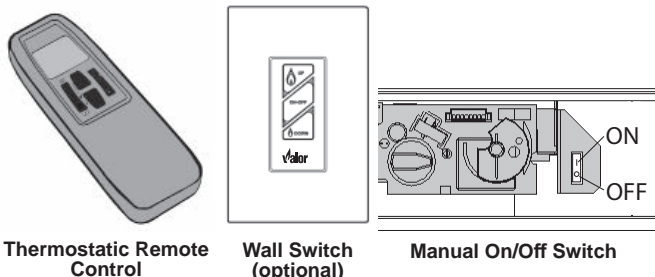

The Thermostatic Remote Control can be programmed to function automatically—see page 8.

The manual On/Off switch must be ON for the fireplace to function. It can be used to shut off the fireplace in case of emergency—see below.

The Wall Switch (optional) can be used to turn on, off and to increase or decrease the flame height—see 1265WSK or RBWSK—Wall Switch Kit.

**NOTE:** The remote control in the AUTO mode will override the wall switch.

### How to Turn Your Fireplace OFF (including pilot)

Familiarize yourself with each of these methods before operating your fireplace.

**Handset and Wall Switch:** Press and hold the OFF button for a second (either on the handset or the wall switch).

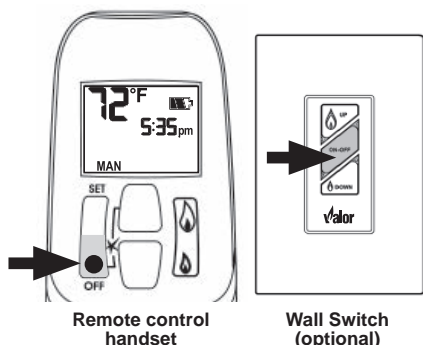

If the flames are on, they go down and you hear the valve motor wind down. You hear a clunk and a beep indicating that the valve has received the signal from the remote control.

In the unlikely event that you cannot turn off your fireplace with the remote control handset, use the wall switch (if installed); if the wall switch malfunctions and will not turn off the fireplace, wait 6 hours and the fireplace will automatically go to pilot. You can then access the controls inside your fireplace. Alternately, turn off gas supply. In all cases, call your dealer for service assistance.

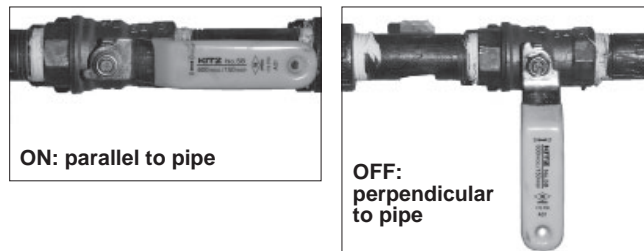

### How to Ensure Your Fireplace Cannot Be Turned ON Inadvertently

You can use one of the two following methods to ensure that your fireplace will not turn on when you don't want it on.

**⚠ WARNING**

**RISKS OF SEVERE BURNS! SURFACES OF THE FIREPLACE ARE VERY HOT DURING OPERATION!** Be very careful and wear gloves to access controls.

- You can prevent your fireplace from lighting by pressing the **O** button on the manual ON/OFF switch on the gas valve.

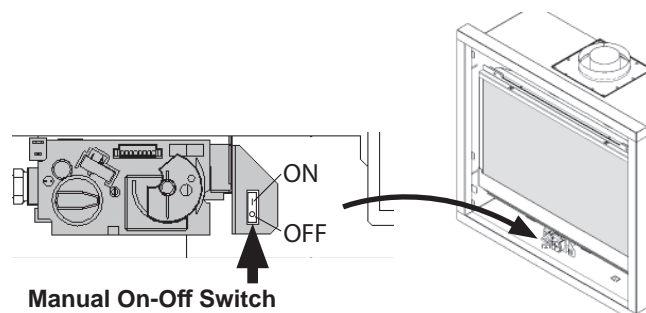

- Alternately, you can remove all batteries from the battery holder as well as the battery from the handset.

### Automatic Shut-Off (in certain conditions)

Your fireplace's remote control is equipped with an automatic shut-off mechanism which is activated in certain conditions. See page 11 in the *Using the Remote Control* section for a description of this feature.

## Using the Remote Control

### Radio Frequency

315 MHz for USA and Canada.

This device complies with Part 15 of the FCC Rules and with Industry Canada license-exempt RSS standard(s). Operation is subject to the following two conditions:

- (1) this device may not cause harmful interference, and
- (2) this device must accept any interference received, including interference that may cause undesired operation.

**NOTE: Before using the remote control system for the first time**, the receiver and the handset must be synchronized. See the section *Synchronize Remote Control* on page 1.

**IMPORTANT: BEFORE YOU BEGIN**, please note that on this system, the settings of time, temperature and automatic ON/OFF **can only be programmed when the function display is flashing**. Be patient when programming as it can take a few seconds to set.

Note: In the TEMP or TIMER modes, the remote handset senses the room temperature and adjusts the flame accordingly.

To communicate, the handset should be within 15 feet (4.5 meters) of the fireplace.

**Do not leave the handset on the mantel or hearth.**

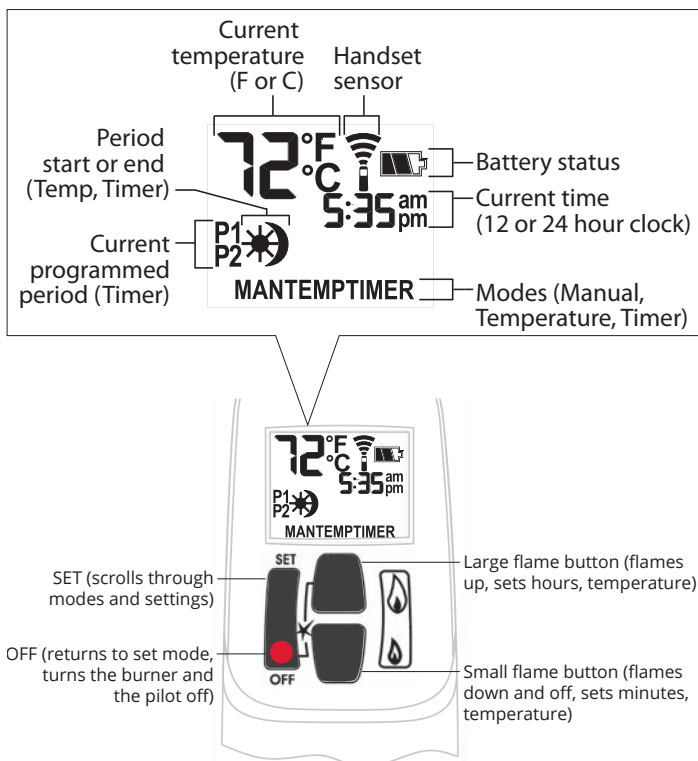

### Turn Fireplace ON

Press ● + 🔥 buttons until you hear a short beep; release buttons.

Beeping continues until pilot is lit.

Burner lights to maximum flame height and handset goes automatically to manual (MAN) mode.

NOTES:

On the valve, MAN button must be at ON, in full counter-clockwise position .

ON/OFF switch (if equipped) must be in I (ON) position.

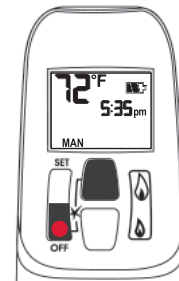

### Turn Fireplace OFF

Press ● button.

When pilot is just turned off, wait 2 minutes to light it again.

### Standby Mode (Pilot Flame)

Press and hold 🔥 to set fireplace to pilot.

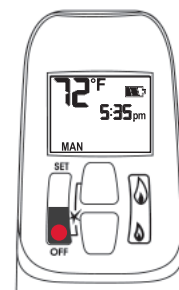

### Adjust Flames Height

With pilot lit, press and hold buttons:

- 🔥 = increase flame height
- 🔥 = decrease flame height or set to pilot

For fine adjustment, tap buttons.

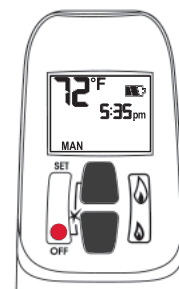

### Express Low and High Fire

Double-click buttons:

- 🔥 = increase flame to maximum height "HI"
- 🔥 = decrease flame minimum height "LO"

NOTE: Flame goes to high fire first before going to designated low fire.

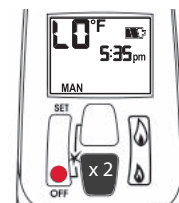
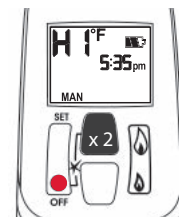



# Using the Remote Control

## Setting °C/24-hr or °F/12-hr clock

In MAN mode, press and hold ● + 🔥 buttons until temperature / clock display changes from

°F / 12-hour ↔ °C / 24-hour

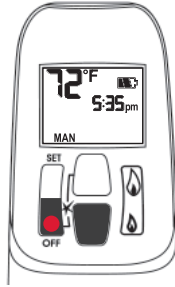

## Setting Time

The time display will flash after either:

- installing the battery, or
- pressing 🔥 + 🔥

To set the time, press buttons:

🔥 = hour

🔥 = minutes

Press ● or wait to go back to MAN.

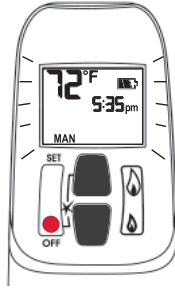

## Modes of Operation

Briefly pressing SET cycles through modes of operation.

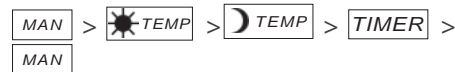

NOTE: Press 🔥 or 🔥 to reach MAN mode.

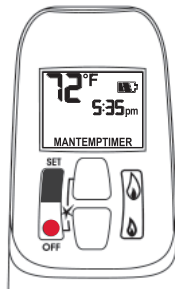

## MAN Manual Mode

Manual flame height adjustment.



## ⚡TEMP Daytime Temperature Mode

When pilot is lit, room temperature is measured and compared to set temperature. Flame height automatically adjusts to reach Daytime Set Temperature.



## 🌙TEMP Night time Setback Temperature Mode

When pilot is lit, room temperature is measured and compared to set temperature. Flame height automatically adjusts to reach Night Time Setback Temperature.

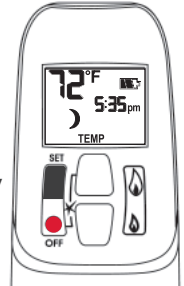

## TIMER Timer Mode

When pilot is lit, two periods of time (P1 and P2) can be programmed to use Daytime and Night time temperatures at specific times.

Note: Display shows set temperature every 30 seconds.

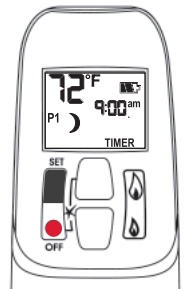

Set the different parameters when they are flashing.

## Using the Remote Control

### Setting high / low Temperatures

#### Setting "DAYTIME" high temperature.

Default Settings:  TEMP 23 °C/74 °F

Press SET to scroll to  TEMP

Hold SET button until TEMP flashes.

To set  Daytime Temperature:

 = increases temperature.

 = decreases temperature.

Press  or wait to complete setting.

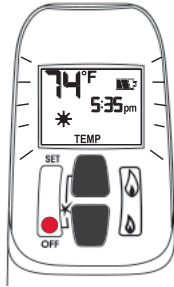

#### Setting "NIGHT TIME SETBACK" low temperature.

Default Settings:  TEMP "--" (OFF)

Press SET to scroll to  TEMP

Hold SET button until TEMP flashes.

To set  Night Time Temperature:

 = increases temperature.



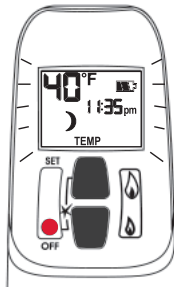

 = decreases temperature.

Press  or wait to complete setting.



### Setting Program Timers



You can program two periods of time between 12 am and 11:50 pm in each 24-hour cycle.



Programs P1 and P2 must be set in the following order during a 24-hour cycle: **P1** , **P1** , **P2**  and **P2** .

 = Day Time temperature (high) program period

 = Night Time temperature (low) program period





#### Default Settings:



Program 1: **P1**  06:00 am **P1**  08:00 am





Program 2: **P2**  11:50 pm **P2**  11:50 pm

Press SET to scroll to .



If **P1**  = **P1**  or **P2**  = **P2** , programming is cancelled.

To keep fireplace ON all night, set **P2**  at 11:50 am and **P1**  at 12:00 am.

If you want to program only one period, program **P1**  and **P1**  with desired times then **P2**  and **P2**  with the same time as **P1** .

#### Setting P1 time—high temperature.

Hold SET button until **P1**  is displayed and time flashes.

To set time:

 = hour

 = minutes

Press  or wait to complete setting.

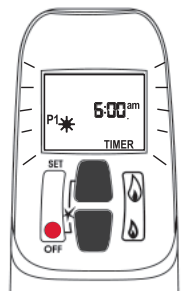

#### Setting P1 time—low temperature.

Hold SET button until **P1**  is displayed and time flashes.

To set time:

 = hour

 = minutes

Press  or wait to complete setting.

## Using the Remote Control

### Setting P2 high and low temperature times.

Repeat same steps as Setting P1.

When all settings are complete, press ● to save them.

### Timer Programming Example (default temperatures shown)

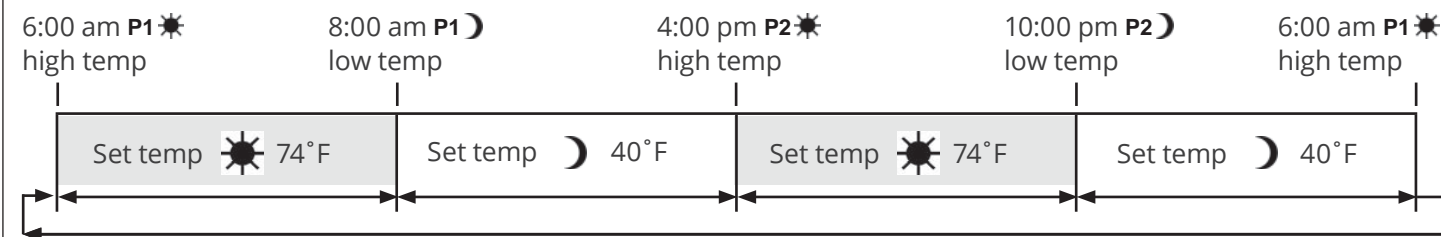

### Automatic Turn Down

#### 8 Hour no Motor Movement

The valve will turn to pilot flame if there is no motor movement for an 8-hour period.

### Automatic Shut-Off

**Low Batteries Receiver.** With low battery power in the battery holder the system shuts off the fire completely. This does not apply when the power supply is interrupted.

**On-Demand Pilot (7 Day Shut-Off).** This green feature eliminates gas energy consumption during extended appliance inactivity. When the appliance is inactive for an extended period of time the system automatically extinguishes the pilot. This feature helps the consumer realize cost benefits by automatically eliminating energy consumption during non-heating months and limited use.

The programmed length of inactivity to activate the system is specified by the appliance manufacturer and cannot be altered in the field.

### Low Battery Indication

#### Caution

**DO NOT USE** a screwdriver or other metallic object to remove batteries from holder. This could cause a short-circuit.

**Handset:** The battery icon  will show when the battery needs to be replaced. Replace with one 9 V **alkaline** battery.

**Battery holder:** Frequent 'beeps' for 3 seconds when the valve motor turns indicate the batteries need to be replaced in battery holder. Replace with four 1.5 V **alkaline** batteries.

### Handset / Receiver Match

The remote control handset and receiver are programmed to function together. In case of a replacement of the handset or the receiver, you will need to reset the receiver to allow them to function together. Contact your dealer for details.

## Kits & Accessories

### Required Kits

Information accurate at the time of printing and subject to change without notice.

<b>Fuel Beds (choose one)</b>		
534LSK	Traditional Log Set	
534RSK	Rock Set	
534DWK	Driftwood Kit	
<b>Liners (choose one)</b>		
618RGL	Reflective Glass Liners	
620FBL	Fluted Black Liners	
621VRL	Valor Red Brick Liners	
622LSL	Ledgestone Liners	
<b>Fronts (choose one)</b>		<b>Barrier Screen</b>
601	Contemporary Steel Front	4003550
602	Traditional Cast Front	4003294
610	FenderFire Double Door Front	door
645	Clearview Front	4004875
672	Matt Black Front	4004666
673	Edgemont Door Front	4005065

### Optional Accessories

Information accurate at the time of printing and subject to change without notice.

<b>Conversion Kits</b>	
534NGK	Conversion to natural gas
534PGK	Conversion to propane gas
<b>Other Accessories</b>	
GV60CKO	Outdoor Fireplace Conversion Kit
1265WSK	Wall Switch Kit
RBWSK	Remote Battery & Wall Switch Kit
755CFK	Circulating Fan Kit
<b>Hearth Gate</b>	Hearth gates such as Cardinal's VersaGates are available at retail stores carrying safety products for children.

# Lighting Instructions

## FOR YOUR SAFETY, READ BEFORE LIGHTING

**WARNING:** If you do not follow these instructions exactly, a fire or explosion may result causing property damage, personal injury or loss of life.

- A. This appliance has a pilot which must be lighted by hand or by remote control. Follow these instructions exactly. To save gas, turn the pilot off when not using the appliance for a prolonged period of time.
- B. **BEFORE LIGHTING**, smell all around the appliance area for gas. Be sure to smell next to the floor because some gas are heavier than air and will settle on the floor.

### WHAT TO DO IF YOU SMELL GAS

- Do not try to light any appliance.
  - Do not touch any electric switch; do not use any phone in your building.
  - Immediately call your gas supplier from a neighbor's phone. Follow the gas supplier's instructions.
  - If you cannot reach your gas supplier, **call the fire department.**
- C. Use only your hand to push in or turn the control knobs. Never use tools. If the knobs will not push in or turn by hand, **don't try to repair them; call a qualified service technician. Force or attempted repair may result in a fire or explosion.**
- D. Do not use this appliance if any part has been under water. **Immediately call a qualified service technician** to inspect the appliance and to replace any part of the control system and any gas control, which has been under water.

## LIGHTING INSTRUCTIONS

1. STOP! Read the safety information above. Dependent on model, switch #1 may be mounted directly to valve see Fig 2A.

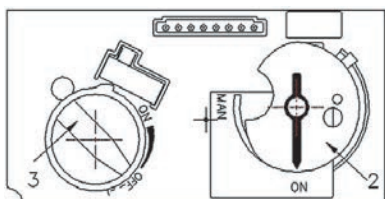

**Fig 1**

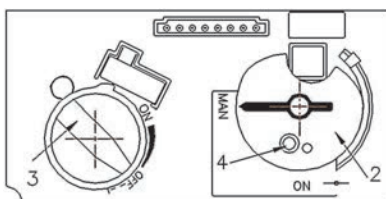

**Fig 2**

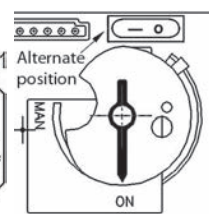



**Fig 2A**

2. SET ON/OFF SWITCH (1) TO "OFF" POSITION.

- Wait five (5) minutes to clear out any gas, then smell for gas, including near the floor. If you smell gas, STOP! Follow "B" in the safety information above on this label. If you don't smell gas, go to the next step.

3. AUTOMATIC IGNITION (fig. 1): Locate the pilot (fig. 3.) inside of firebox at Left Hand side.

- ON/OFF switch (1) in ON position, MAN-knob (2) in ON position; set Flame Adjustment knob (3) to lowest setting (∩);
- On the remote control handset, press and hold the 'off' button and  (large flame) simultaneously; a short acoustic signal confirms the start has begun;
- Further short acoustic signals indicate the ignition process is in progress;
- When the pilot is lit, the Flame Adjustment knob (3) will automatically rotate to the highest setting.
- Press the  (small flame) on the remote control handset to reduce the flame height.

4. MANUAL IGNITION (fig. 2): With the window off, locate the pilot (fig. 3) inside of firebox at Left Hand side;

- ON/OFF switch (1) in ON position, MAN-knob (2) in MAN position;
- Set Flame Adjustment knob (3) to the lowest setting (∩);
- Push down the metallic core (4) with a pen or similar instrument; this will establish the pilot gas flow;
- **Light gas at the pilot (5) with a match;**
- Continue holding down metal core (4) for about 10 seconds; after release, pilot should remain lit;
- If the pilot will not stay lit after several tries, turn the gas control knob (3) to "OFF" (∩) and call your local service technician or gas supplier.

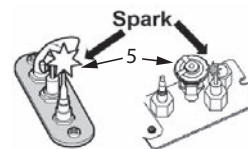

**Fig 3**

Reinstall the window and set the MAN-knob (2) to "ON"; turn Flame Adjustment knob (3) up (∩) or down manually or use the up/down 'flame' buttons on the remote control handset to adjust the flame height.

## TO TURN OFF GAS TO APPLIANCE

1. AUTOMATIC SHUT-OFF (using the remote control handset):

- Press and hold the  (small flame) on the remote control handset to shut-off the main burner gas flow;
- Press "OFF" button on remote handset to shut-off the appliance, including pilot flame.

2. MANUAL SHUT-OFF (using only the ON/OFF switch (1))

- Press "O" the ON/OFF switch (1) to shut-off the appliance.



### Servicing Your Fireplace

We recommend having your fireplace serviced every year. Contact your supplier quoting the model number. It will be helpful if the appliance's serial number can also be quoted. These numbers are on the information card. The replacement parts are shown at the end of this manual. Please always quote the part number and description when requesting spare parts.

#### Annual Inspection

In order to maintain the safe operation of your fireplace, contact your dealer to have a qualified technician go over the list below and make the necessary verifications at least once every year.

### Safe Operation List

To be performed by a qualified technician only

1. Inspect and operate the pressure relief mechanism to verify relief mechanisms are free from obstruction to operate. See *Cleaning Your Fireplace: To refit the window* section of this manual.
2. Clean glass window with a suitable fireplace glass cleaner. Abrasive cleaners must not be used. Be careful not to scratch the glass when cleaning. See *Cleaning Your Fireplace* section of this manual.
3. Inspect the operation of the flame safety system Pilot or Flame rectification device.
4. Inspect and ensure the lighting of the main burner occurs within 4 seconds of the main gas valve opening. Visual inspection should match that outlined in the appliance instruction manual. Inspect primary air openings for blockage. See *Checking Pilot and Burner Flame* section of this manual.
5. Inspect condition of vent and vent terminal for sooting or obstruction and correct if present.
6. Vacuum and clean any debris in the firebox that is not supposed to be there.
7. Test and measure the flame failure response time of the flame safety system. It must de-energize the safety shutoff in no more than 30 seconds.
8. Check all accessible gas-carrying tubes, connections, pipes and other components for leaks. See *Set up Gas Supply* section of this manual.

### Cleaning Your Fireplace

#### **⚠ WARNING**

**DO NOT TOUCH THE GLASS WHILE IT IS HOT!**

Let the fireplace cool first before cleaning it.

#### **Important - Glass cleaning - Mineral deposits**

One of the by-products of the combustion process in a gas appliance is a mineral which can show up as a white film on the ceramic glass of the viewing door.

The composition of the deposit varies with location and time. It is believed to be associated with the varying sulfur content of the gas. You may have the problem intermittently.

We have consulted with ceramic glass manufacturers and they cannot offer a definitive solution to this problem. Dealers have tried various cleaning products with varying results. The following are recommendations only and are not meant to guarantee results.

**NOTE: This is a problem beyond Miles Industries' control and is not covered under warranty.**

- Clean the glass regularly as soon as you notice the buildup (white film). If the film is left for a longer period of time, it will etch into the glass. It is then much harder, if not impossible, to remove.
- **NEVER use an abrasive cleaner or ammonia-based cleaner on the ceramic glass.** Any abrasion of the surface has the immediate effect of compromising the strength of the glass. An emulsion type cleaner is recommended.
- Use a soft damp cloth to apply the cleaner. Dry the glass with a soft, dry, preferably cotton cloth. Most paper towels and synthetic materials are abrasive to ceramic glass and should be avoided.
- Our dealers have had good results from the products listed below. We cannot, however, guarantee the results of these products.
  - Brasso, Polish Plus by Kelkem, Cook Top Clean Creme by Elco, White Off by Rutland, Turtle Wax

#### ***Do not clean the glass while it is hot!***

Always securely replace the window and the barrier screen before lighting.

**If broken, the glass pane may only be replaced as a complete window unit as supplied by the manufacturer.**

**If the barrier becomes damaged, the barrier shall be replaced with the manufacturer's barrier for this appliance.**

Clean the window panes following the guidelines in this section.

Clean the steel trim with mild soap and warm water. Any alcohol/solvent base cleaner will weaken the coating and damage it.

Clean the barrier screen dusting it with a soft brush.

Clean the firebox ceramic logs/rocks and walls dusting them with a soft brush. Dust can also be removed from the burner using a soft brush after removing the fuel bed. **When cleaning, make sure that no particles are brushed into the slots of the burner.**

#### **To remove the window for cleaning:**

1. Unhook the front or trim with barrier screen attached.
2. Turn the top two spring-loaded window bolts through 90 degrees to release the window from the firebox.
3. Remove the bottom two spring-loaded window bolts.

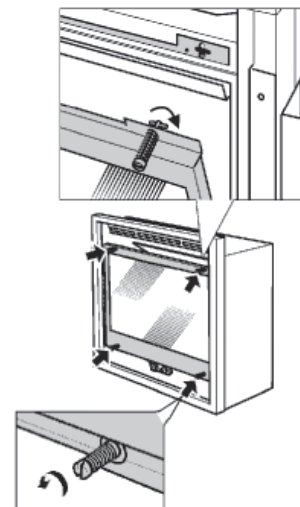

Window opening & removal

4. Carefully lift the window away. Keep the window and bolts in a safe place.

## Servicing & Maintenance

To refit the window:

### **! DANGER**

The window unit must be correctly installed, fastened and sealed after servicing or serious bodily injury and/or damage to the appliance may result.

To ensure a safe operation:

- Double-check that the window frame is correctly installed;
- Verify that the bolts and spring-loaded bolts are hooked properly to the window tabs then;
- Pull out the top of the window and release it to insure the springs return it;
- Ensure the window is sealed before operation.

### **! WARNING**

Failure to install the window correctly can leak carbon monoxide, affect the performance of the fireplace, damage components, cause overheating resulting in dangerous conditions. Damage caused by incorrect window installation is not covered by the Valor warranty.

1. Refit the window with the bottom two bolts. The bolts should be screwed in securely.
2. Refit the top two bolts securing by turning them through 90 degrees.

3. Pull the top of the window forward and release to check that it opens slightly and returns confirming the good function of the spring-loaded mechanism.
4. Similarly check the bottom of the window by pulling it forward and releasing.

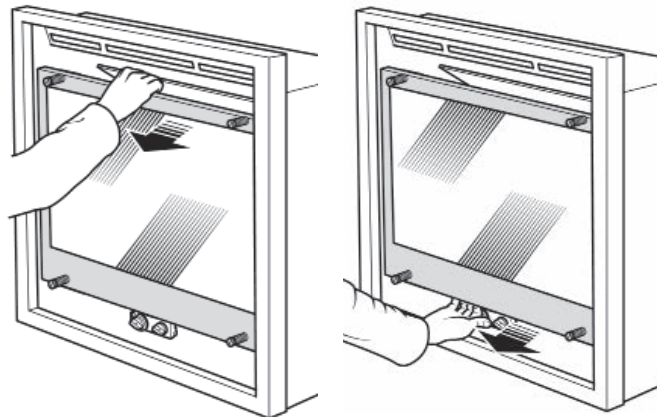

5. Apply firm hand pressure around the window frame to ensure the window is sealed tight against the firebox.
6. If the Hot Glass Warning plate has been removed from the front lower corner of the window, reinstall it by sliding it between the glass and the frame as indicated.

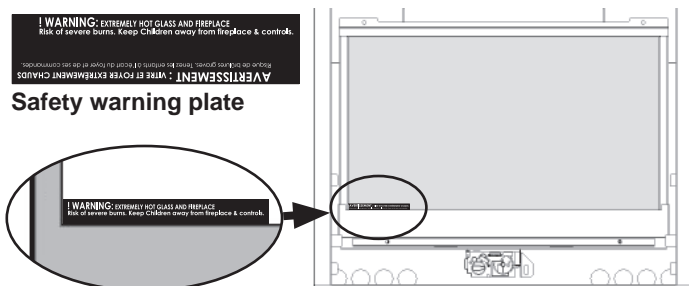

7. Replace the front or trim with the barrier screen attached.

### **! WARNING**

**FOR SAFETY PURPOSE**, ensure the barrier screen is re-installed on the fireplace front after maintenance.

## Servicing & Maintenance

### Checking Pilot and Burner Flames

A periodic check of the pilot and burner flames should be made. Check after the fire has been on for at least 30 minutes. The pilot flame must cover the tip of the thermocouple probe. The main burner flame pattern will vary from appliance to appliance depending on the type of installation and climatic conditions.

The appliance area must always be kept clear and free from combustible materials, gasoline and other flammable vapors and liquids. Inspect the vent terminal outdoors regularly to make sure that dirt, snow, insects, leaves, shrubs, trees do not obstruct it. Examine the whole vent system regularly. We recommend annually.

#### Correct flame appearance



534LSK—Traditional Logs



534DWK—Driftwood



534RSK—Rocks

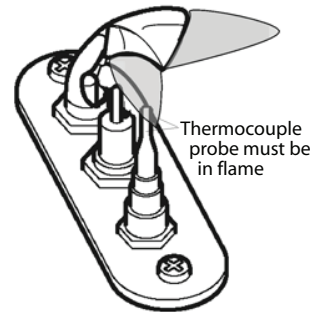

Pilot Flame can be seen on the left side of the fuel bed



#### Rock fuel bed

A black discoloration may form over time at the front bottom of the 6-rock original fuel bed; this deposit can be burned off by running the fireplace on a low to medium setting fire for 30 to 45 minutes. This discoloration is unavoidable and will re-form again.

**Replacing Batteries**

**⚠ WARNING**

**DO NOT ATTEMPT TO CHANGE THE BATTERIES WHILE THE FIREPLACE IS STILL HOT!** Let the fireplace cool first before touching it.

**CAUTION**

**DO NOT USE** a screwdriver or other metallic object to remove the batteries from the battery holder or the handset! This could cause a short circuit to the receiver.

**Low battery signal: see page 11.**

**BEFORE changing the batteries, turn off the valve using the manual On/Off switch**—see instructions on page 7.

The appliance uses four 1.5 V AA **alkaline** batteries for its remote control receiver battery holder and one 9 V **alkaline** battery for its handset. The batteries should last one to two seasons, depending on usage. Removing the batteries in the off-season will extend the battery life. Should the batteries lose power, the control may be operated by manually turning the control knob at the valve or by turning off the valve at the switch.

**To replace the batteries in the battery holder**

1. The battery holder is located below the firebox, usually on the right hand side (depending on your installation). Remove the front trim. Grab the battery holder and pull it out from its location.

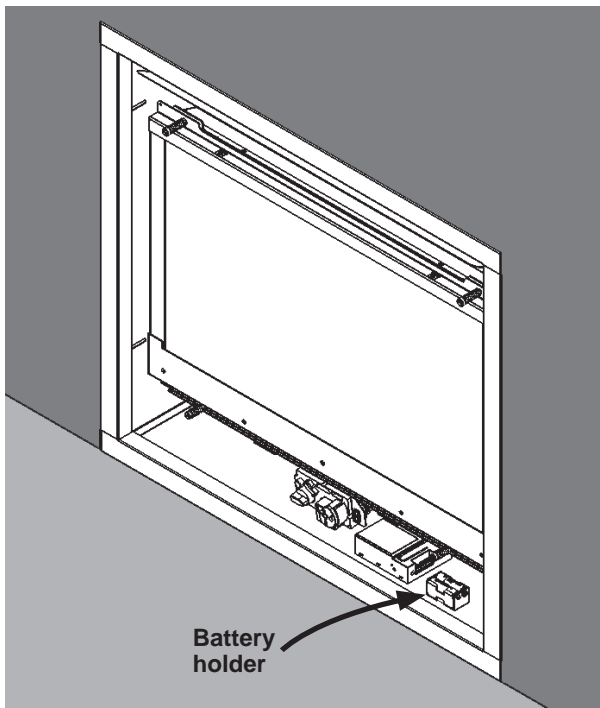

2. Disconnect the battery holder from the cable.

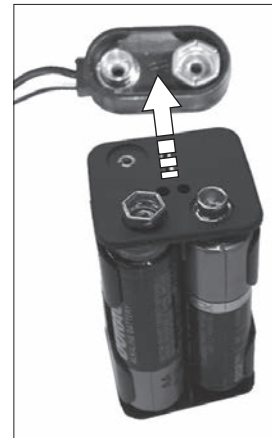

3. Replace the batteries with 4 AA **alkaline** batteries.
4. Reconnect the cable.
5. Put the battery holder back in its position.

**CAUTION**

Do not let the cable touch the underside of the burner plate. It will melt during operation.

6. Reinstall the front trim.

**Using Handset Wall Holder**

Your fireplace equipment includes a wall holder to store the handset. If it hasn't been installed, refer to the instructions further on in this manual for the installation.





# Specifications

## Approvals & codes

These appliances are certified by ANSI Z21.88 / CSA 2.33 American National Standard / CSA Standard for *Vented Gas Fireplace Heaters* for use in Canada and USA. These appliances are for installation directly venting through an outside wall or through the roof.

Conversion between fuels may only be done using the approved conversion kits listed in the section *Options*.

These appliances comply with CSA P.4.1-15 *Testing method for measuring annual fireplace efficiencies*.

The installation must conform with local codes or, in the absence of local codes with the *National Fuel Gas Code, ANSI Z223.1/NFPA 54* or the *Natural Gas and Propane Installation Code CAN/CGA-B149.1*. Only qualified licensed or trained personnel should install these appliances.

These appliances, when installed, must be electrically grounded in accordance with local codes or, in the absence of local codes, with the *National Electrical Code, ANSI/NFPA 70* or the *Canadian Electrical Code, CSA C22.1*.

## Ratings

Model	JN	JP
Gas	Natural	Propane
Altitude (Ft.)*	0-4,500 feet*	
Input Maximum (Btu/h)	24,000	24,000
Input Minimum (Btu/h)	6,500	13,000
Manifold Pressure (in w.c.)	3.95	10.0
Min. Supply Pressure (in w.c.)	5.0	11.0
Max. Supply Pressure (in w.c.)	11.0	14.0

\*Tested to CGA - 2.17-91 *High Altitude Standard in Canada*. In the USA, installations may require deration over 2000 feet—check local codes.

### \*High Altitude Installations

Input ratings are shown in BTU per hour and are certified without deration for elevations up to 4,500 feet (1,370 m) above sea level.

For elevations above 4,500 feet (1,370 m) in USA, installations must be in accordance with the current ANSI Z223.1 and/or local codes having jurisdiction. Heating value of gas in some areas is reduced to compensate for elevation—consult your local gas utility to confirm.

For installations at elevations above 4,500 feet (1,370 m) in Canada, please consult provincial and/or local authorities having jurisdiction.

## Supply Gas

Heater engine units 534JN is used with natural gas installations.

Heater engine units 534JP is used with propane gas installations.

The supply pressure must be between the limits shown in the table above.

The supply connection is 3/8 inch NPT.

The opening for the gas supply line is at the left side of the appliance.

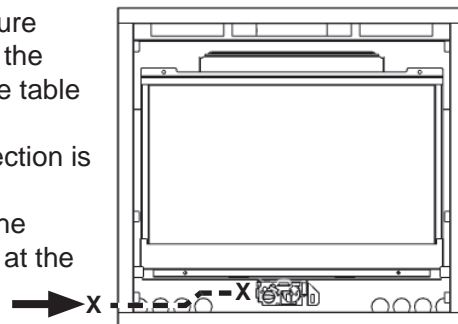

## Venting options

### Co-axial direct vent installations (solid piping)

A list of all approved venting accessories starts on page 48 of this manual.

NOTE: An 817VAK Vent Adapter is required in all cases.

### Co-linear direct vent installations (flexible piping)

Converts the appliance outlet collars to accept two 3-inch diameter flex liners for installation into existing solid-fuel burning fireplaces and chimneys. Requires a co-linear adapter at the appliance and either a co-linear terminal or co-linear-to-co-axial adapter and terminal at the top of the chimney. A list of approved venting accessories starts on page 48 of this manual.

## Outdoor Conversion Kit

The 534J model is supplied standard for indoor applications and may be adapted for installation in specific “outdoor” applications protected from weather as defined in the GV60CKO outdoor conversion kit manual.

## ⚠ WARNING

**Optional electrical accessories ARE NOT ALLOWED when adapting appliance for outdoor use.**

**This appliance is designed and approved as a supplemental heater and provides the potential for most energy conservation when used while attended. The use of an alternate primary heat source is advisable.**

# Overview

**Note:** This appliance may be installed in outdoor, weather protected environments as defined in the GV60CKO Outdoor Conversion Kit instruction manual.

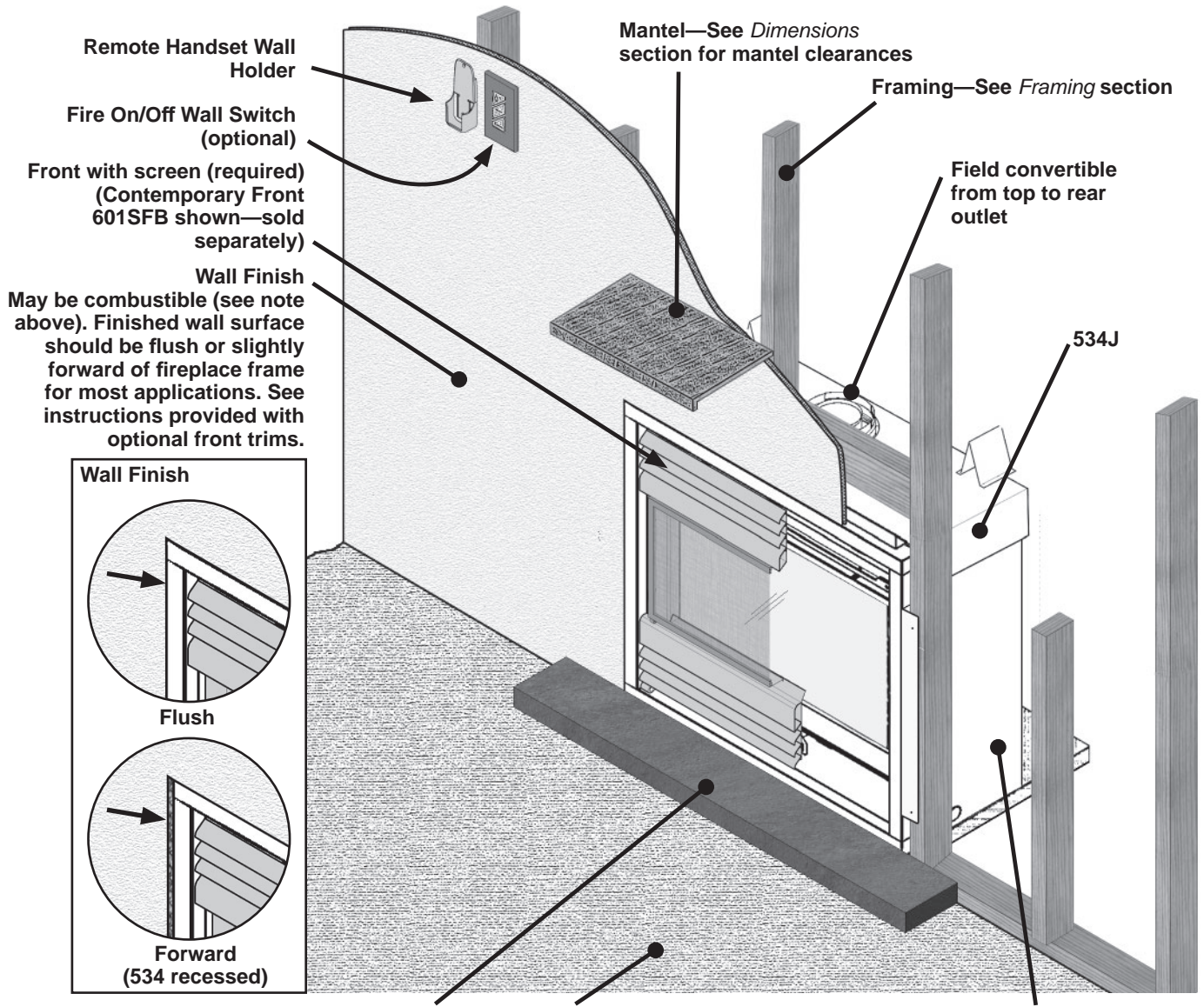

Hearth (if used) may be combustible. Install the bottom of the heater flush with the top of finished hearth for most applications. See instructions provided with optional front trims.

Combustible Floor

Combustible framing allowed beneath fireplace. When the appliance is installed directly on carpeting, tile or other combustible material other than wood flooring, the appliance shall be installed on a metal or wood panel extending the full width and depth of the appliance.

## **⚠ WARNING**

Some materials or items, although safe, may discolor, shrink, warp, crack, peel, and so on because of the heat produced by the fireplace. Avoid placing candles, paintings, photos, and other items sensitive to heat around the fireplace.

## **⚠ WARNING**

**HOT HEARTH / FLOOR!** The hearth or floor in front of the fireplace may become very hot when the fireplace heats. Do not use the hearth as a seat or shelf. Solid wood flooring in front of the fireplace (if allowed) may shrink during the heating season due to heat.

# Dimensions

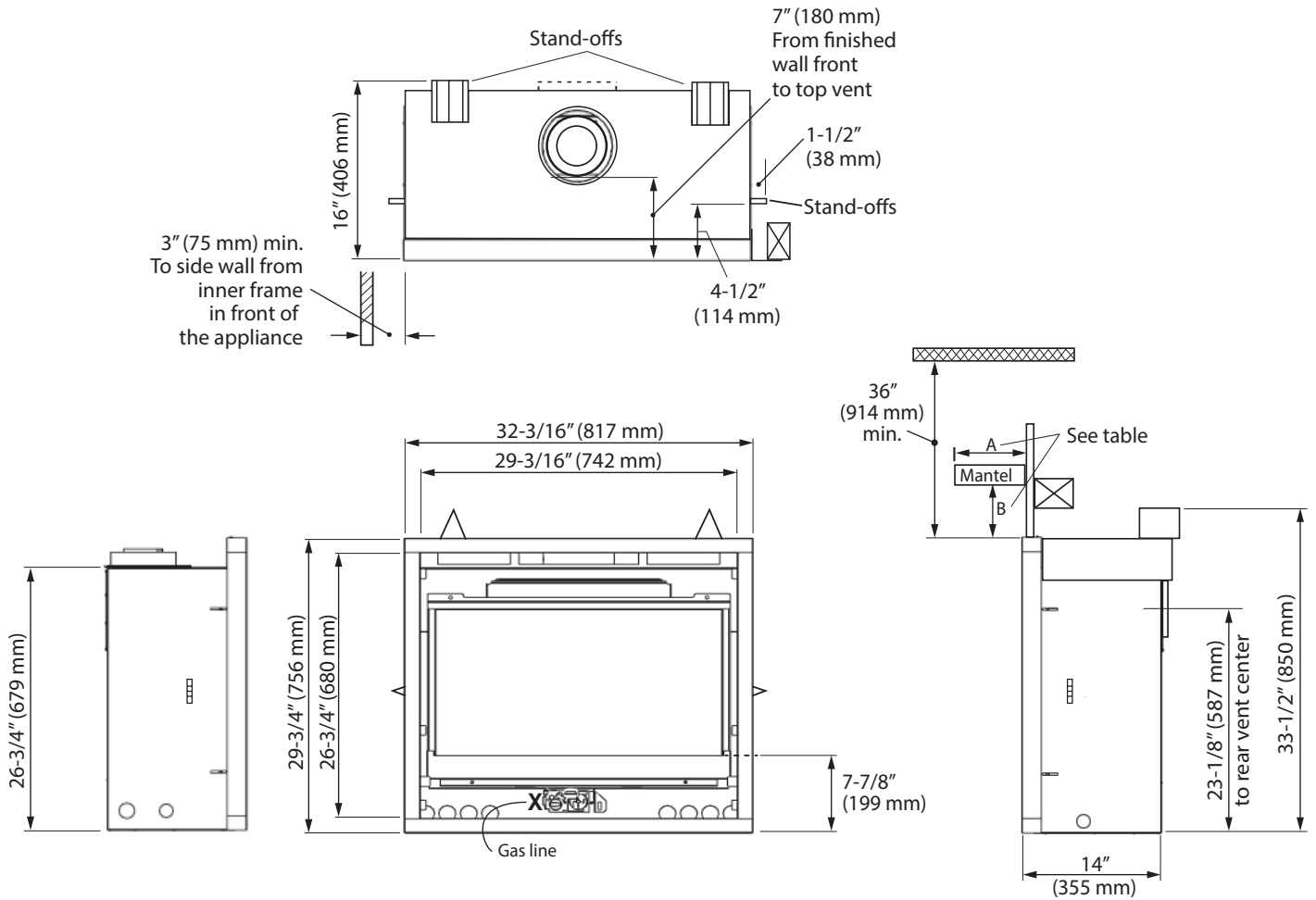

Mantel depth "A"	1" (25 mm)	2" (51 mm)	3" (76 mm)	4"-5" (102-127 mm)	6" (152 mm)	7" (178 mm)	8"-12" max. (203-305 mm) max.
Mantel clearance "B"	7" (178 mm)	8" (203 mm)	9" (229 mm)	10" (254 mm)	11" (279 mm)	12" (305 mm)	14" (356 mm)

## Fronts and Trims

For fronts and trims dimensions, refer to instructions provided with each kit.

## Floor/Hearth

This appliance is approved for installation directly on combustible material such as plywood and so on. Vinyl, carpet, and soft flooring require sheet metal extending the whole width and depth under the appliance. This appliance does not require a hearth. Combustible flooring may extend up to the front of the unit.

## Combustible Materials Specifications

Materials made of or surfaced with wood, compressed paper, plant fibers, plastics, or other material that can ignite and burn, whether flame proofed or not, or plastered or unplastered shall be considered combustible materials.

## Non-Combustible Materials Specifications

Material which will not ignite and burn. Such materials are those consisting entirely of steel, iron, brick, tile, concrete, slate, glass or plasters, or any combination thereof.

Materials that are reported as passing ASTM E 136, Standard Test Method for Behavior of Materials in a Vertical Tube Furnace at 750 °C shall be considered non-combustible materials.

## Framing

- A non-combustible hearth is not necessary in front of this appliance.
- Note that the unit is installed at the framing stage and fixed to framing using support angles. See page 32. Wall finish is then installed afterwards over the support angles and up to the perimeter of the unit.

**When the appliance is installed directly on carpeting, tile or other combustible material other than wood flooring, the appliance shall be installed on a metal or wood panel extending the full width and depth of the appliance.**

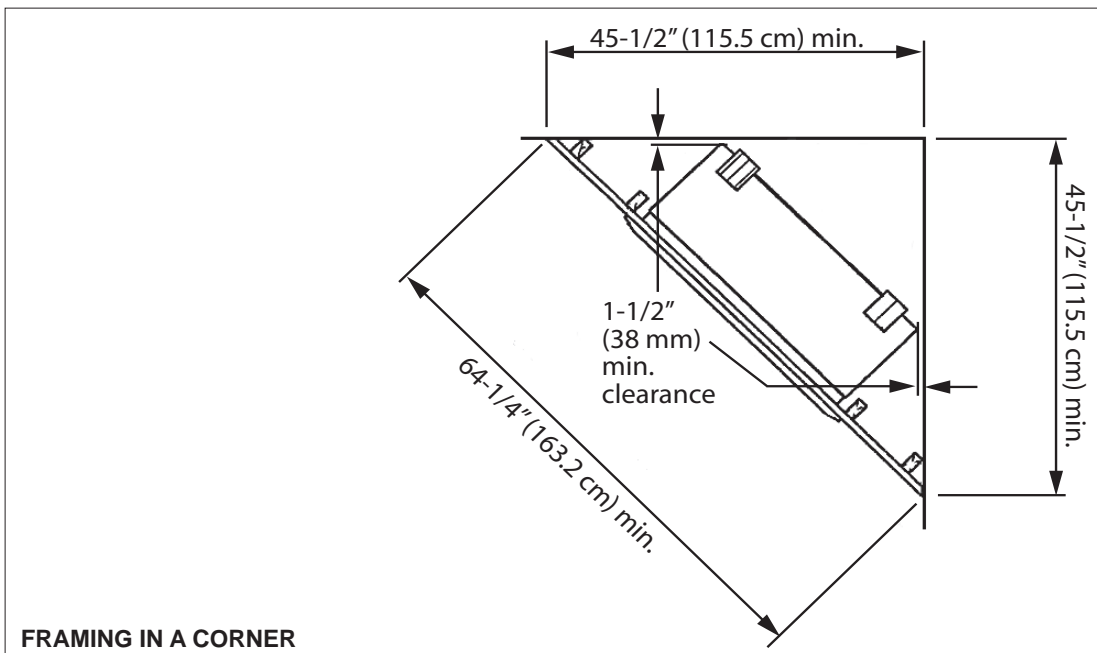
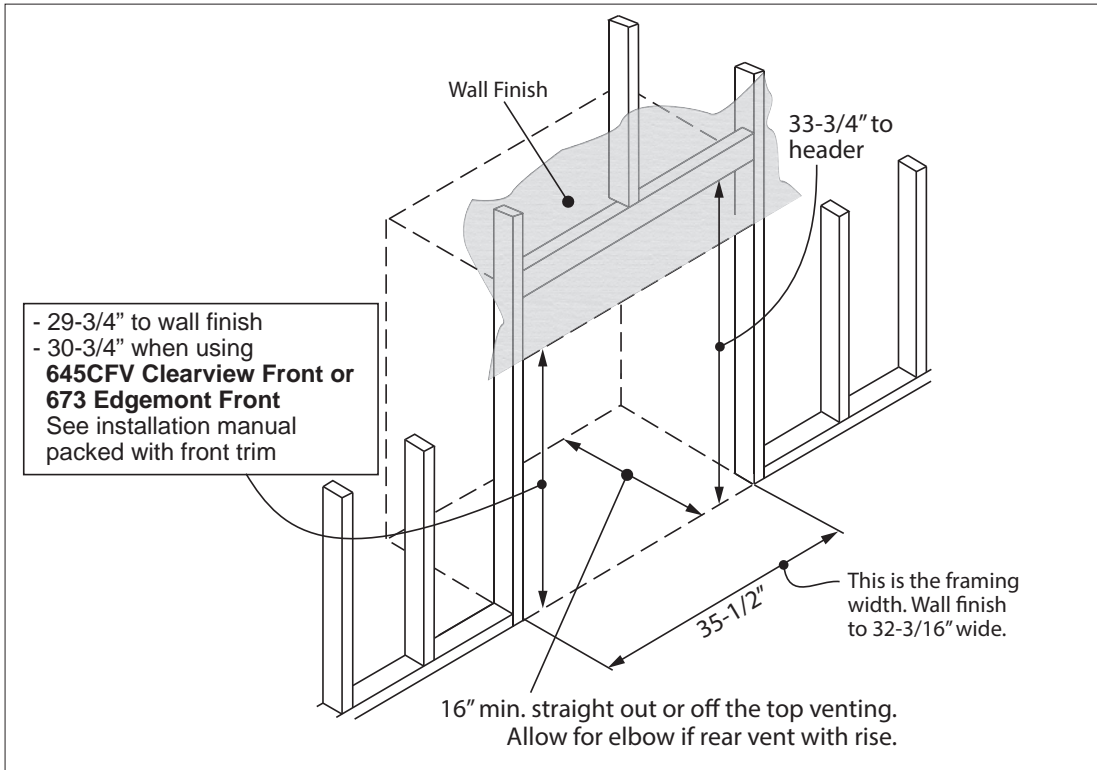



## Location

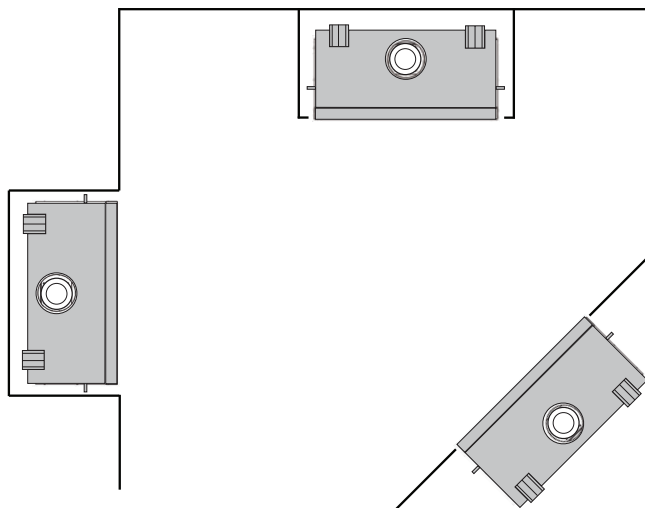

## Venting

### Vent Material

This unit is approved for installation using 4 x 6-5/8 inches approved co-axial direct vent pipes and accessories, see the list starting on page 48 of this guide. Follow the installation instructions supplied with the individual venting accessories.

This unit may also be converted to co-linear venting with two 3-inch pipes for use in solid-fuel burning fireplaces and chimneys using approved adapters and accessories. See list starting on page 48 of this guide.

### Wall Thickness

The appliance vent is suitable for penetrating a combustible wall assembly up to 14 inches in thickness. A non-combustible wall can be of any thickness up to the maximum horizontal run of vent pipe allowed for the particular installation.

### Vent Sealing

Seal all outer coaxial pipe and elbow joints, including sectioned elbow joints, using high quality, high temperature 2 inch wide self-adhesive aluminum foil tape (Nashua-322-2 brand or similar). Wrap the tape completely around all joints and press firmly to seal.

A high temperature black silicone sealant may be used in the outer joints as a substitute to foil tape.

Ensure all the pipe joints have a minimum of 1 ¼ inch overlap.

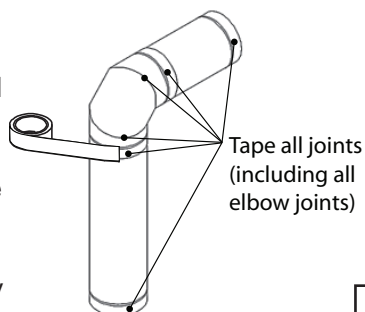

### Vent Penetration through Walls & Ceilings

**Combustible:** When penetrating through combustible walls and ceilings, frame a minimum of 10 inch x 10 inch opening and ensure that the insulation is kept clear of the vent pipe using either a wall thimble or an attic insulation shield. Follow the installation instructions supplied with the individual venting components.

**Non-combustible:** If the wall is totally non-combustible (e.g. masonry block or concrete), mark for a 7 inch circular hole.

In both cases, the center of the hole should line up with the center line of the horizontal vent.

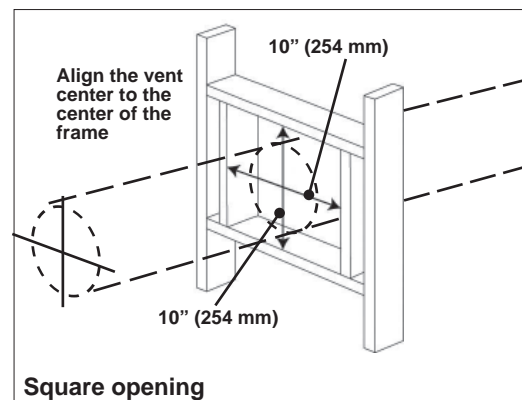

All horizontal pipe runs must be graded 1/4 inch per foot upwards in the direction of the exhaust flow. The final pipe length, when terminating through the wall may be graded downwards slightly to prevent water migration.



# Co-Axial Venting

## Typical Co-Axial Venting Components

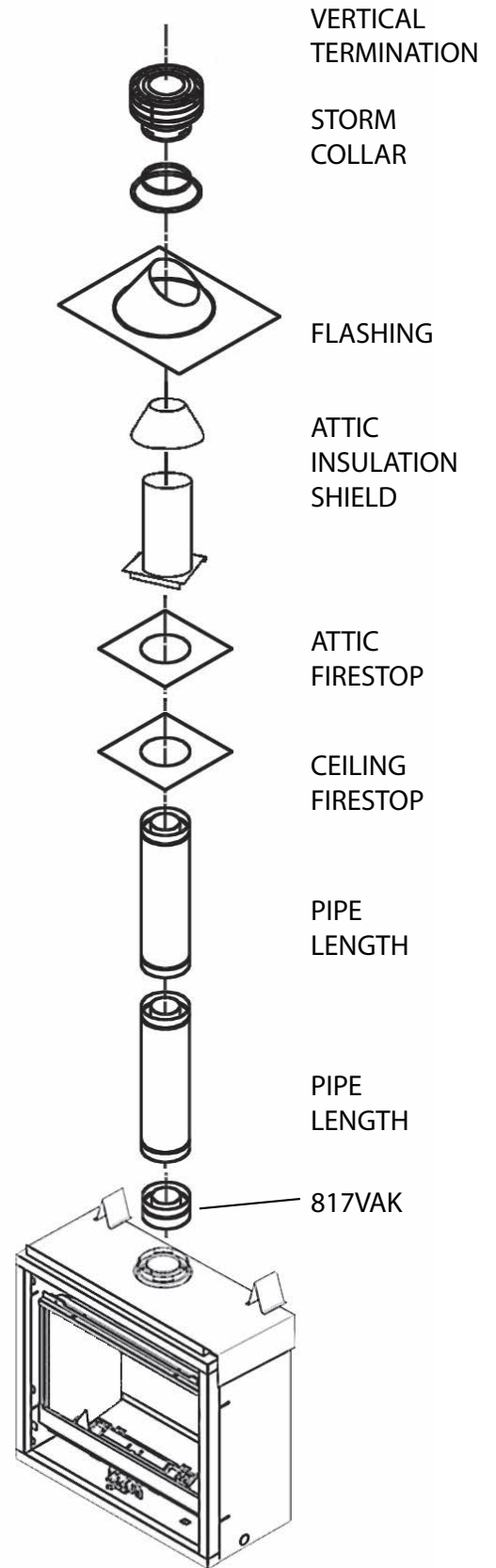
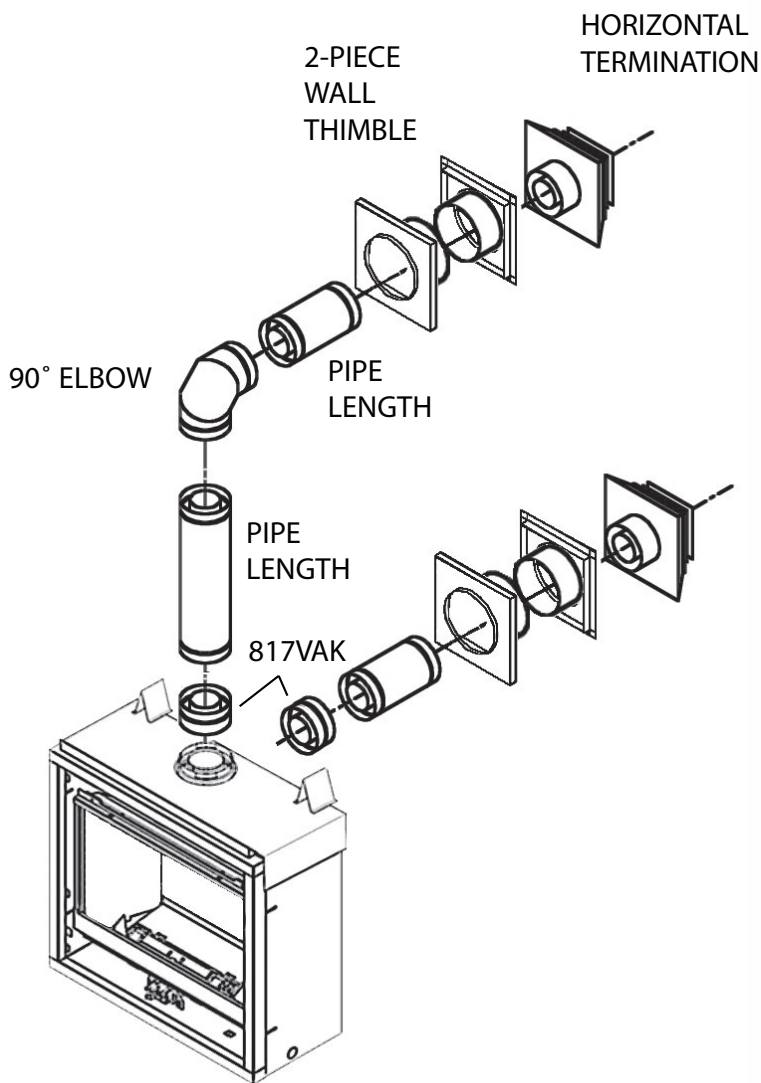

## Co-Axial Venting

### Rear Vent with No Vertical Rise

The horizontal vent run cannot be extended by the use of any vent accessory pipes.

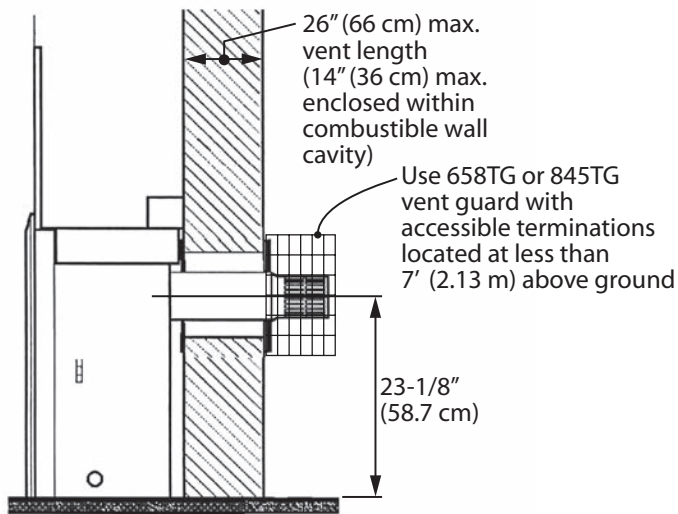

Rear vent—no vertical rise

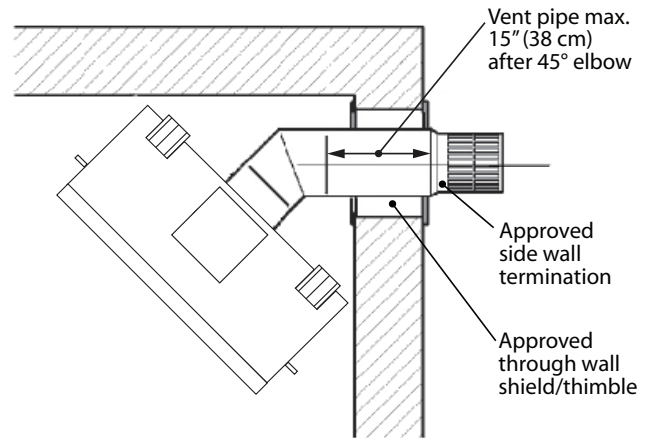

Corner rear vent—no vertical rise

### Important Installer Notice – Weather Sealing & Vapor Barriers

It is the installer's responsibility to ensure that vent installations through exterior walls are caulked and weatherproofed in such a manner as to:

- Prevent rain water from entering the wall from the weather side by adequately caulking the outer vent plate to the exterior wall surface.
- Prevent moisture inside the home from penetrating into the wall structure by ensuring the inside wall plate is adequately sealed to the inside vapor barrier.
- Prevent rain water and moisture from entering the walls by sealing the joints between the outer vent tube and the inner and outer wall plates.

We recommend the use of a high quality polyurethane sealant.

# Co-Axial Venting

## Horizontal Vent Termination Location

- The vent terminal must be located on an outside wall or through the roof.
- This direct vent appliance is designed to operate when an undisturbed airflow hits the outside vent terminal from any direction.
- The minimum clearances from this terminal that must be maintained when located on an outside wall are shown in figure below. Any reduction in these clearances could result in a disruption of the

airflow or a safety hazard. Local codes or regulations may require greater clearances.

- The vent terminal must not be recessed into a wall or siding.
- The vent terminal should be positioned where any snowdrifts will not cover it.
- Sidewall vent terminations require a terminal guard such as 658TG or 845TG when accessible—within 7' of ground.

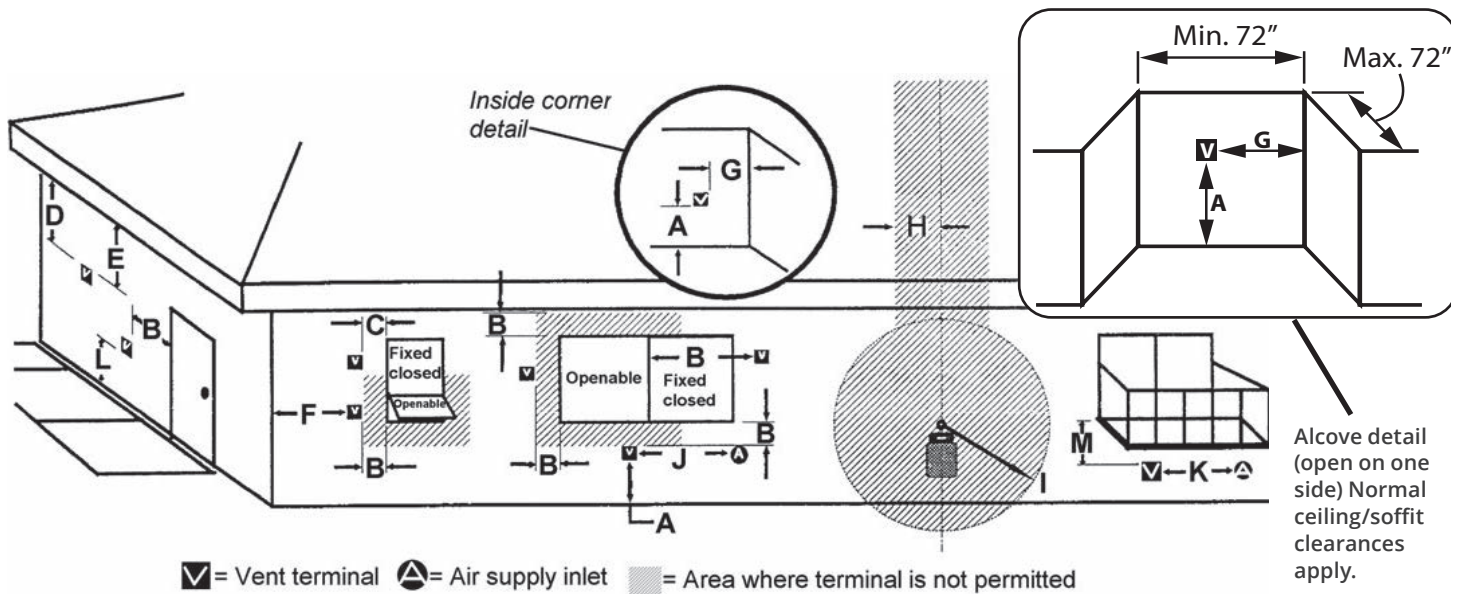

KEY	VENT TERMINAL LOCATIONS - MINIMUM DISTANCES Measured from the center of vent	MINIMUM CLEARANCE	
		Inches	Cm
A	Clearance above grade, verandah, porch, deck or balcony	12	30
B	Clearance to window or door that may be opened	12	30
C	Clearance to permanently closed window (recommended to prevent condensation on window)	12	30
D	Vertical clearance to ventilated soffit located above the terminal within a horizontal distance of 2 feet (60 cm) from the center-line of the terminal	18	46
E	Clearance to unventilated soffit	12	30
F	Clearance to outside corner	12	30
G	Clearance to inside corner	12	30
H	Horizontal clearance to center-line of meter/regulator assembly located within 15 feet (4.6 m) below the terminal	36	90
I	Clearance to service regulator vent outlet	36	90
J	Clearance to non-mechanical air supply inlet to the building or the combustion air inlet to any other appliance	12	30
K	Clearance to a mechanical air supply inlet	72	180
L	Clearance above paved sidewalk or a paved driveway located on public property <b>Note: A vent must not terminate directly above a sidewalk or paved driveway, which is located between two single-family dwellings and serves both dwellings. THIS DOES NOT APPLY to direct vent, non-condensing appliances in the Province of Ontario.</b>	84	210
M	Clearance under a verandah, porch, deck or balcony <b>Only permitted if veranda, porch, deck or balcony is fully open on a minimum of 2 sides beneath the floor</b>	12	30

Note: Local codes and regulations may require different clearances.

# Co-Axial Venting

## Co-Axial Venting Configurations with Vertical Rise

4 x 90° ELBOWS MAXIMUM  
(or equivalent)

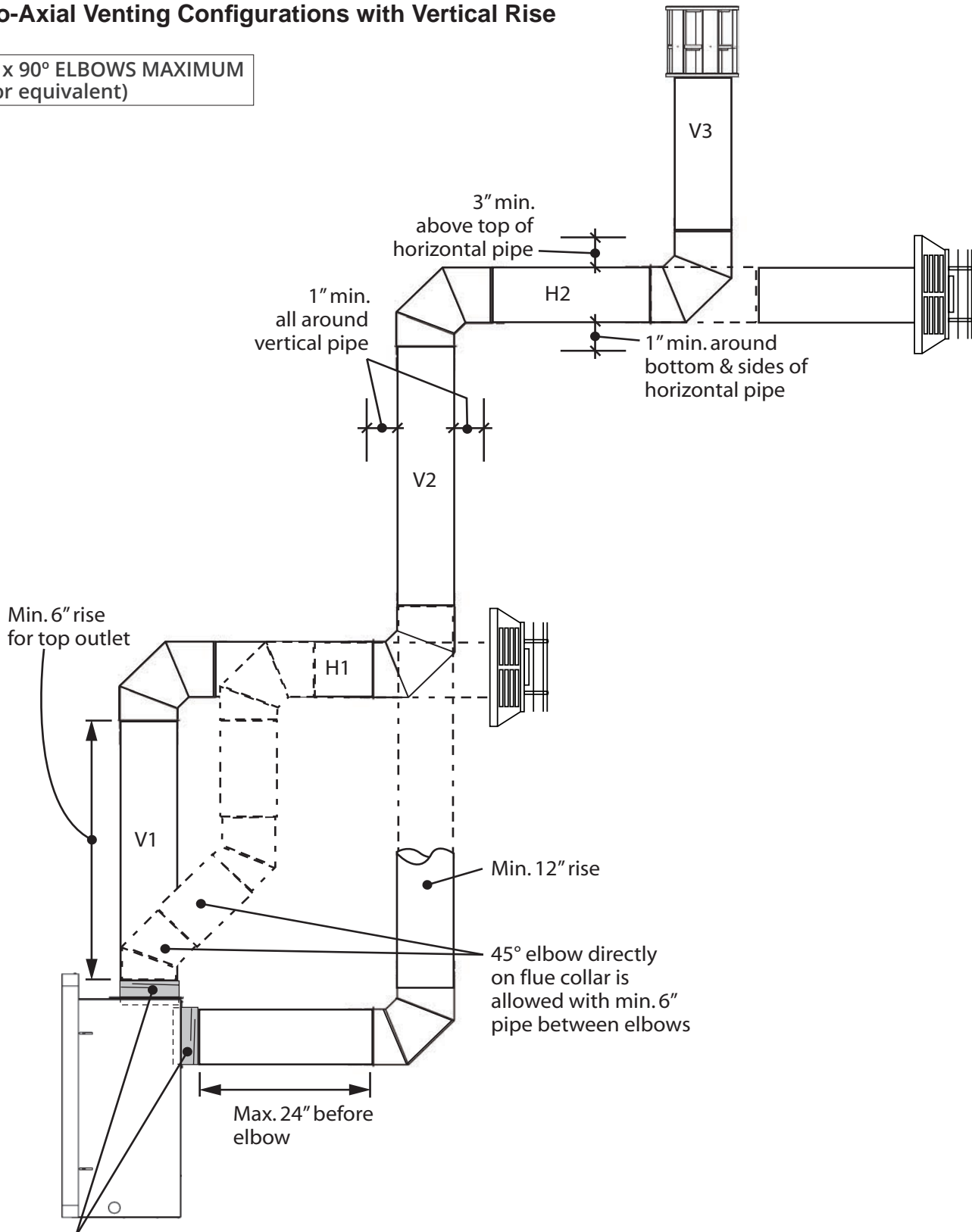

817VAK adapter:  
required for top  
or rear outlet.

### Example 1

$$V \text{ Value} = V1 (6') + V2 (6') + V3 (2') = 14'$$

$$H \text{ Value} = H1 (3') + H2 (3') = 6'$$

# Co-Axial Venting

## How to Read the Venting Chart

The chart below applies to co-axial roof or wall termination in installations with vertical rise. See page 25 for installations with no vertical rise.

1. The total length of the vent pipe cannot exceed 40 feet (12.2 m).
2. The minimum vertical height with roof termination is 10 feet (3.05 m).
3. Any combination of rise and run can be used as long as they are within the allowable limits shown on the chart below.
4. A maximum of 4 x 90 degrees elbows—or equivalent (2 x 45 degrees = 90 degrees)—can be used.

5. Each 90 degrees elbow installed on the horizontal plane is equivalent to a 3 feet horizontal pipe; therefore, 3 feet must be subtracted from allowable horizontal run. (45 degrees elbow is equivalent to 18 inches horizontal pipe.)
6. All horizontal pipe runs must be graded 1/4 inch per foot upwards in the direction of the exhaust flow. The final pipe length, when terminating through the wall may be graded downwards slightly to prevent water migration.
7. Maximum co-linear venting is 40 feet (12.2 m).
8. A restrictor is required for all installations—see section *Appliance Preparation* section for more information.

## Venting Chart—Allowable Co-Axial Vent Configurations with Vertical Rise

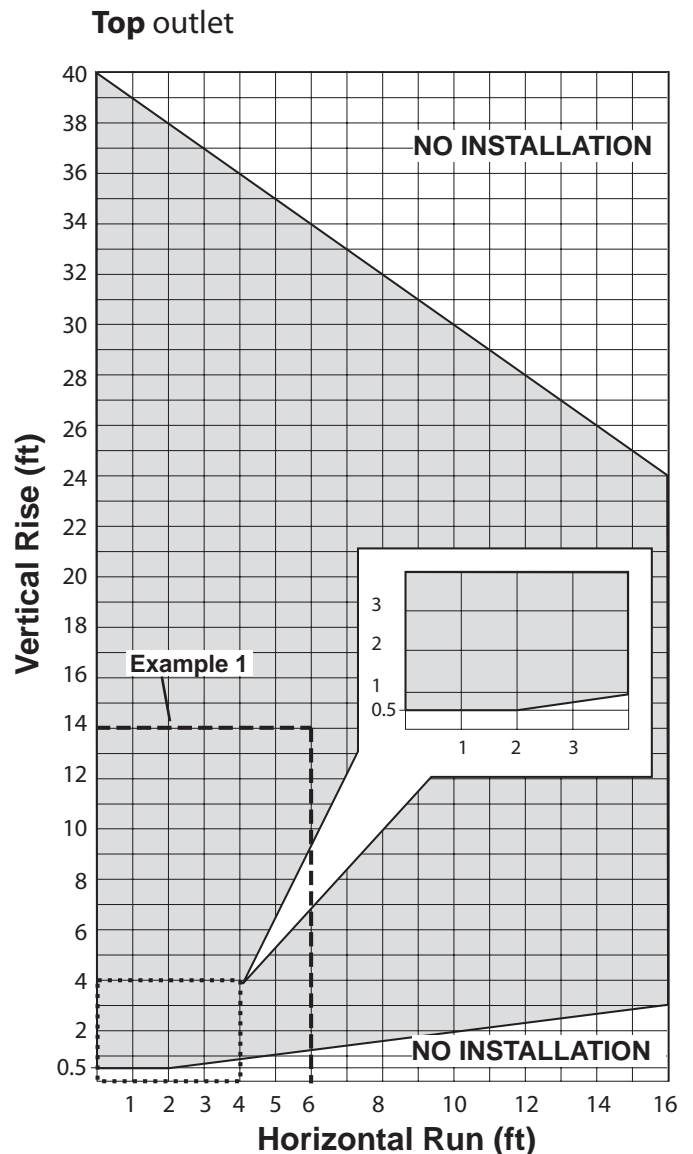
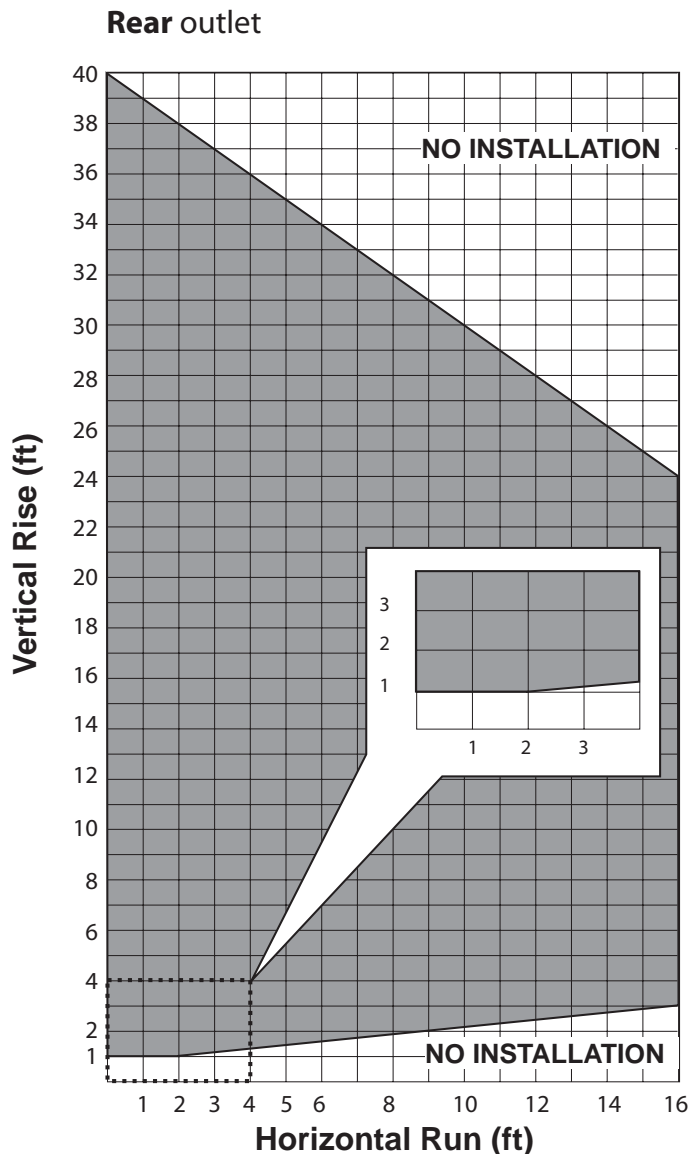



# Co-Axial Venting

## Co-Axial Vertical Installations

- Check the roof pitch to determine which roof flashing will be needed. See venting accessories list starting on page 48 for allowable components.
- The distance from the roof to the lowest terminal discharge opening ("H" in figure) depends on the roof pitch and must be in accordance with the manufacturer's instructions supplied with the termination unit.

*Note: The venting system for these appliances is considered to be a **Special Venting System**. The rule in the Installation Code requiring a minimum vent height of 2 feet above any portion of a building within 10 feet does not therefore apply.*

- The minimum clearances to combustible materials all round the vent pipes must be in accordance with the dimensions shown in the *Co-Axial Venting* section of this manual.
- Drop a plumb from the ceiling to the center of the appliance vent opening. Mark the position on the ceiling. Drill a small hole at the marked position.
- Determine the position where the vent will pass through the roof. If directly above the position where it penetrates the ceiling, drop a plumb from the roof to the small hole in the ceiling and mark the roof at this spot.

If rafters or other obstructions will prevent a vertical exit or if clear attic space is desired, the roof outlet can be offset using 45 degree elbows.

Drill a small hole at the marked position.

- A ceiling firestop must be installed at the second floor and higher floors. A ceiling support should be used below the flat ceiling.

To install the firestop and support, cut and frame a 10 inches (254 mm) square hole centered on the small hole previously drilled.

- Fit vent accessory elbows and pipe lengths as required up through ceiling support boxes and firestops. If installation includes offset, support the offsetting pipes every 3 feet (1 m) with wall straps as shown.
- Cut a hole in the roof centered on the small hole. The hole must allow for the minimum clearances to combustible materials. See *Venting* section in this manual.
- Fit pipe lengths through the roof. Fit roof flashing securing it with roofing nails.
- Fit storm collar and termination cap.

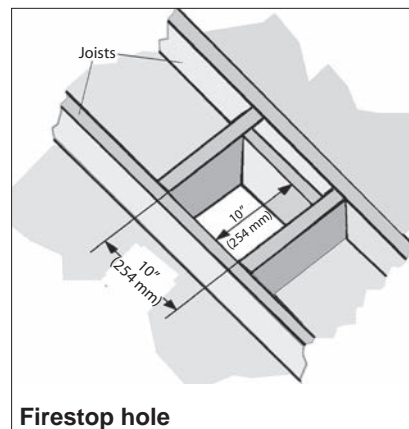
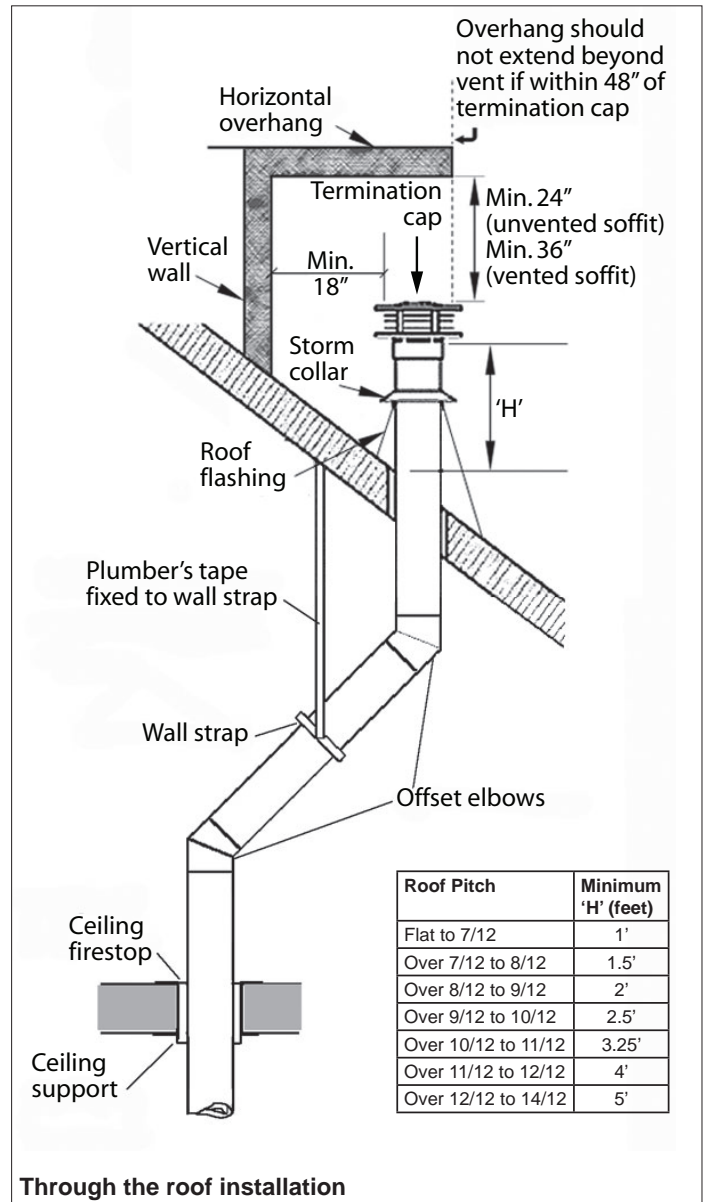

# Co-Linear Venting

## Co-Linear Vent Installations

- The chimney and fireplace opening sizes are shown in *Dimensions* and *Location* sections of this manual.
- Place the appliance (fitted with the co-linear adapter) near the fireplace opening but allow space for manipulating the chimney liners on to the appliance.
- Drop the 3-inch diameter flexible liners into the chimney from outside.
- Fit the liners to the co-linear adapter paying attention to inlet and exhaust and move the appliance to its proper position. Be aware of the minimum liner bend radius and maximum liner horizontal run as indicated at right.
- Fit the termination kit and flashing to the exterior of the chimney.

Secure the appliance to the floor or wall if necessary.

## Rear or Top Outlet Conversion to Co-Linear Liners using Valor 556CLA Co-Linear Adapter. (Generic co-axial to co-linear adapter boxes may also be used as an alternate to the 556CLA).

*Only for use when retrofitting a solid-fuel burning fireplace and chimney.*

The appliance must not be connected to a chimney flue serving a separate solid-fuel burning appliance.

Requires 556CLA Co-Axial to Co-Linear Appliance Adapter (or, alternatively, a generic adapter), two lengths of 3-inch diameter flexible chimney liner, co-linear termination kit and flashing and either high wind vertical vent terminal cap or a low profile vertical termination. *Zero Clearance stand-offs and shields supplied with the heater are not required for this application.*

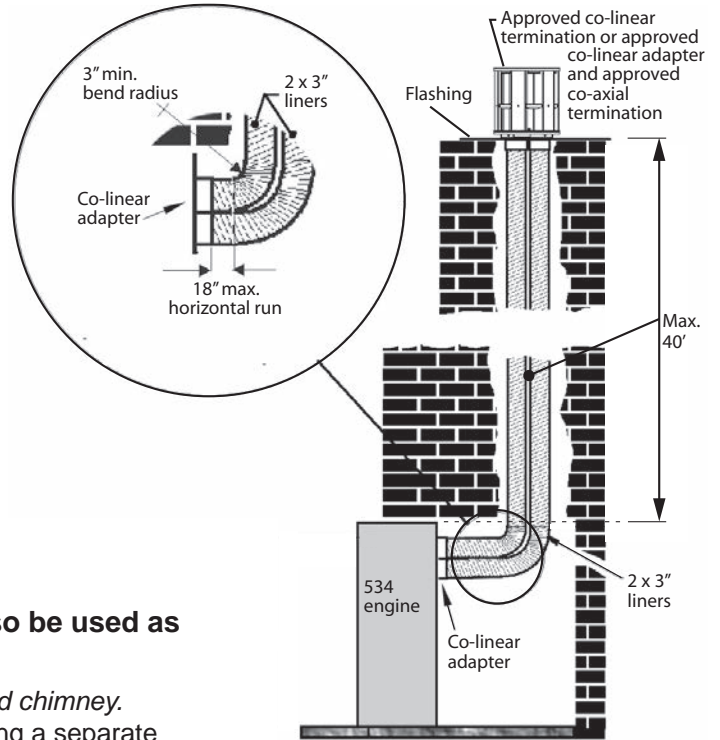

**Co-Linear installation into existing F/P**

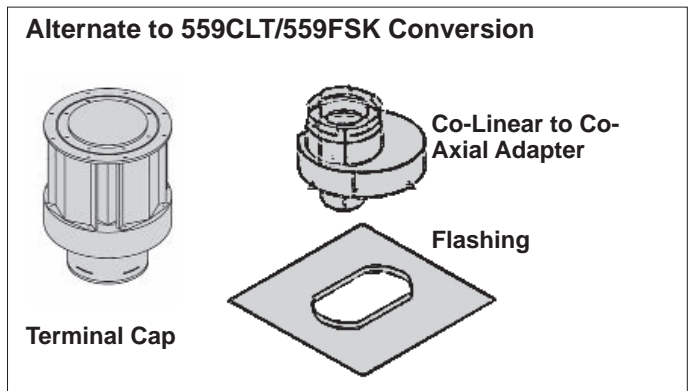
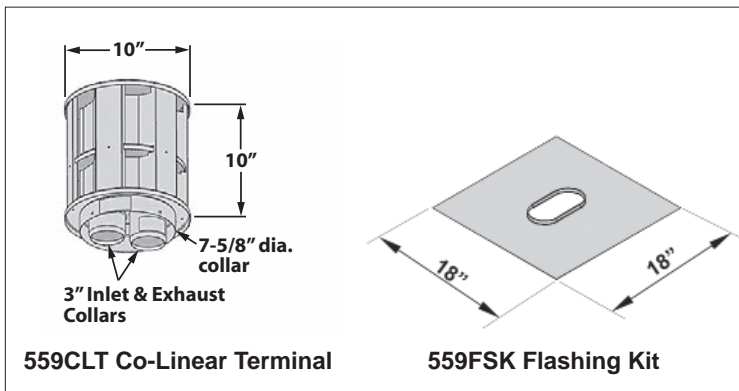
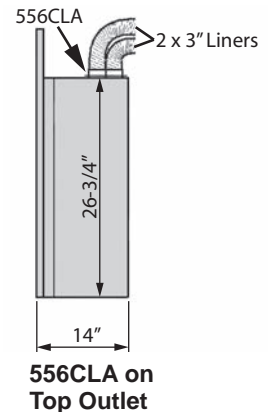
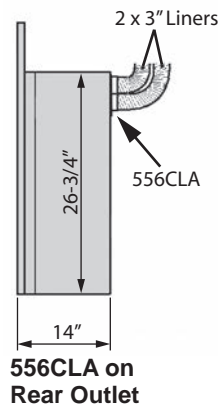
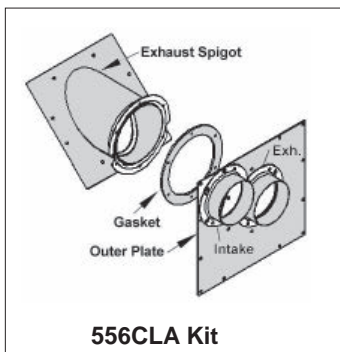

## Remove Window

1. Turn the top two spring-loaded window bolts through 90 degrees to release the window from the firebox.
2. Remove the bottom two spring-loaded window bolts.
3. Carefully lift the window away. Keep the window and bolts in a safe place.

## Convert to Rear Vent Outlet (if required)

*If installing with top vent outlet, ignore this stage.*

*If installing co-linear venting, see instructions supplied with the co-linear adapter.*

1. Remove the rear outlet cover plate and seal by unscrewing 12 screws. Keep the seal and plate for fitting to the top.
2. Remove the top outer vent collar and seal by unscrewing 12 screws.
3. Remove the top inner vent collar and seal by unscrewing 8 screws.
4. Locate the inner collar and seal inside the rear outlet opening. Secure the inner collar with 8 screws.
5. Fit the outer collar over inner collar. Loosely fit the 12 screws. Place the adapter 817VAK over the collars to check alignment. Tighten the 12 screws to secure the outer collar.
6. Fit the cover plate and seal (removed from the rear) to the top vent opening with 12 screws.

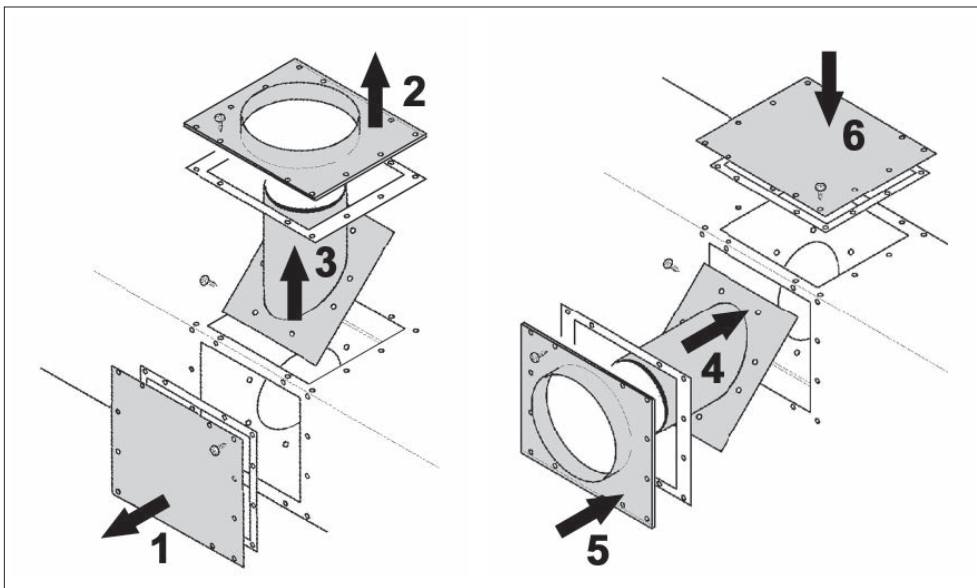
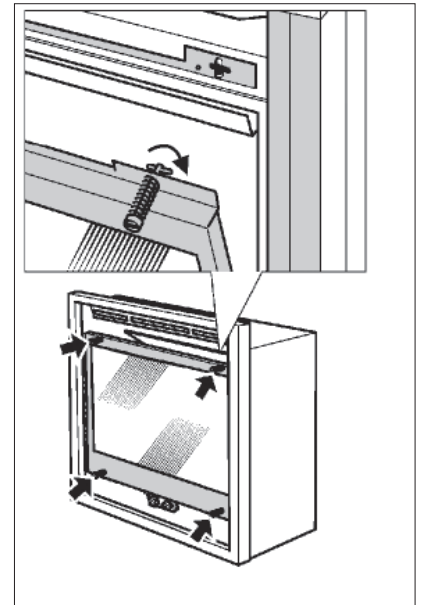

## Install 817VAK Vent Adapter

1. Fit the adapter 817VAK over the appliance vent collars pushing on firmly.
2. For rear vent outlet connection, align the adapter so that the seam on horizontal pipes is not at the bottom—check by temporarily fitting a pipe.
3. Drill through the adapter outer tube and appliance outer collar for no. 6 screws. *Make sure that the drill does not penetrate the inner tubes.*
4. Secure the adapter to the outer collar with two no. 6 thread-cutting screws supplied.

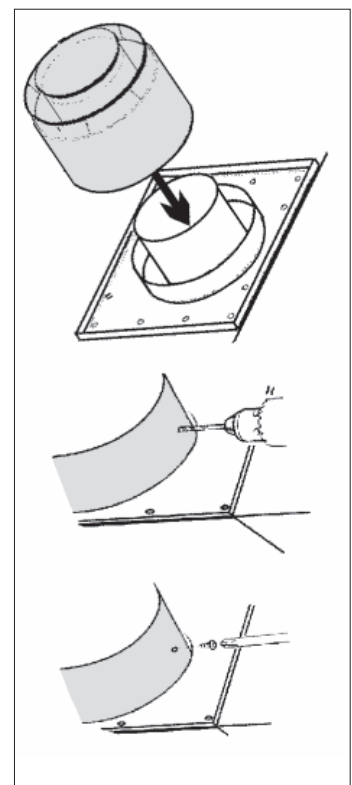

## Installation

### Install Top Heat Shield & Stand-offs

1. If installing appliance with top vent outlet, remove the plate covering the vent hole in the top heat shield by unscrewing four screws. **If installing with rear vent outlet, the plate must remain to cover the hole.**
2. Remove the screws at the top rear corner of the case sides.
3. If top vent outlet, locate the heat shield over the vent pipe adapter.
4. Support the front of the shield on the two angle supports.
5. Secure the shield to the case sides by refitting the two screws at the top rear corners and by two screws from the pack fitted near the front.
6. Bend the two top rear stand-offs and fit to the heat shield with three screws each.

**NOTE:** Zero clearance stand-offs and shield supplied with the heater are **not required for the co-linear application.**

### Install Support Angles

The distance from the wall angles to the front face of the heater case is adjustable between 3/8 inch (10 mm) and 1-3/16 inch (30 mm) to allow for a range of wall finish material thickness (e.g. tile, etc.).

*NOTE: When adding optional fronts and trims, it is important to install heater flush or slightly recessed into the **finished** wall surface.*

1. Fit the top angle support to the case top (3 screws).
2. Fit the two side angle supports (2 screws each). Fit the screws from inside the heater case.

### Remove Rear Log Support

Remove the rear log support to access to the rear orifices for restrictors installation (5 screws).

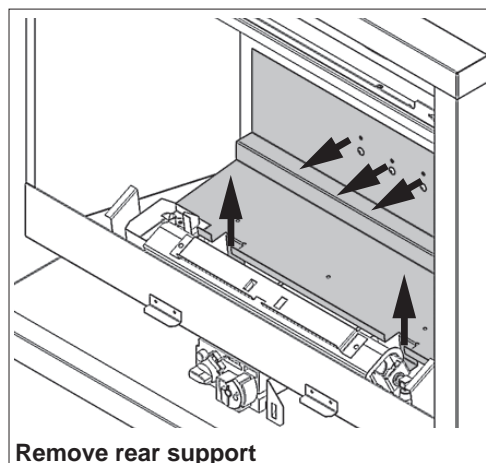
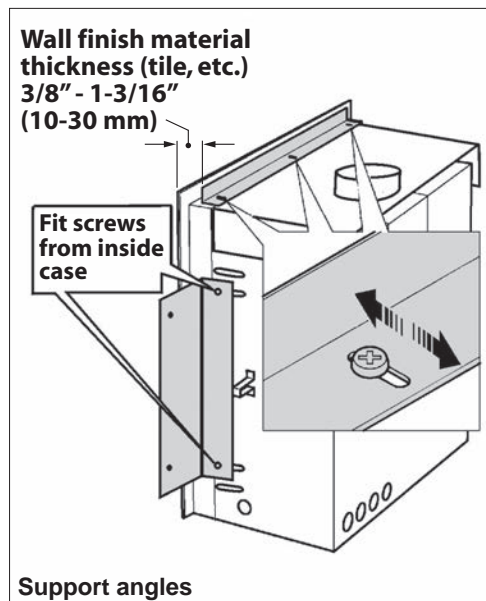
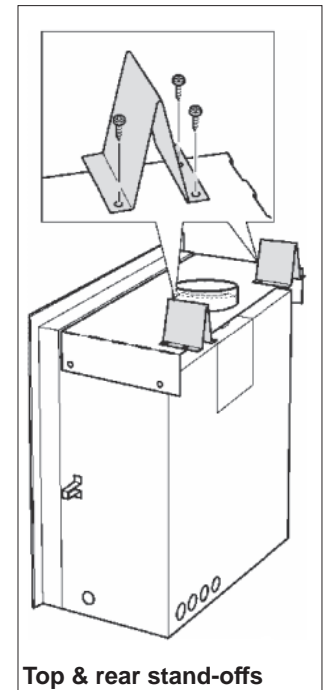
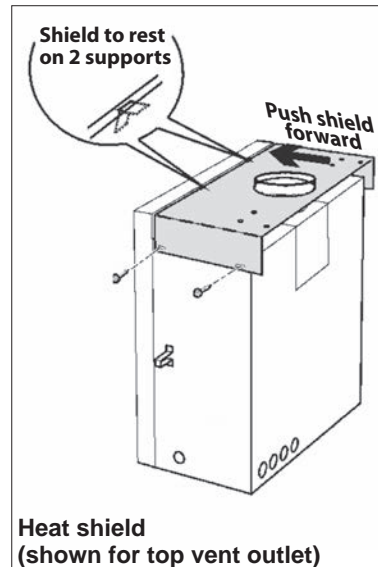



## Install Air Restrictors

**No restrictors are required for appliances which only have a horizontal vent run. If installing an appliance which has a rear vent outlet connection and no vertical vent pipe rise, ignore this stage.**

Two restrictor sets, like the one shown at right, are supplied with each 534 engine unit. The restrictors cover part of the **inlet air openings** in the firebox **rear wall** behind the rear log support. **Do NOT install the restrictors in the roof of the firebox!**

Each restrictor set includes an adjustable piece which can be moved to different positions depending of the vent configuration. See the table below to find out which position is optimal for each type of installation.

- To fit the restrictors, loosen the two center screws of the left and right inlet ports. Place the restrictor assembly under the screw heads and tighten the center screws.
- To set the adjustable restrictor piece, loosen the two screws, position the adjustable piece according to the diagram below and tighten the screws.

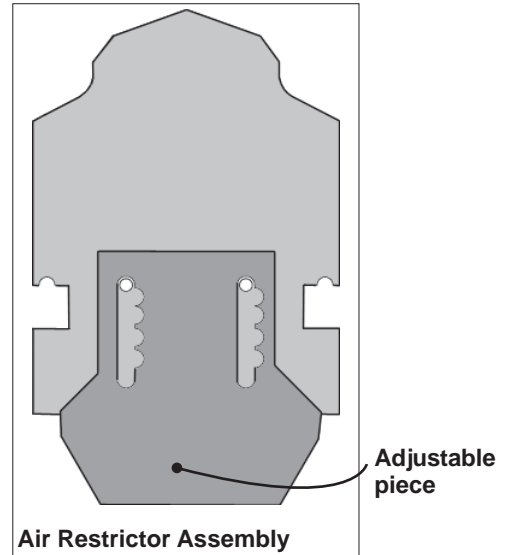

Vent terminal	Appliance vent outlet	Vertical vent pipe run	Use restrictor setting
Horizontal through wall with vertical rise  <b>No vertical rise = NO restrictor</b>	Top or Rear	Less than 6' (1.83 m)	
		From 6' (1.83 m) to 20' (6.1 m)	
		From 20' (6.1 m) to 40' (12.2 m)	

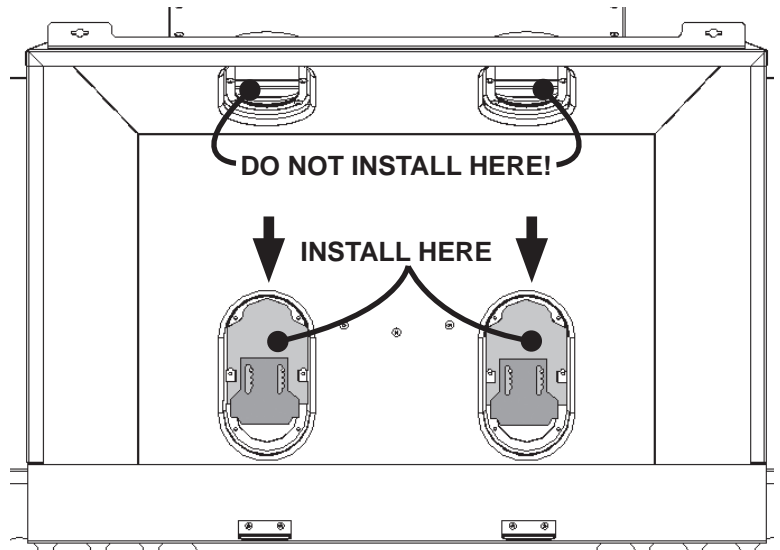

Vent terminal	Appliance vent outlet	Vertical vent pipe run	Use restrictor setting
Vertical through roof	Top or rear	Less than 20' (6.1 m)	
		From 20' (6.1 m) to 40' (12.2 m)	



## Installation

### Re-install Rear Log Support

Refit the rear log support in place (5 screws).

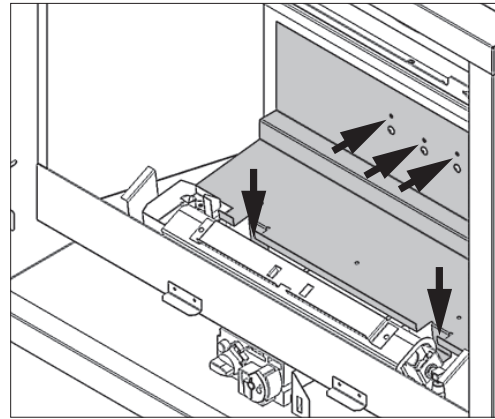

Reinstall rear support

### Install Appliance Into Framing

1. Place the heater in position in the framing.
2. Secure the side support angles to the side studding through two holes each side with the woodscrews supplied. The top support angle should abut the wall finish but is not fixed to the framing.
3. Check the wall finish requirements with the homeowner. If necessary, adjust the position of the heater so that the distance from the front of the heater case to the angles is suitable for the thickness of the wall finish (e.g. tile, etc.).

*NOTE: When adding optional fronts and trims, it is important to install heater flush or slightly recessed into the **finished** wall surface.*

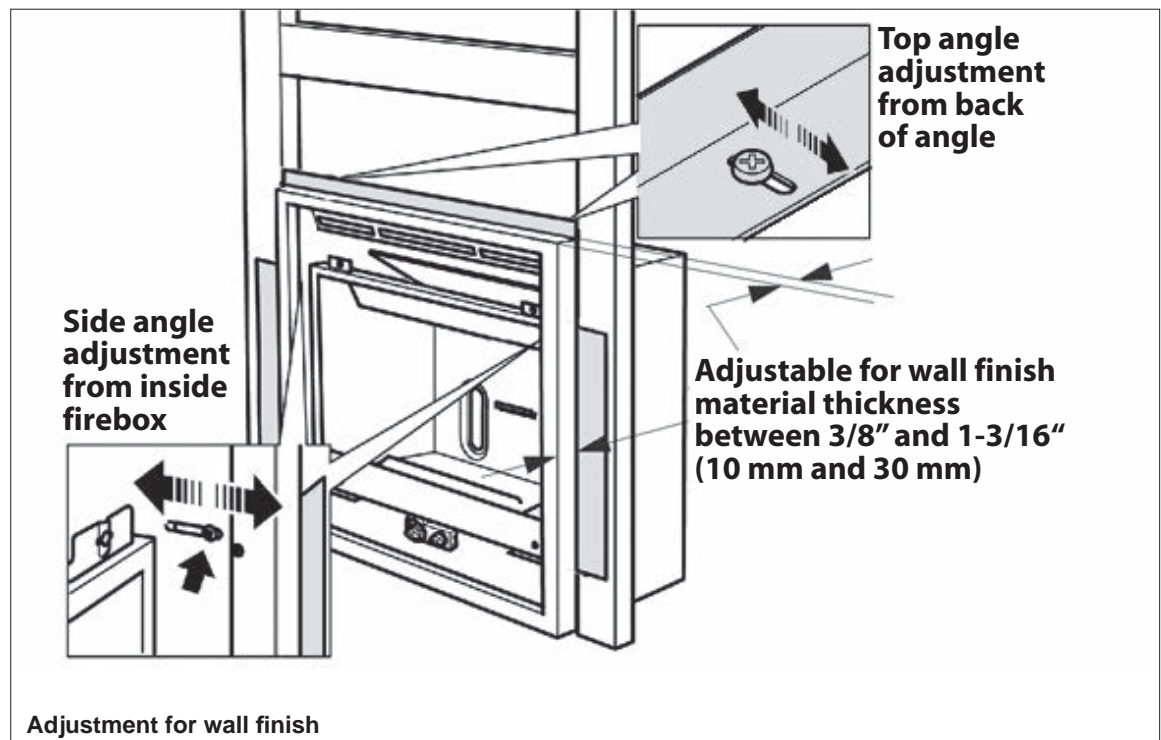

## Installation

### Connect Gas Supply

The gas supply pipe should enter the appliance case through the opening at the left side. The supply pipe should be connected to the appliance gas inlet pipe situated at the left side of the control valve. Supply line connection to the inlet pipe is 3/8 inch NPT

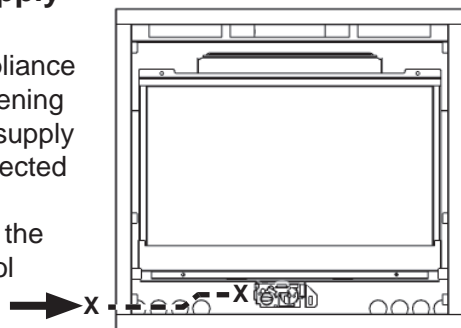

(female). **If the circulating fan is to be installed, be aware that the supply pipe inside the case should be at the same height as the appliance inlet pipe in order to clear the fan. If intending to fit an internal isolating valve, check that it will be clear wwoof the fan.**

Use only new black iron or steel pipes, CSST, or copper tubing if acceptable—check local codes. **Note that in USA, copper tubing must be internally tinned for protection against sulfur compounds.**

Unions in gas lines should be of ground joint type.

The gas supply line must be sized and installed to provide a supply of gas sufficient to meet the maximum demand of the appliance without undue loss of pressure.

Sealant used must be resistant to the action of all gas constituents including propane gas. Sealant should be applied lightly to male threads to ensure excess sealant does not enter gas lines.

The supply line should include a *manual shut-off valve* to allow the appliance to be disconnected for servicing.

A plugged 1/8 inch NPT tapping must be installed in the line. The tapping must be accessible for test gauge connection and be immediately upstream of the gas supply connection to the appliance.

### Pressure test the supply line for leaks.

- The appliance and its individual shut-off valve must be disconnected from the gas supply piping system during any pressure testing of that system at test pressures in excess of 1/2 psig (3.5kPa).
- The appliance must be isolated from the gas supply piping system by closing its individual manual shut-off valve during any pressure testing of the gas supply piping system at test pressures equal to or less than 1/2 psig (3.5kPa).

- Failure to either disconnect or isolate the appliance during pressure testing may result in regulator or valve damage. Consult your dealer in this case.

The minimum supply pressure is given in the *Specifications* section of this manual.

All piping and connections must be tested for leaks after installation or servicing. All leaks must be corrected immediately.

When testing for leaks:

- Make sure that the appliance is turned off.
- Open the manual shut-off valve.
- Test for leaks by applying a liquid detergent or soap solution to all joints. Bubbles forming indicate a gas leak. **Never use an open flame to check for leaks.**
- Correct any leak detected immediately.

The pressure test tapping locations are shown below. A built-in non-adjustable regulator controls the burner manifold pressure. The correct pressure range is shown in the table in *Specifications* section of this manual. The pressure check should be made with the burner alight and at its highest setting. See *Lighting Instructions* section for full operating details.

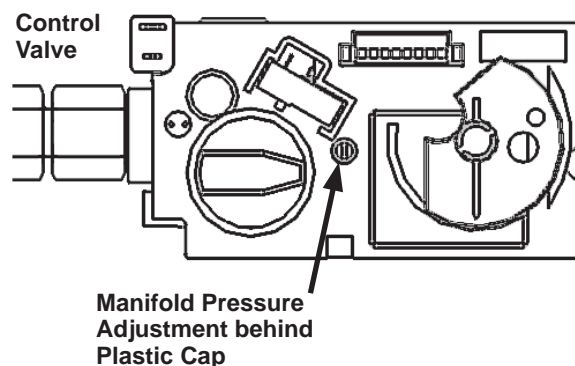
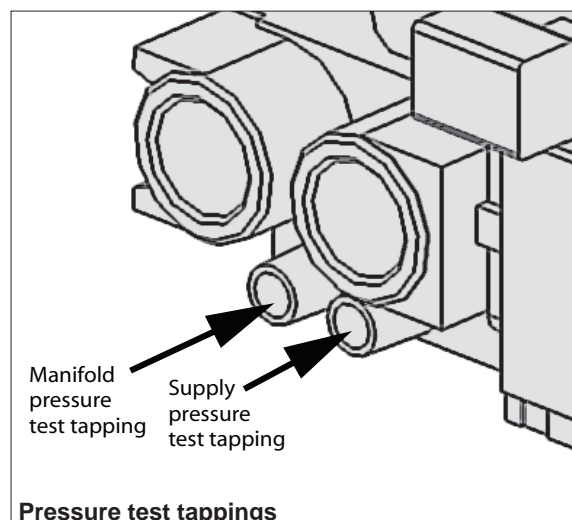

## Installation

### Install Liner Panels

All liner panels can be installed as indicated below **except** the 618RGL—Reflective Glass Liners—see instructions packed with the liners.

Unpack the liners carefully to avoid scratching or damaging them.

1. Place the rear panel against the back of the firebox on the ledge of the rear log support. Make sure the bevel part is at the top.

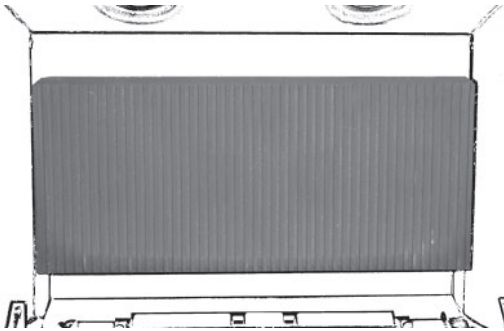

2. Hold the left hand side panel at an angle and insert its bottom edge inside the firebox. Rotate the panel to a vertical position ensuring that the top edge is behind the flange of the firebox. Pull the panel as forward as possible against the left edge of the firebox.

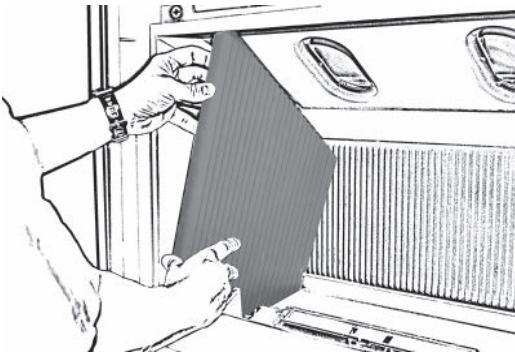

3. Hold the right hand side panel at an angle and insert its bottom edge inside the firebox. Rotate the panel to a vertical position ensuring that the top edge is behind the flange of the firebox. Pull the panel as forward as possible against the right edge of the firebox.

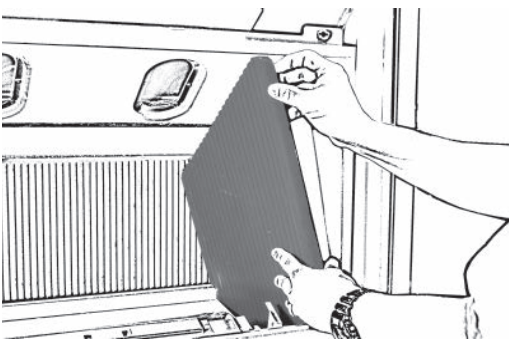

4. Insert the top panel over the left side panel while holding the top panel forward up the slope. Rotate the right side of the top panel upwards and place it over the top of the right panel. Slide the top panel down the slope of the firebox as far as possible to close the gap with the rear panel and to maximize the gap above the front edge of the top panel.

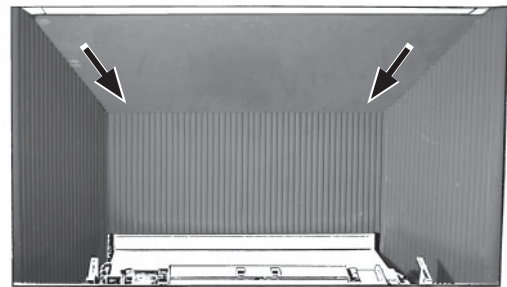
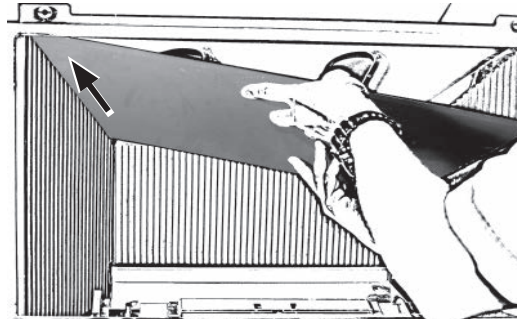



## Installation

### Install 534LSK Traditional Logs

Unpack the ceramic logs very carefully to avoid damaging their fragile material. Install the logs as shown below. **Please note that the position of the logs is critical to insure the good performance of the appliance.**

1. Place the rear log on the sheet metal support centering it side to side in the firebox. Pull it forward until the notch in the underside of the log sits against front edge of the sheet metal support.

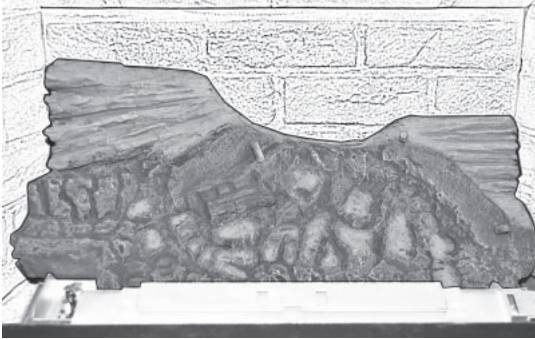

2. Place the top left log on the pin of the rear log. The bottom of the log rests against the left of the pilot shield and slightly above.

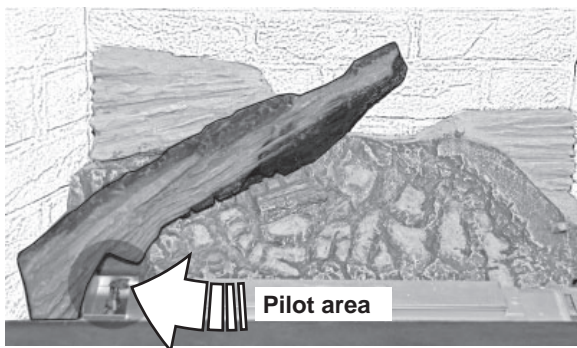

3. Place the front left log on the burner. Slide it to the left against the top left log. The narrow end should rest in the notch in the rear log.

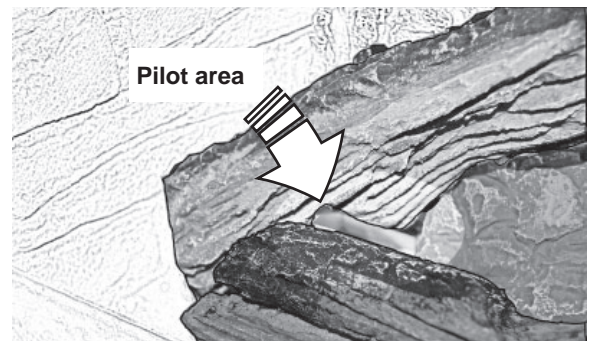
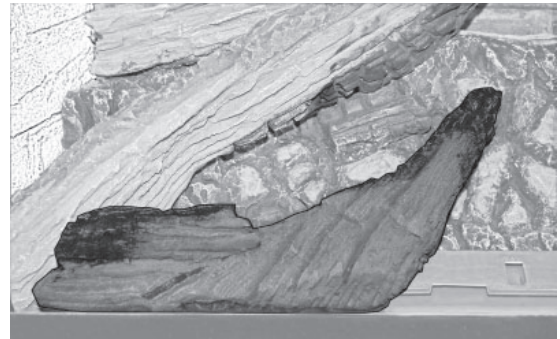

4. Place the front right log on the burner and slide it to the left against the front left log.

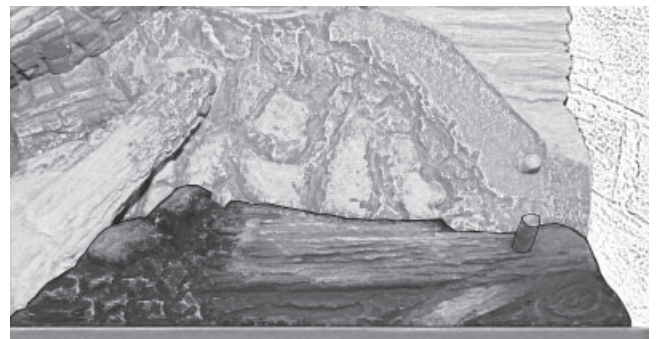

5. Locate the top right log on the two pins on the right side of the rear log. Ensure a tight fit against the flat area around the pins in the rear log.

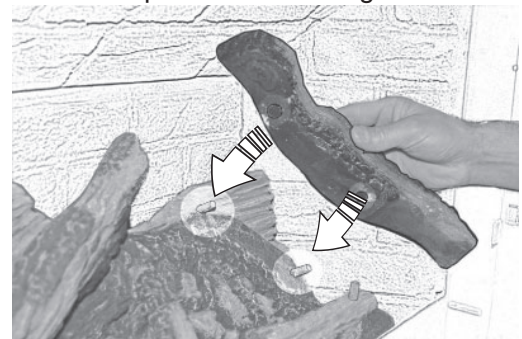

6. Place the lower end of the center right log onto the pin on the front right log. Rest the narrow end in the notch into the rear log.

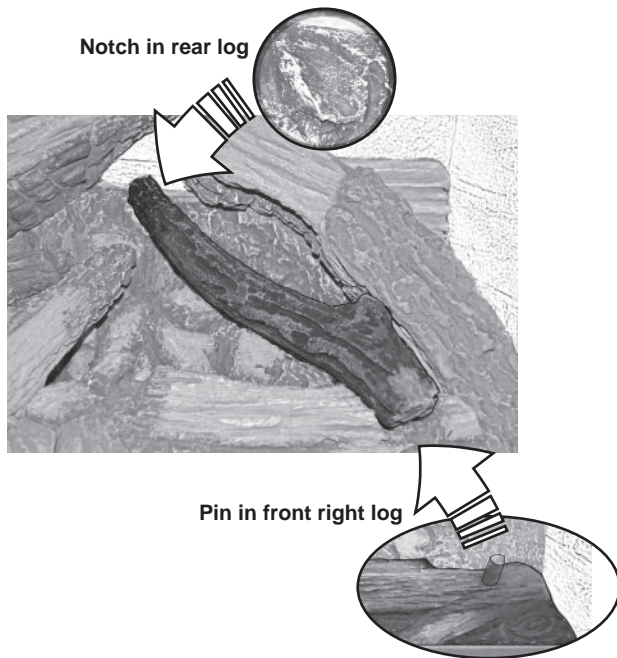

7. Pour some ceramic loose coals on each side of the logs to hide the sheet metal work. **Do NOT put any coal into the pilot area.**





## Install 534RSK Ceramic Rocks

Unpack the ceramic rocks kit very carefully to avoid damaging the fragile material. Install the components as shown below. Please note that **the position of the rocks and twigs (if used) is critical to ensure proper performance of the appliance.**

1. Install the Front Support Platform in the firebox carefully sliding it down between the burner and the front bottom edge for the firebox while avoiding scraping the side ceramic panels.

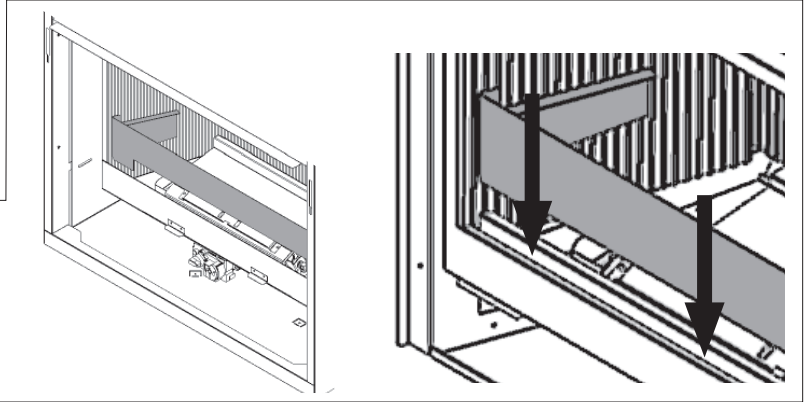
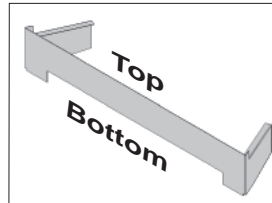

2. Place the rock ceramic base on the log support behind the burner. The front bottom of the base must rest against the front lip of the log support.

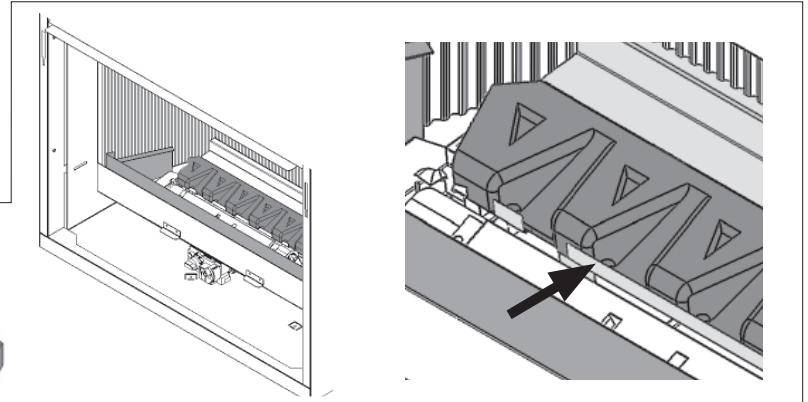
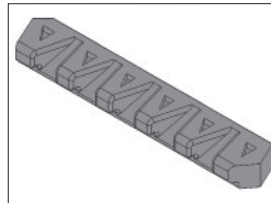

3. Install the ceramic platform in the firebox rotating down to insert the front first behind the Front Support. Lay the back of the ceramic platform against the rear ceramic panel again being careful not to scrape the ceramic panels.

**Warning: This platform is quite fragile. DO NOT force it in place.**

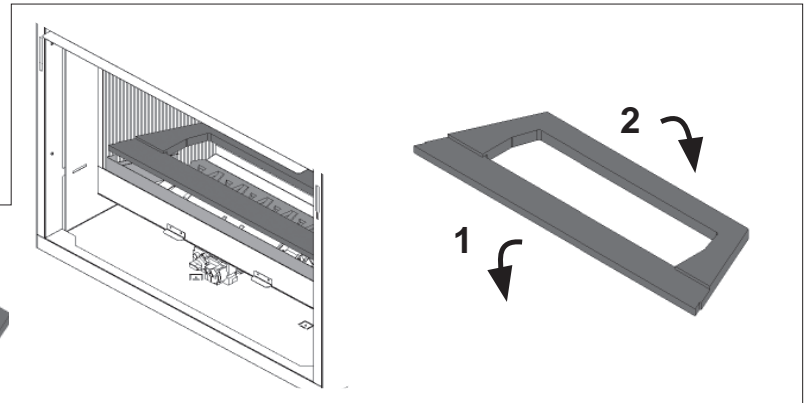
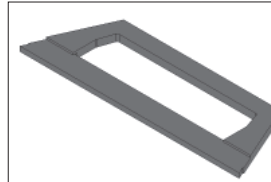

**Fuel Bed Base  
Installed**

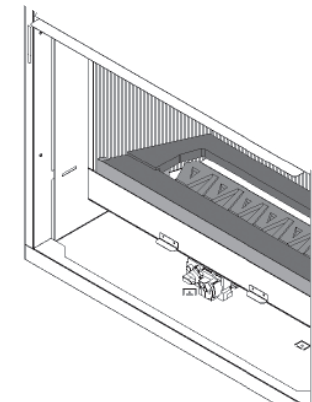

## Installation

4. The underside of each ceramic rock is identified by a number and a specific protruding positioning triangle.

Install the six rocks from left to right starting with rock no. 1.

Note: The ceramic base may need to be slightly adjusted side-to-side to allow stones to fit within the platform.

A black discoloration may form over time at the front bottom of the 6-rock original fuel bed; this deposit can be burned off by running the fireplace on a low to medium setting fire for 30 to 45 minutes. This discoloration is unavoidable and will re-form again.

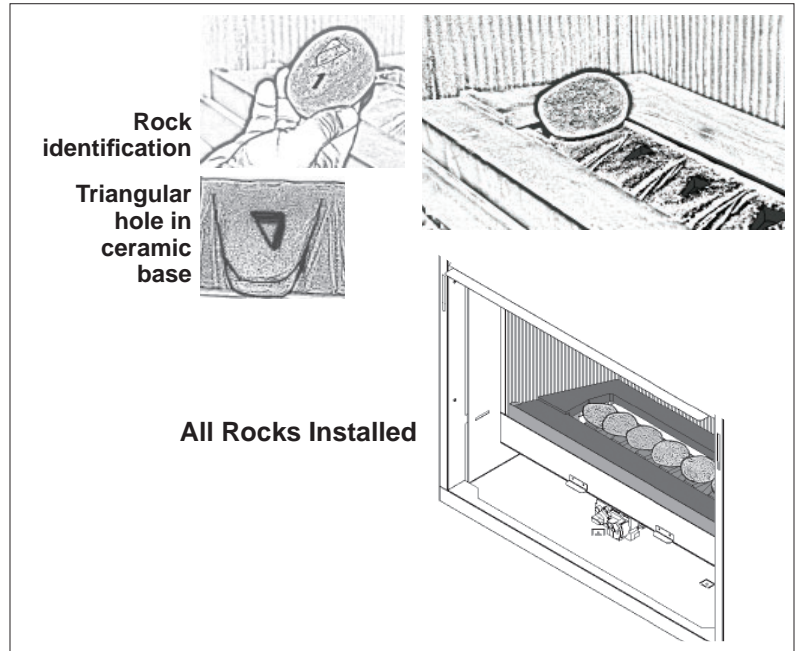

5. Place the glass panel in its cavity formed by the Front Support and the Ceramic Platform.

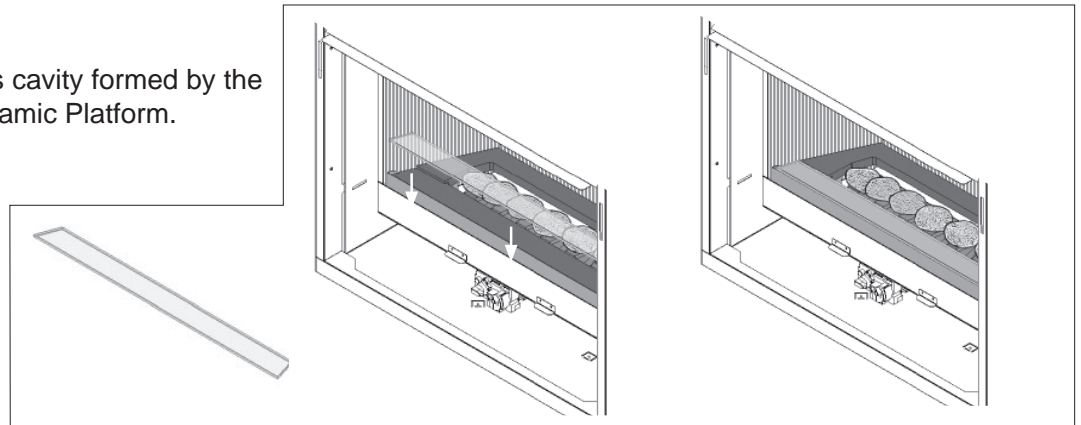

6. Place the left twig across the second and third rocks from the **left**; rest its end on the glass near the edge of the platform as shown. **Make sure to leave a gap between the twig and the first rock to allow flame to come up between the twig and the rock.**

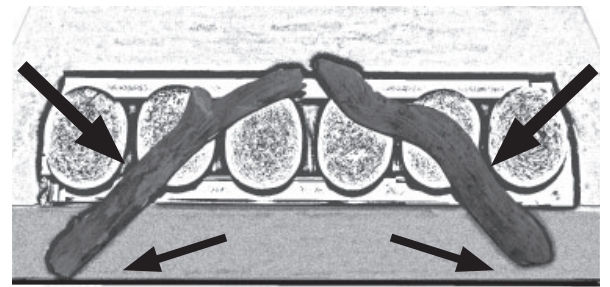

7. Place the right twig across the second and third rocks from the **right**; rest its end on the glass about 1 cm from the edge of the platform as shown. **Make sure to leave a gap between the twig and the first rock to allow flame to come up between the twig and the rock.**

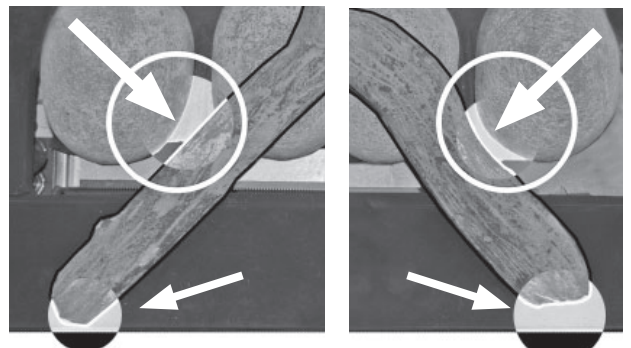

## Install 534DWK Driftwood Kit

Unpack the driftwood kit very carefully to avoid damaging the fragile material. Install the components as shown below. Please note that **the position of the logs and pebbles (if used) is critical to ensure proper performance of the appliance.**

### Platform

Place the platform into the firebox on top of the burner.

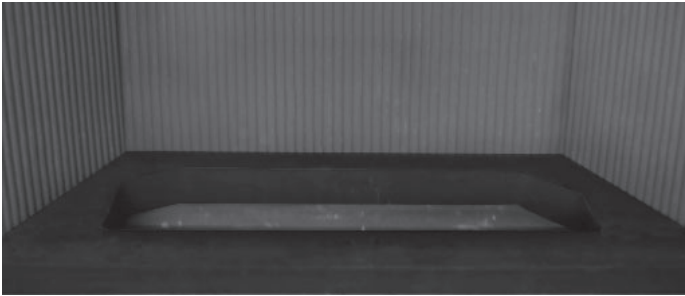

### Logs

1. Identify the base log and place it in the cavity of the ceramic platform. The protruding parts of the log in the front should rest against the lip of the sheet metal log support behind the burner.

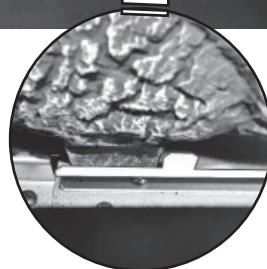
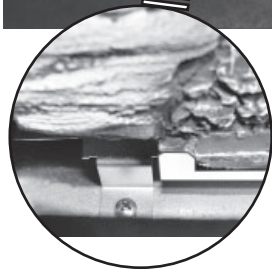
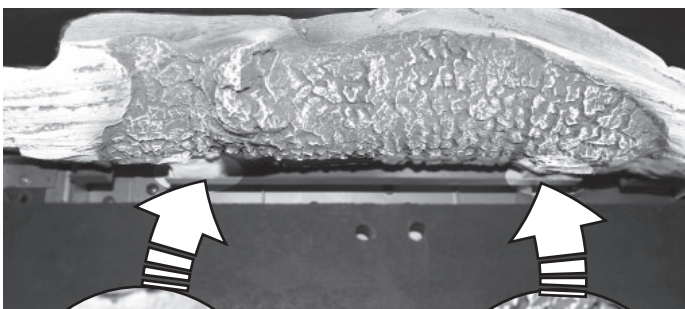

2. Identify the rear log and place it on top of the base log locating it into the notches on top of the log. Pull the log forward so it is locked in position.



3. Place the front log inserting its two pins into the two holes at the front of the platform. The ends of the log should be oriented towards the front as the log should not hang over the inside edge of the platform.

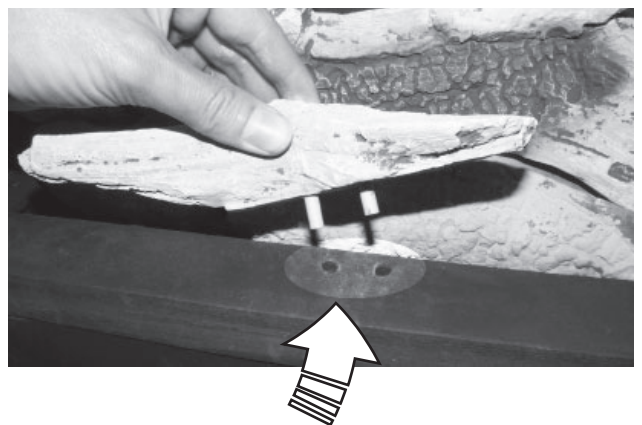



## Installation

4. Identify the right side cross log, the longest, and place it across the rear log. The narrow end of the log rests in a notch of the rear log. The wide end of the log lays flat on the platform, flush with the edge as indicated.

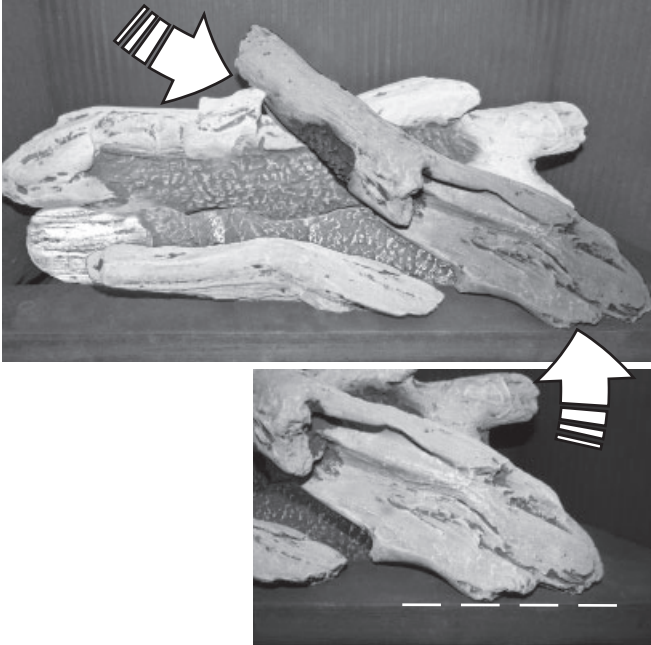

### Pebbles

Six pebbles are supplied as decorative elements. If used, they should be placed on the platform only. We suggest to place the larger ones to cover the inside edge corners of the platform and place others randomly. Not all of them have to be used.



5. Identify the left side cross log which has one pin at one end. Insert the pin in the hole at the front left of the platform and rests the top part of the log into the notch of the rear log as indicated.



## Refit and Check Window

1. Refit the window with the bottom two bolts. The bolts should be screwed in securely.
2. Refit the top two bolts securing by turning them through 90 degrees.
3. Pull the top of the window forward and release to check that it opens slightly and returns confirming the good function of the spring-loaded mechanism.
4. Similarly check the bottom of the window by pulling it forward and releasing.

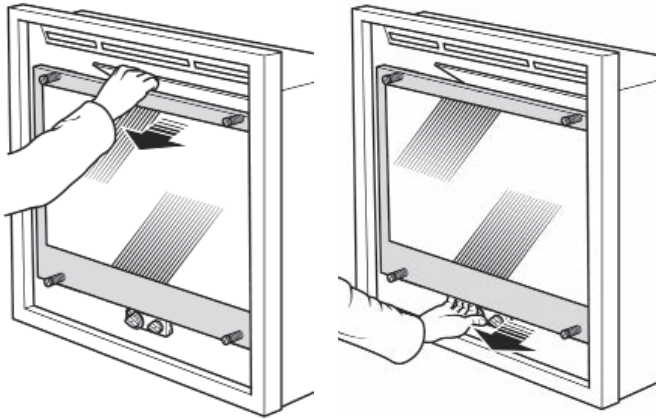

5. Apply firm hand pressure around the window frame to ensure the window is sealed tight against the firebox.

6. If the Hot Glass Warning plate has been removed from the front lower corner of the window, reinstall it by sliding it between the glass and the frame as indicated.

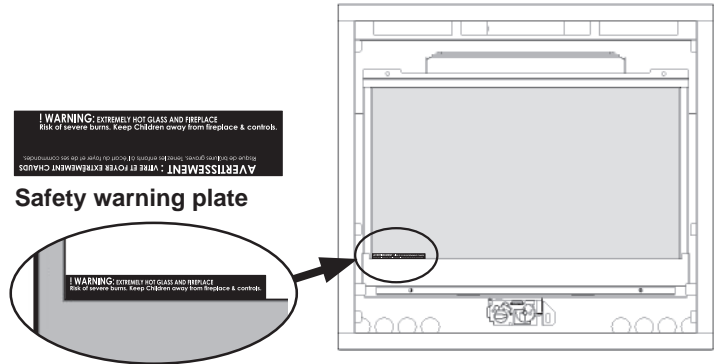

**⚠ DANGER**

The window unit must be correctly installed, fastened and sealed after servicing or serious bodily injury and/or damage to the appliance may result.

To ensure a safe operation:

- Double-check that the window frame is correctly installed;
- Verify that the bolts and spring-loaded bolts are hooked properly to the window tabs then;
- Pull out the top of the window and release it to insure the springs return it;
- Ensure the window is sealed before operation.

**⚠ WARNING**

Failure to install the window correctly can leak carbon monoxide, affect the performance of the fireplace, damage components, cause overheating resulting in dangerous conditions. Damage caused by incorrect window installation is not covered by the Valor warranty.



## Installation

### Install Battery Holder

The batteries that power the receiver and handset need to be installed prior to synchronization and use.

1. Take the receiver out from under the firebox.
2. The battery holder and cable are supplied with the appliance. Insert 4 x 1.5 V high quality alkaline batteries in the battery holder and 1 9V battery in the remote handset.



3. Connect the cable to the receiver.

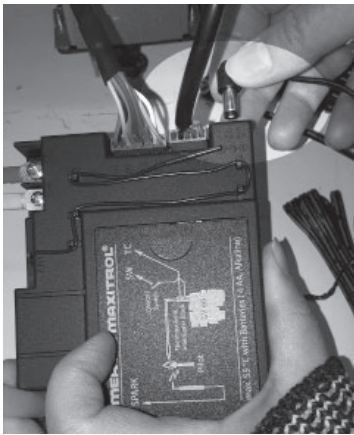

4. Connect the other end of the cable to the battery holder.

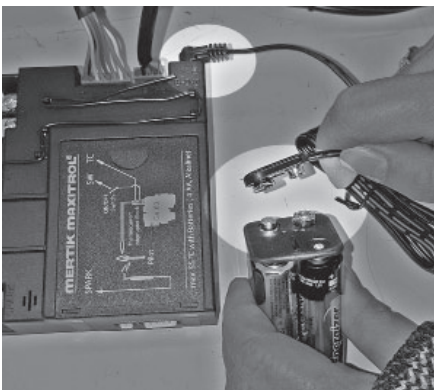

5. Place the receiver and battery holder as shown below (placement may vary with installed options).

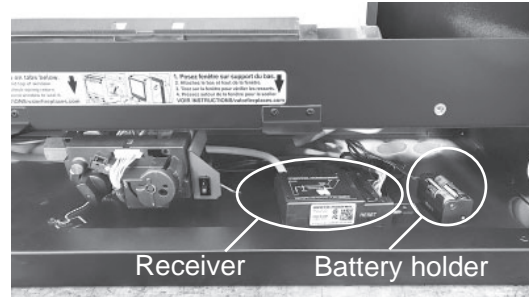

6. Use a heat resistant tie to gather any extra cable between the receiver and the holder.

### CAUTION

**DO NOT** let the cable touch the burner plate above, it will melt during operation.

### Synchronize Remote Control

The receiver and the handset of the remote control system must be initially synchronized before the first use.

1. With a thin object, press and hold the receiver's reset button until you hear one short and one long beep. Release the button after the second beep.

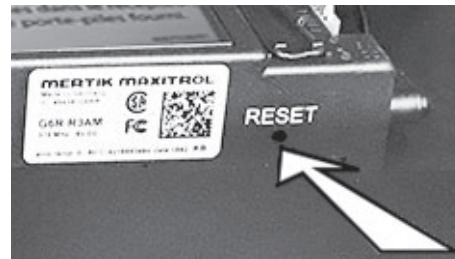

2. Within the subsequent 20 seconds, press the small flame button (🔥) on the remote handset until you hear two short beeps confirming the synchronization is set.

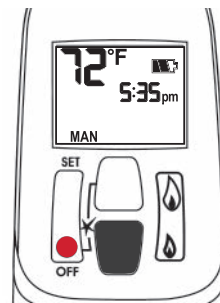

This is a one time setting only and is not required when changing the batteries in the remote handset. The remote control system is now ready to use.

# Installation

## Check Operation

Turn the fireplace flame up and down using the remote control to confirm that the full range of inputs is achieved—see the remote control operation instructions starting on page 8.

## Adjust Aeration (if needed)

Light the fire and allow the unit to warm up for 10–15 minutes to evaluate the flame picture. Burners are equipped with an adjustable shutter to control primary aeration. See the figures below. The shutter is factory-set to an aeration gap which will give optimum performance for the vast majority of installations.

### Air Shutter

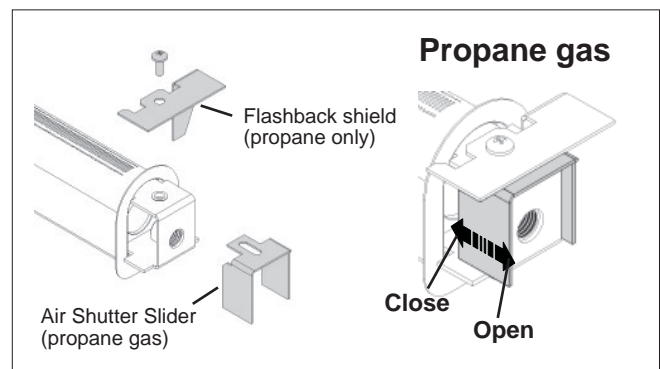
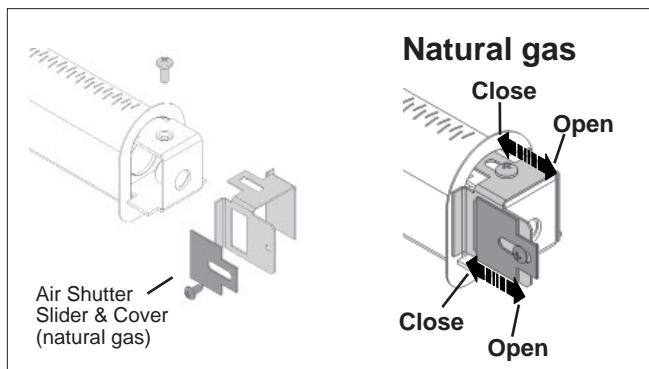

In some installations, depending of the fuel bed used, the altitude and other considerations, the flame picture may be improved by adjusting the aeration. The need for adjustment should be determined only by operating the appliance with the fuel bed and window installed and evaluating the flame picture after a 15-minute warm-up.

**Increasing aeration** will cause the flames to appear more transparent and blue showing more ceramic effects glow.

**Decreasing aeration** will cause the flames to appear more yellow or orange showing less ceramic effects glow.

**Too little aeration may result in black carbon forming and dropping into the firebox.**

## Install Front, Trim and Barrier Screen

Install the front or trim chosen by the customer for their fireplace. Install as well the barrier screen which is provided with the front or trim.

Show the customer how to access the controls when the front or trim are installed and how to remove them.

Follow the instructions provided with the front or trim and leave those instructions behind for the customer's further reference.

## Install Handset Wall Holder

The remote control kit for this fireplace comes complete with a wall-mounted holder. This holder is not required in all installations but is provided as an optional feature for those customers who wish to mount the remote handset to the wall.

To install the holder to the wall, find a convenient location and use the hardware provided with the kit. See the diagram on the right for required hardware and configurations. Note that the holder can be installed at the base of a light switch plate.

**IMPORTANT.** The location of the remote control handset is important to assure proper temperature regulation. To obtain a constant temperature, we recommend that the handset should be between 3 and 15 feet away from the appliance **but not directly above it**. We also advise that the handset should be located away from any other heat source and not in direct sunlight as this may affect the temperature sensor located in the remote handset.

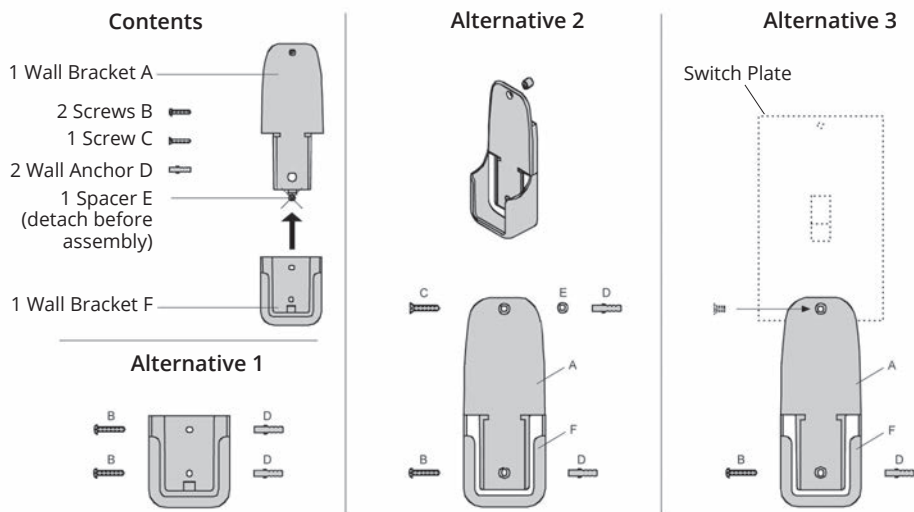

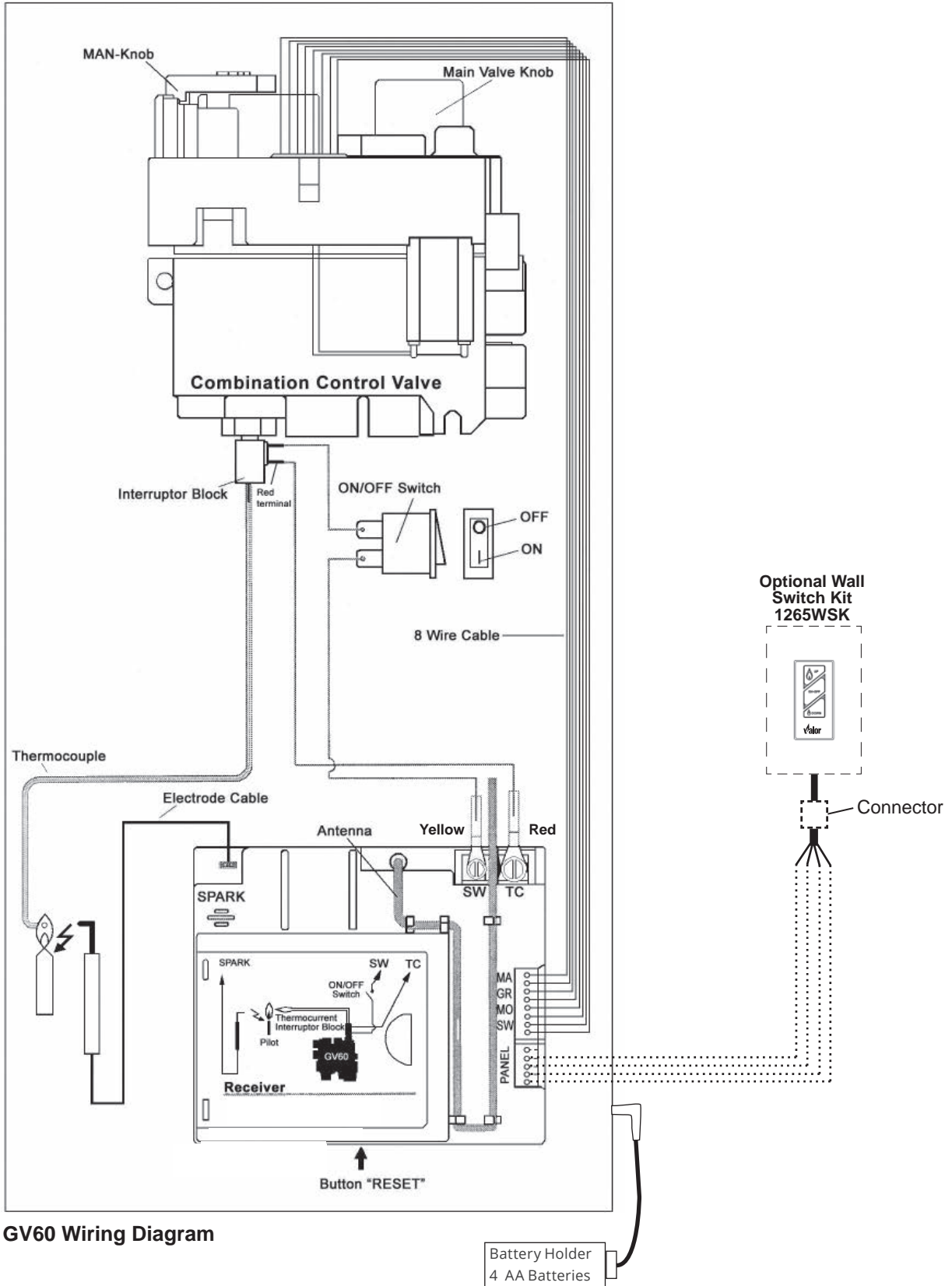

# Wiring Diagram

**QUALIFIED  
INSTALLER**



**GV60 Wiring Diagram**

## Approved Venting Components

<b>Approved Direct Vent Suppliers for Valor Models 530<sup>6</sup>, 534, 650 and MF28<sup>7</sup></b>										
 		<b>Venting Parts Code / availability by Manufacturer</b>								
		DURA-VENT	SELKIRK	ICC EXCEL DIRECT	SECURE VENT	RLH INDUSTRIES	AMERIVENT	MILES INDUSTRIES	BDM	
<b>Venting Parts Description</b>										
<b>Termination Caps</b>	<b>Horizontal</b>	Standard Co-axial	46DVA-HC	4DT-HC	TM-4HT	—	—	4DHC round	658DVK2	940160
		Deluxe Co-axial	—	—	TM-4RHT	—	—	4DHCS square	—	940160
		High Wind Co-axial	—	—	—	SV4CHC	—	—	—	—
	<b>Vertical</b>	Standard Co-axial	46DVA-VC	4DT-VT	—	—	HSDV4658-1313	4DVC	—	940264
						4DH-1313		940364		
						—		940206LP		
		High Wind Co-axial	46DVA-VCH	—	TM-4SVT	SV4CGV	—	—	—	—
		Extended Co-axial	46DVA-VCE	—	—	—	—	—	—	—
		Co-linear	—	—	TM-IVT	3PDVCV	HS-C33U-99	HCL-99-33	559CLT	940033B
							HS-C33F-1313	HCL-913-33		940034B
						HCL-1313-33	720SWK <sup>6</sup>	940033HWS		
								940033RD		
Snorkel, 14" Rise	46DVA-SNK14	4DT-ST14	TM-4ST14	—	—	—	4D14S	—	94040614	
Snorkel, 36" Rise	46DVA-SNK36	4DT-ST36	TM-4ST36	—	—	—	4D36S	—	94040636	
<b>Vent Adapters / Couplers</b>	Universal Adapter 3" Flex Coupler	2150	—	TM-CFAA3	—	—	—	—	95090390	
	Valor Adapter	817VAK	—	TM-4AA2	—	—	4DSC-V	—	—	
	Co-linear Flex Connector	46DVA-ADF	—	—	—	—	—	—	—	
	Co-axial-to-Co-linear Adapter	46DVA-GCL 46DVA-CLAA	—	TM-4CAA	—	—	4DCAB33	556CLA	940106433	
	Co-linear-to-Co-axial Adapter	46DVA-GK 46DVA-CLTA	—	TM-4CTA	—	—	4DCAT33	—	—	
	DV to B-Vent Adapter	—	—	—	—	—	—	DVA5BV <sup>7</sup>	—	
<b>Aluminum Flexible Liner</b>	3" or 4" diameter	NOTE: 2-ply liner approved to CAN/ULC S635 suitable for venting gas appliances. As manufactured by Z-Flex, Flexmasters or others.								
		2280 Series	AF3-35L	TM-ALK33	—	—	—	—	952703	
				TM-ALT33	—	—	—	952704		
<b>Adjustable Pipe Length and Pipe Extensions 4" x 6-5/8"</b>	Galvanized or Black	46DVA-08A 46DVA-08AB (3" to 7")	4DT-ADJ	—	—	—	4D7A or 4D7AB (3" to 5")	—	94610608 (4" to 8-1/2")	
			4DT-ADJ(B)	—	—	—	—	—		
	Galvanized or Black	46DVA-16A 46DVA-16AB (3" to 14-1/2")	—	—	TC-4DLS1	SV4LA	—	4D12A or 4D12AB (3" to 10")	94610616 (4" to 16")	
			—	—	TC-4DLS1B	SV4LBA	—	—	—	
	Galvanized or Black	46DVA-17TA 46DVA-17TAB (11" to 17")	—	—	TC-4DLS2	SV4LA12	—	4D16A or 4D16AB (3" to 14")	—	
			—	—	TC-4DLS2B (1-7/8" – 21")	SV4LBA12	—	—	—	
Galvanized or Black	46DVA-24TA 46DVA-24TAB (17" to 24")	—	—	TC-4DLA30	SV4LA24	—	4D26A or 4D26AB (3" to 24")	—		
		—	—	TC-DLA30B (16.5" – 29")	SV4LBA24	—	—	—		
Co-axial Flex	46DVA-48FF 46DVA-120FF	—	—	—	—	—	—	—		
<b>DV 45° Elbows</b>	Galvanized	46DVA-E45	—	TE-4DE45	—	—	4D45L	—	94620645	
	Black	46DVA-E45B	—	TE-4DE45B	SV4EBR45	—	4D45LB	—	94620645B	
	Galvanized Swivel	—	4DT-EL45	—	SV4E45	—	—	—	—	
	Black Swivel	—	4DT-EL45(B)	—	SV4EB45	—	—	—	—	
<b>DV 90° Elbows</b>	Galvanized	46DVA-E90	—	TE-4DE90	—	—	4D90L	—	—	
	Black	46DAV-E90B	—	TE-4DE90B	SV4EBR90	—	4D90LB	—	—	
	Galvanized Swivel	—	4DT-EL90	—	SV4E90	—	—	—	94620690	
	Black Swivel	—	4DT-EL90(B)	—	SV4EB90	—	—	—	94620690B	



# Approved Venting Components

**QUALIFIED  
INSTALLER**

Venting Parts Description			Venting Parts Code / availability by Manufacturer							
			DURA-VENT	SELKIRK	ICC EXCEL DIRECT	SECURE VENT	RLH INDUSTRIES	AMERIVENT	MILES INDUSTRIES	BDM
Pipes 4" x 6 5/8" ( ID x OD )	6" long	Galvanized	46DVA-06	4DT-06	TC-4DL6	SV4L6	—	—	—	94610606
		Black	46DVA-06B	4DT-06(B)	TC-4DL6B	SV4LB6	—	—	—	90410606B
	7" long	Galvanized	—	—	—	—	—	4D7	—	—
		Black	—	—	—	—	—	4D7B	—	—
	9" long	Galvanized	46DVA-09	4DT-09	TC-4DL9	—	—	—	—	94610609
		Black	46DVA-09B	4DT-09(B)	TC-4DL9B	—	—	—	—	94610609B
	12" long	Galvanized	46DVA-12	4DT-12	TC-4DL1	SV4L12	—	4D12	—	94610612
		Black	46DVA-12B	4DT-12(B)	TC-4DL1B	SV4LB12	—	4D12B	—	94610612B
	18" long	Galvanized	46DVA-18	4DT-18	—	—	—	—	—	94610618
		Black	46DVA-18B	4DT-18(B)	—	—	—	—	—	94610618B
	24" long	Galvanized	46DVA-24	4DT-24	TC-4DL2	SV4L24	—	4D2	—	94610624
		Black	46DVA-24B	4DT-24(B)	TC-4DL2B	SV4LB24	—	4D2B	—	94610624B
	36" long	Galvanized	46DVA-36	4DT-36	TC-4DL3	SV4L36	—	4D3	—	94610636
		Black	46DVA-36B	4DT-36(B)	TC-4DL3B	SV4LB36	—	4D3B	—	94610636B
	48" long	Galvanized	46DVA-48	4DT-48	TC-4DL4	SV4L48	—	4D4	—	94610648
		Black	46DVA-48B	4DT-48(B)	TC-4DL4B	SV4LB48	—	4D4B	—	94610648B
Flashings	Roof Flashing 0/12-6/12		46DVA-F6	4DT-AF6	TF-4FA	SV4FA	—	4DF (0/12-5/12)	—	949606012
	Roof Flashing 7/12-12/12		46DVA-F12	4DT-AF12	TF-4FB	SV4B	—	4DF12 (6/12-12/12)	—	949606712
	Flat Roof Flashing		46DVA-FF	—	TF-4F	SV4F	—	—	—	949606001
	Masonry Flashing		—	—	TF-4MF	—	—	—	559FSK	—
	New Siding Flashing		—	—	—	—	—	—	658NSFK	—
Various Venting System Parts	Wall Thimble		46DVA-WT	4DT-WT	TM-4WT	SV4RSM	—	4DWT	—	949064U
	Storm Collar		46DVA-SC	4DT-SC	TM-SC	SV4AC	—	4DSC	—	94960608
	Decorative Plate		46DVA-DC	4DT-CS	TM-4TR TM-4TP	SV4PF	—	4DFPB	—	94940612
	Cathedral Ceiling Support		46DVA-CS	4DT-CCS	TM-4SS	—	—	4DRSB	—	949506KT
	Ceiling Firestop / Floor Support		46DVA-FS	4DT-FS	TM-4RDS	SV4BF	—	4DFSP	—	94980612
					TM-CS	SV4SD				
	Attic Radiation Shield / Firestop		—	—	TM-4AS	—	—	4DAIS12 (12")	—	94930620A
								4DAIS36 (36")		
	Wall Strap		46DVA-WS	4DTWS	TM-WS	—	—	4DWS	—	949164
	Vinyl Siding Standoff		46DVA-VSS	4DT-VS	TM-VSS	SV4VS	—	4DHVS	—	94800615S
Elbow Strap / Offset Support		46DVA-ES	4DT-OS	TM-OS	—	—	—	—	949264	
Terminal Guard		46DVA-WG	—	TM-HTS	—	—	—	845TG	940164SHRD	
				TM-RHTS				658TG		

- Notes:**
1. All listed above co-axial pipes and fittings require Valor 817VAK Adapter Kit to fit Valor's smooth collars (Valor adapter 4DSC-V by American Metal Products may also be used).
  2. Follow instructions supplied with each manufacturer's components.
  3. Unless otherwise specified, all the parts and assemblies from the above table are to be used with 4" x 6-5/8" pipes.
  4. Do not mix components from different vent manufacturers.
  5. Termination caps manufactured by RLH Industries or American Metal Products are from Homestyle Chimney Collection and can be ordered in one of the following finishes: a) aluminium; b) black powder coated; c) solid copper.
  6. The 720SWK Sidewall Co-Linear Kit can only be installed on the 530 models (CANNOT be used with coal effect models).
  7. The DVA5BV DV to BV adapter CANNOT be installed on the MF28 models.

**State of Massachusetts Carbon Monoxide  
Detector/Vent Terminal Signage  
Requirements**

For all side wall horizontally vented gas fueled equipment installed in every dwelling, building or structure used in whole or in part for residential purposes, including those owned or operated by the Commonwealth and where the side wall exhaust vent termination is less than seven (7) feet above finished grade in the area of the venting, including but not limited to decks and porches, the following requirements shall be satisfied:

**1. INSTALLATION OF CARBON MONOXIDE DETECTORS.** At the time of installation of the side wall horizontal vented gas fueled equipment, the installing plumber or gas fitter shall observe that a hard wired carbon monoxide detector with an alarm and battery back-up is installed on the floor level where the gas equipment is to be installed. In addition, the installing plumber or gas fitter shall observe that a battery operated or hard wired carbon monoxide detector with an alarm is installed on each additional level of the dwelling, building or structure served by the side wall horizontal vented gas fueled equipment. It shall be the responsibility of the property owner to secure the services of qualified licensed professionals for the installation of hard wired carbon monoxide detectors.

a. In the event that the side wall horizontally vented gas fueled equipment is installed in a crawl space or an attic, the hard wired carbon monoxide detector with alarm and battery back-up may be installed on the next adjacent floor level.

b. In the event that the requirements of this subdivision can not be met at the time of completion of installation, the owner shall have a period of thirty (30) days to comply with the above requirements; provided, however, that during said thirty (30) day period, a battery operated carbon monoxide detector with an alarm shall be installed.

**2. APPROVED CARBON MONOXIDE DETECTORS.** Each carbon monoxide detector as required in accordance with the above provisions shall comply with NFPA 720 and be ANSI/UL 2034 listed and IAS certified.

**3. SIGNAGE.** A metal or plastic identification plate shall be permanently mounted to the exterior of the building at a minimum height of eight (8) feet above grade directly in line with the exhaust vent terminal for the horizontally vented gas fueled heating appliance or equipment. The sign shall read, in print size no less than one-half (1/2) inch in size, "GAS VENT DIRECTLY BELOW. KEEP CLEAR OF ALL OBSTRUCTIONS".

**4. INSPECTION.** The state or local gas inspector of the side wall horizontally vented gas fueled equipment shall not approve the installation unless, upon inspection, the inspector observes carbon monoxide detectors and signage installed in accordance with the provisions of 248 CMR 5.08(2)(a)1 through 4.

(b) **EXEMPTIONS:** The following equipment is exempt from 248 CMR 5.08(2)(a)1 through 4:

1. The equipment listed in Chapter 10 entitled "Equipment Not Required To Be Vented" in the most current edition of NFPA 54 as adopted by the Board; and
2. Product Approved side wall horizontally vented gas fueled equipment installed in a room or structure separate from the dwelling, building or structure used in whole or in part for residential purposes.

(c) **MANUFACTURER REQUIREMENTS - GAS EQUIPMENT VENTING SYSTEM PROVIDED.** When the manufacturer of Product Approved side wall horizontally vented gas equipment provides a venting system design or venting system components with the equipment, the instructions provided by the manufacturer for installation of the equipment and the venting system shall include:

1. Detailed instructions for the installation of the venting system design or the venting system components; and
2. A complete parts list for the venting system design or venting system.

(d) MANUFACTURER REQUIREMENTS - GAS  
EQUIPMENT VENTING SYSTEM NOT PROVIDED.

When the manufacturer of a Product Approved side wall horizontally vented gas fueled equipment does not provide the parts for venting the flue gases, but identifies “special venting systems”, the following requirements shall be satisfied by the manufacturer:

1. The referenced “special venting system” instructions shall be included with the appliance or equipment installation instructions; and
2. The “special venting systems” shall be Product Approved by the Board, and the instructions for that system shall include a parts list and detailed installation instructions.

(e) A copy of all installation instructions for all Product Approved side wall horizontally vented gas fueled equipment, all venting instructions, all parts lists for venting instructions, and/or all venting design instructions shall remain with the appliance or equipment at the completion of the installation.

**THIS WARRANTY DOES NOT APPLY TO OUTDOOR INSTALLATIONS—SEE WARRANTY SUPPLIED WITH GV60CKO OUTDOOR KIT.**

If you have a problem with this unit, please contact your dealer or supplier immediately. Under no circumstances should you attempt to service the unit in any way by yourself. The warranties in paragraphs 1 and 2 are provided only to the initial user of this unit, are not transferable and are subject to the conditions and limitations in paragraphs 3, 4 and 5. Please review the conditions and limitations carefully and strictly follow their requirements.

**1. Extended Warranty Coverage**

For a period of up to ten (10) years, Miles Industries Ltd., (the “Company”) or its appointed distributor will at its option pay the initial owner for the repair of, or will exchange the following parts or components which are found to be defective in material or workmanship under normal conditions of use and service:

Maximum Warranty Period		10 years
Part or Component	Defect Covered	
Exterior steel casing	Corrosion	✓
Glass	Loss of structural integrity	✓
Cast iron parts	Corrosion	✓
Firebox and heat exchanger	Corrosion (but not discoloration) causing loss of structural integrity	✓

**2. Two-Year Parts Warranty**

In addition, for two (2) years from the date of purchase, the Company, at its option, will repair or exchange all parts and components not listed above but that are found to have a bona fide defect in material or workmanship under normal conditions of use.

**3. Conditions and Limitations**

- a) The warranty registration card must be completed by the initial owner and returned to the company within 90 days. Alternatively, the warranty registration form may be filled out online at [www.valorfireplaces.com](http://www.valorfireplaces.com)
- b) Installation and maintenance must be performed by an authorized and trained dealer in accordance with the Company’s installation instructions.
- c) This warranty is void where installation of the unit does not conform to all applicable codes including national and local gas appliance installation codes and building and fire codes.
- d) The owner must comply with all operating instructions.
- e) The Company is not responsible for the labor costs to remove defective parts or re-install repaired or replacement parts.
- f) The initial owner of the unit will be responsible for any shipping charges for replacement parts as well as travel time incurred by the dealer to perform the warranty work.

- g) This warranty applies to non-commercial use and service and is void if it is apparent that there is abuse, misuse, alteration, improper installation, accident or lack of maintenance to the unit.
- h) The warranty does not cover damage to the unit through:
  - i) Improper installation, operational or environmental conditions.
  - ii) Inadequate ventilation in the area or competition for air from other household equipment or appliances.
  - iii) Chemicals, dampness, condensation, or sulphur in the fuel supply lines which exceeds industry standards.
- i) This warranty does not cover glass, log breakage or damage to the unit while in transit.
- j) The Company does not allow anyone to extend, alter or modify this warranty and assumes no responsibility for direct, indirect or consequential damages caused by the unit. State or provincial laws where the initial user or user resides may provide specific rights extending this warranty and, if so, the Company’s sole obligation under this warranty is to provide labor and/ or materials in accordance with those laws.

**4. Discharge of Liability**

After two (2) years from the date of purchase, the Company may, at its option, fully discharge all obligations under this warranty by paying to the first owner the wholesale price of, or replacing, any defective parts.

**5. No Other Warranty**

All obligations to repair this unit are defined in this warranty. Some states or provinces may specifically mandate additional obligations on the part of manufacturers, but in the absence of such specific legislation, there is no other warranty or obligation expressed or implied.



# Replacement Parts

	Description	Part no.
1	Top stand-offs (2)	3000192
2	Top heat shield panel	350A008
3	Top frame support angle bracket	3000181
4	Outer vent collar	330A888
5	Blanking plate	330A964
6	Side frame fixing brackets (2)	3000255
7	Side stand-offs brackets (2)	320B423
8	Convection heat baffle	340B308AZ
9	Support for rear log and rocks	4001999
10	Burner module (natural gas)	4001952
	Burner module (propane gas)	4001953
11	Window assembly	3000389S
11a	Window screw assembly (2)	000B214S
12	Restrictor plates (2)	4002895
13	Adjustable plates (2)	4002896
	Screws (2) (not shown)	100A757
15a	Flashback shield (propane gas)	3000371
15b	Air shutter Cover (natural gas)	4002346
16a	Air shutter slider (propane gas)	320B293
16b	Air shutter slider (natural gas)	4002345
17	Burner (natural gas)	740K189
	Burner (propane gas)	740K190
18	Injector elbow 82-650 (natural gas)	9730012
	Injector elbow 92-260 (propane gas)	9730007
19	Burner mounts (2)	4001964
20	Front log supports (2)	4001965
21	Pilot assembly (natural gas)	4000062S
	Pilot assembly (propane gas)	4000063S
22	Pilot bracket	720A542
23	Pilot injector no. 35 (natural gas)	4002511
	Pilot injector no. 27 (propane gas)	720A195
24	Hooked olive for pilot injector	720A196
25	Olive nut for pilot pipe	420K385
26	Electrode	720A543
27	Electrode retaining nut	720A200
28	Thermocouple	4000061
29	Pipe—valve to pilot	030A226
30	Olive nut for pilot pipe	220K913
31	Pilot shield	4002203
32	Pilot support bracket	330A904
33	Pilot seal	620B995
34	Access plate	4001680

	Description	Part no.
35	Pipe—valve to main burner	3000247
36	Burner plate	4001966
37	Gaskets—module plate sides (2)	3000399
38	Gaskets—module plate front & back	3000400
39	Switch bracket	4001070
40	Valve mounting bracket	4002885
41	Thermocurrent interruptor	4001037
45a	GV60 Valve assembly (natural gas)	4003095
45b	GV60 Valve assembly (propane gas)	4003108
46	Ignition cable 500 mm	4001039
46a	Ignition cable sleeve	4002244
47	Cable interruptor	4001035
48	Switch with cable	4001036
50	Handset wall holder	9000008
51	Wiring harness	4001187
52	Handset G6R H3T5-ZV (BJ)	4001910
53	Receiver G6R-R3AM-ZV (CP)	4001911
54	Liner panels—complete set	
a	Reflective Glass	618RGL
b	Ceramic fluted black	620FBL
c	Valor red brick	621VRL
d	Ledgestone	622LSL
55	Rear panel	
a	Reflective Glass	4005001
b	Ceramic fluted black	4002109
c	Valor red brick	4002105
d	Ledgestone	4002113
56	Left side panel	
a	Reflective Glass	4005000
a	Infill panel	4005002
b	Ceramic fluted black	4002107
c	Valor red brick	4002103
d	Ledgestone	4002111
57	Right side panel	
a	Reflective Glass	4004999
b	Ceramic fluted black	4002108
c	Valor red brick	4002104
d	Ledgestone	4002112
58	Top panel	
a	Ceramic plain black	4002110
b	Ceramic plain black	4002110
c	Valor red brick	4002106



## Replacement Parts

	Description	Part no.
d	Ledgestone	4002114
59	Traditional Log set complete	534LSK
60	Rear log	4003795
61	Left top log	4003796
62	Right top log	4003797
63	Right center log	4003798
64	Left front log	4003800
65	Right front log	4003801
66	Loose coals pieces	4001843
67	Rock Set Complete	534RSK
68	Rock No. 1	4001821
69	Rock No. 2	4001822
70	Rock No. 3	4001823
71	Rock No. 4	4001824
72	Rock No. 5	4001825
73	Rock No. 6	4001826
74	Rock Base	4001792
75	LH Twig	4001827
76	RH Twig	4001828
77	Front Support—Platform	4001998AH
78	Ceramic Platform	4001997
79	Glass Panel	4001836
80	Hot Glass Warning Plate	4003093
81	Driftwood Kit	534DWK
82	Rear Log	4005815
83	Base Log	4005816
84	RH Cross Log	4005616
85	Front Log	4005817
86	LH Cross Log	4005618
87	Small Beige Beach Pebble (3)	4003087
88	Small Grey Beach Pebble	4003086
89	Brown Beach Pebble	4003082
90	Grey Beach Pebble	4003083
91	Platform	4005329
92	GV60 Repair Valve Kit	4004544
93	Auxiliary battery holder	4006553
94	Battery holder cable 1500 mm	4006552

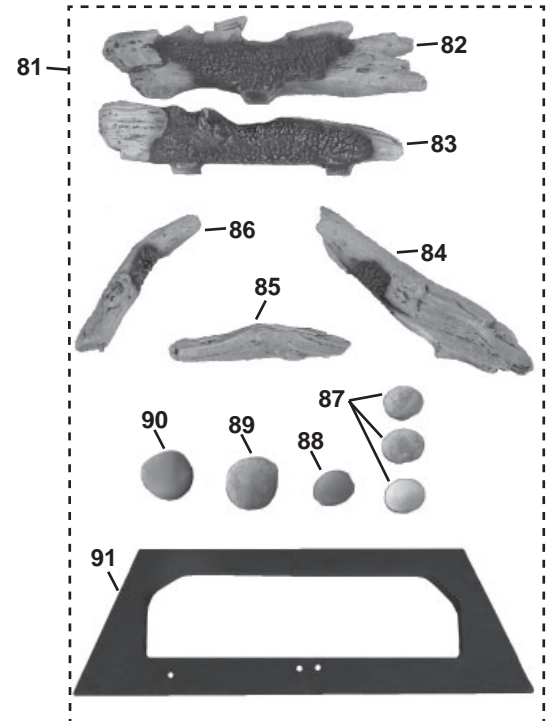

**Replacement Parts**

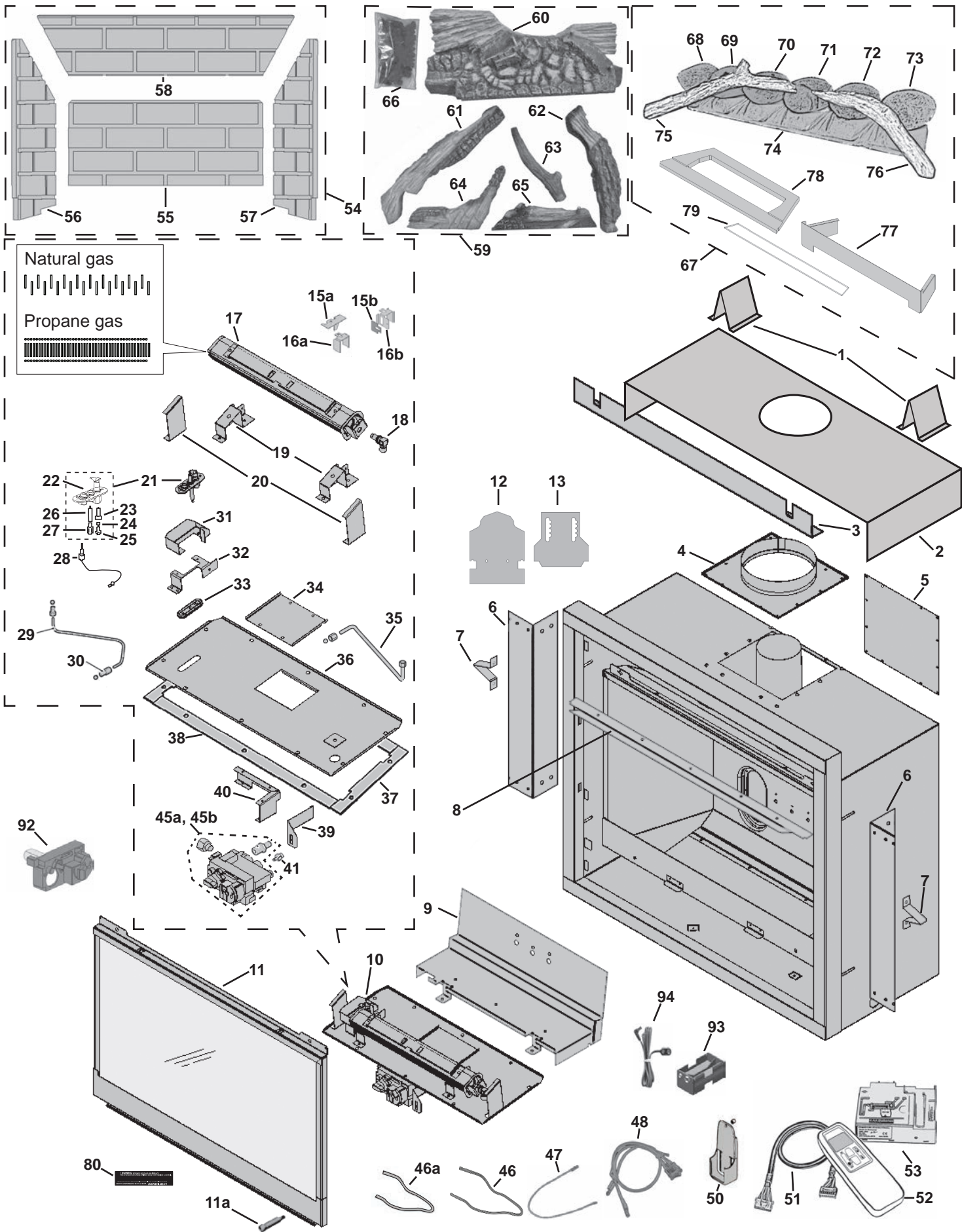



## Thank You ...

For purchasing a Valor by Miles Industries. Your new radiant gas heater is a technical appliance that must be installed by a qualified installer.

*Please fill in the information below. The information provided will be used for customer records only.*

### Fireplace Information

Model Number: 534  JN or  JP /  INSTALLED OUTDOOR

Serial Number:

Date Purchase (yyyy-mm-dd):

Dealer:

### Customer Information

First Name:

Last Name:

### Contact Information

Email:

### Mailing Address

Address:

City:

Province/State:

Postal/Zip Code:

Country:

Cut out page, fill information, and mail to Miles Industries Ltd.

Online Warranty registration at [www.valorfireplaces.com](http://www.valorfireplaces.com)



Tape Shut



Fold here



Postage  
needed

Valor Fireplaces  
190 - 2255 Dollarton Highway  
North Vancouver, BC V7H 3B1  
Canada

**Online Warranty registration at [www.valorfireplaces.com](http://www.valorfireplaces.com)**

*Thank you for choosing a Valor Product*